



Owner's Manual

Table of Contents

1 Introduction	1
1.1 Introduction	1
1.1.1 Introduction	1
2 Manual description	3
2.1 Manual description	3
2.1.1 Manual description	3
3 Picture index	4
3.1 Exterior	4
3.1.1 Exterior	4
3.2 Interior	6
3.2.1 Interior	6
4 Safety instructions	10
4.1 Instructions for safe use	10
4.1.1 Before driving	10
4.1.2 Safe driving	10
4.1.3 Seat belt	13
4.1.4 Airbag	18
4.1.5 High voltage system	30
4.1.6 Precautions for waste gas	32
4.2 Child safety	33
4.2.1 Child safety information	33
4.2.2 Child safety seat	35
4.2.3 Installation of child safety seat	40
4.2.4 Child safety lock	44
4.3 Range extender system	46
4.3.1 Range extending system feature	46
4.3.2 Precautions for range extending	48
4.4 Anti-theft system	49
4.4.1 Anti-theft system	49
5 Information display	50
5.1 Instrument and central control system	50
5.1.1 Instrument screen	50
5.1.2 Central control screen	55

6 Operation	58
6.1 Key information	58
6.1.1 Key	58
6.1.2 Remote-control key	59
6.1.3 Keyless entry and start system	62
6.2 Opening, closing and locking door	66
6.2.1 Door	66
6.2.2 Trunk door	75
6.3 Seat adjustment	85
6.3.1 Front seats	85
6.3.2 Second row seat	91
6.3.3 Third row seat	104
6.3.4 Headrest	108
6.4 Adjustment of steering wheel and rearview mirror	112
6.4.1 Steering wheel	112
6.4.2 Interior rearview mirror	117
6.4.3 Exterior rearview mirror	120
6.5 Memory function	125
6.5.1 Driver memory function	125
6.5.2 Driver welcome seat	126
6.6 Window and sunshade	127
6.6.1 Window	127
6.6.2 Sunshade	132
6.7 A/C system	136
6.7.1 Front A/C system	136
6.7.2 Rear AC system	140
6.7.3 Steering wheel heating/seat heating and ventilation	145
6.8 Vehicle interior illumination light	148
6.8.1 Interior reading lamp control	148
6.8.2 Vanity lamp	150
6.8.3 Ambient light	151
6.8.4 Welcome light illumination	151
6.9 Storage device	152
6.9.1 Glove box	152
6.9.2 Storage box	153

6.9.3	Cup holder	158
6.9.4	Seat map pocket	161
6.9.5	Trunk equipment	162
6.9.6	Luggage rack	166
6.9.7	Fridge	168
6.10	Other onboard equipment	172
6.10.1	Sunshade	172
6.10.2	Vanity mirror	172
6.10.3	12 V power socket	173
6.10.4	220 V power socket	174
6.10.5	Wireless charging	176
6.10.6	USB/Type-C/Type-A interface	178
6.10.7	Driving recorder	183
6.10.8	Microphone	184
6.10.9	Assist grip	185
6.10.10	Coat hook	186
6.10.11	Magnet track lamp	187

7 Driving 188

7.1	Before driving	188
7.1.1	Driving vehicle	188
7.1.2	Cargo and luggage	190
7.1.3	Traction mode	191
7.2	Driving specification	197
7.2.1	Power mode switching	197
7.2.2	Gearshift mechanism	198
7.2.3	Turn signal light control	200
7.2.4	Low-speed pedestrian warning sound	201
7.2.5	Special road condition	201
7.2.6	Tire pressure monitoring system (TPMS)	201
7.2.7	Electronically controlled adjustable suspension	202
7.2.8	Speed-sensitive variable electronic power steering	208
7.3	Driving essentials	209
7.3.1	Driving essentials for extended range vehicles	209
7.3.2	Winter driving essentials	212
7.3.3	Precautions for extended range vehicles	213

7.4	ROX mode	214
7.4.1	ROX mode	214
7.5	Operation of light and wiper	218
7.5.1	Exterior light switch	218
7.5.2	Low beam height adjustment	219
7.5.3	Automatic high beam light	219
7.5.4	Automatic low beam light	219
7.5.5	Brake lamp	220
7.5.6	Reverse lamp	220
7.5.7	Fog light switch	220
7.5.8	Windshield wiper and washer	220
7.5.9	Rear window wiper and washer	224
7.6	Combined driving assist system	225
7.6.1	ACC	225
7.6.2	Cruise control	232
7.6.3	Lane departure assist	236
7.6.4	LCC	238
7.6.5	Commanded lane change	246
7.6.6	RCW	250
7.6.7	Shadow area detection aid	252
7.6.8	CTA	255
7.6.9	DOW	257
7.6.10	Assisted parking	259
7.6.11	Assisted remote parking	262
7.6.12	Around view monitoring	265
7.6.13	Emergency brake assist	268
7.6.14	ELK	271
7.6.15	Rearward emergency brake assist	273
7.6.16	FCW	275
7.7	Brake system	278
7.7.1	Electronic handbrake (EPB)	278
7.7.2	Body electronic stability program (ESP)	280
7.7.3	Anti-lock brake system (ABS)	280
7.7.4	Electronic brake-force distribution (EBD)	281
7.7.5	Traction control system (TCS)	281

7.7.6	Hydraulic brake assist (HBA)	281
7.7.7	Roll motion intervention (RMI)	282
7.7.8	Cornering stability control (CSC)	282
7.7.9	Dynamic parking brake (CDP)	283
7.7.10	Hill descent control (HDC)	284
7.7.11	Hill start assist (HHC)	284
7.7.12	Coordinated regenerative braking system (CRBS)	285
7.8	Fuel oil and charging	286
7.8.1	Refuel	286
7.8.2	Charging (Configuration 1)	291
7.8.3	Charging (Configuration 2)	301
7.8.4	External discharge (Configuration 1)	312
7.8.5	External discharge (Configuration 2)	317
7.8.6	Power battery	323

8 Maintenance and repair 325

8.1	Maintenance and repair	325
8.1.1	New car run-in	325
8.1.2	Vehicle cleaning	325
8.1.3	Vehicle maintenance	326
8.1.4	Anti-corrosion	330
8.2	Regular maintenance	331
8.2.1	Regular maintenance	331
8.3	Self-maintenance	332
8.3.1	Hood	332
8.3.2	Engine room	334
8.3.3	Battery	336
8.3.4	Tire	338
8.3.5	Tire pressure	341
8.3.6	Wheel	342
8.3.7	A/C filter	342
8.3.8	Windshield wiper	343
8.3.9	Remote-control key battery	344
8.3.10	Check and replace the fuse	346
8.4	Vehicle long-term parking	347
8.4.1	Vehicle long-term parking	347

9 In case of fault	349
9.1 Measures to be taken in case of emergency	349
9.1.1 On-board tools	349
9.1.2 Hazard warning lamp.....	351
9.1.3 Reflective vest	353
9.1.4 Warning sign	354
9.1.5 Vehicle needs towing	354
9.1.6 Inflation pump	365
9.1.7 Tire changing operation.....	366
9.1.8 Emergency start-up	372
9.1.9 Battery level depleted	374
9.1.10 Vehicle overheating	374
9.1.11 In case of vehicle getting stuck	375
9.1.12 Emergency call.....	376
9.2 Accident rescue	378
9.2.1 Appearance identification information	378
9.2.2 Rescue protection device	379
9.2.3 Emergency cut-off high voltage system	380
9.2.4 Vehicle fire rescue	382
9.2.5 Vehicle wading rescue	382
9.2.6 Battery leak rescue.....	383
9.2.7 Vehicle cutting area.....	383
9.3 Vehicle remote diagnosis	386
9.3.1 Vehicle remote diagnosis system.....	386
10 Vehicle specification	387
10.1 Specification	387
10.1.1 Maintenance data (fuel, oil, etc.).....	387
10.2 Main dimension parameters of vehicle	388
10.2.1 Front and back of vehicle	388
10.2.2 Vehicle side	390
10.3 Vehicle technical performance parameters	392
10.3.1 Vehicle mass parameters	392
10.3.2 Power parameter.....	392
10.3.3 Energy economy parameter	392
10.3.4 Vehicle model	392

10.3.5	Drive type	393
10.4	Assembly technical parameters	394
10.4.1	Range extender (engine) specifications and parameter	394
10.4.2	Tire and hub parameters	394
10.4.3	Four-wheel alignment	395
10.4.4	Drive motor performance parameters	396
10.4.5	Power battery parameter	396
10.4.6	Brake system parameters	397
10.5	Vehicle identification information	398
10.5.1	Vehicle identification number (VIN)	398
10.5.2	Range extender (engine) ID code	399
10.5.3	Drive motor identification code	400
10.5.4	Microwave window	402
10.5.5	Ex-work nameplate	403
10.5.6	Diagnostic interface	404
10.5.7	Warning and indication label	405

11 Abbreviations and terminology 406

11.1	Abbreviations and terminology	406
11.1.1	Abbreviations and terminology	406

1 Introduction

1.1 Introduction

1.1.1 Introduction

Dear ROX owner,

Thank you for choosing ROX ADAMAS.

Please read this manual carefully before driving your ROX ADAMAS. Through this manual, you will fully understand the technical features and operation information of the vehicle. ROX reserves the right to change the contents of this manual at all times. Your vehicle may vary depending on the version or manufacture date.

This manual explains the use of the vehicle in the form of text and schematic diagram. In general, both are consistent for the use of the vehicle. If you have any inconsistent in understanding, you can operate following the schematic diagram. Nevertheless, the relevant information displayed may vary depending on vehicle configuration, optional parts, software version and other conditions. The schematic diagram is for reference only. In case of any discrepancy between the diagram and the actual product, the specific information shall be subject to the actual vehicle model.

Please strictly follow the warning information used in this manual, which will help you use your vehicle more safely. Incorrect operation of the vehicle may cause personal injury to you or others, or cause damage to the vehicle or property loss. ROX shall not be held responsible for it therefrom.

We wish you a safe and enjoyable drive. ROX

I. Accessory, part and modification

For parts to be replaced, it is strongly recommended to use the original parts or approved accessories of ROX.

For any non-original parts or accessories not approved by ROX, whether for replacement or installation, ROX neither bears any liability nor provides any guarantee for it. Moreover, vehicle damage and performance problems caused by the use of non-original or non-approved ROX parts are not covered by the warranty.

Improper modification of the vehicle or installation of unapproved accessories may affect the maneuverability, safety or durability of the vehicle, and may also violate laws and regulations. In addition, vehicle damage or performance problems caused by modification are not covered by the warranty.

II. When driving your vehicle

Be sure to abide by traffic regulations and road speed limits, and always keep in mind to drive safely.

Do not drive a vehicle when your reaction ability is reduced (drugs, alcohol and fatigue, for example, can impair your reaction ability).

Please drive carefully, and pay attention to the trends of other road traffic participants at any time, so as to respond in time to avoid accidents.

III. Scrapping

The airbags and seat belt pretensioner in the vehicle contain explosive chemicals. Scrapping your vehicle without removing the airbags and seat belt pretensioner may lead to an accident. Therefore, before scrapping your vehicle, be sure to have it dismantled and scrapped by a professional service shop or contact ROX Service Center.

IV. Environment protection

Improper handling of used parts, waste engine oil and power batteries can lead to environmental pollution. Therefore, please consult ROX Service Center before scrapping your vehicle. If your vehicle requires exhaust gas testing, please contact ROX Service Center.

V. Electromagnetic protection

The millimeter wave radar equipped with the vehicle works in the frequency range of 76-79 GHz, meeting the radio frequency technical requirements of the automobile radar. To protect the radio astronomy business working in the same frequency band, vehicles are not allowed to enter the relevant restricted areas.

VI. Precautions for combined driving assist function

The combined driving assist system of ROX ADAMAS senses the surrounding environment through sensors such as cameras, millimeter-wave radar and LIDAR, and calculates and analyzes environmental information, so as to realize early warning of certain dangerous scenarios and vehicle control. Using combined driving assist function in suitable scenarios can relieve driving fatigue and improve driving safety. However, the combined driving assist system has limitations. For your driving safety, please be sure to read the following carefully before using the combined driving assist system:

Cruise control: Once the cruise control function is activated, the system will automatically control the vehicle to the set cruising speed. At this time, the system will not accelerate or decelerate according to the traffic participants ahead, but will only maintain the cruising speed. The driver needs to be ready to control the vehicle at any time.

In addition to the above functions, ROX ADAMAS also has other combined driving assist functions. For more information on combined driving assist function, please refer to the electronic manual.

2 Manual description

2.1 Manual description

2.1.1 Manual description

S/N	Instruction
1	Introduce the warnings. Failure to follow may lead to serious injury or even death.
2	Introduce tips to better understand the vehicle.
3	Introduce precautions. Failure to follow may lead to damage or malfunction of the vehicle or equipment.
4	Introduce environmental protection issues. Failure to follow may cause environmental pollution.



3.1 Exterior

3.1.1 Exterior

S/N	Name	S/N	Name
1	Hood	2	Wiper
3	Side view camera	4	Outside door handle
5	Fuel filling port		

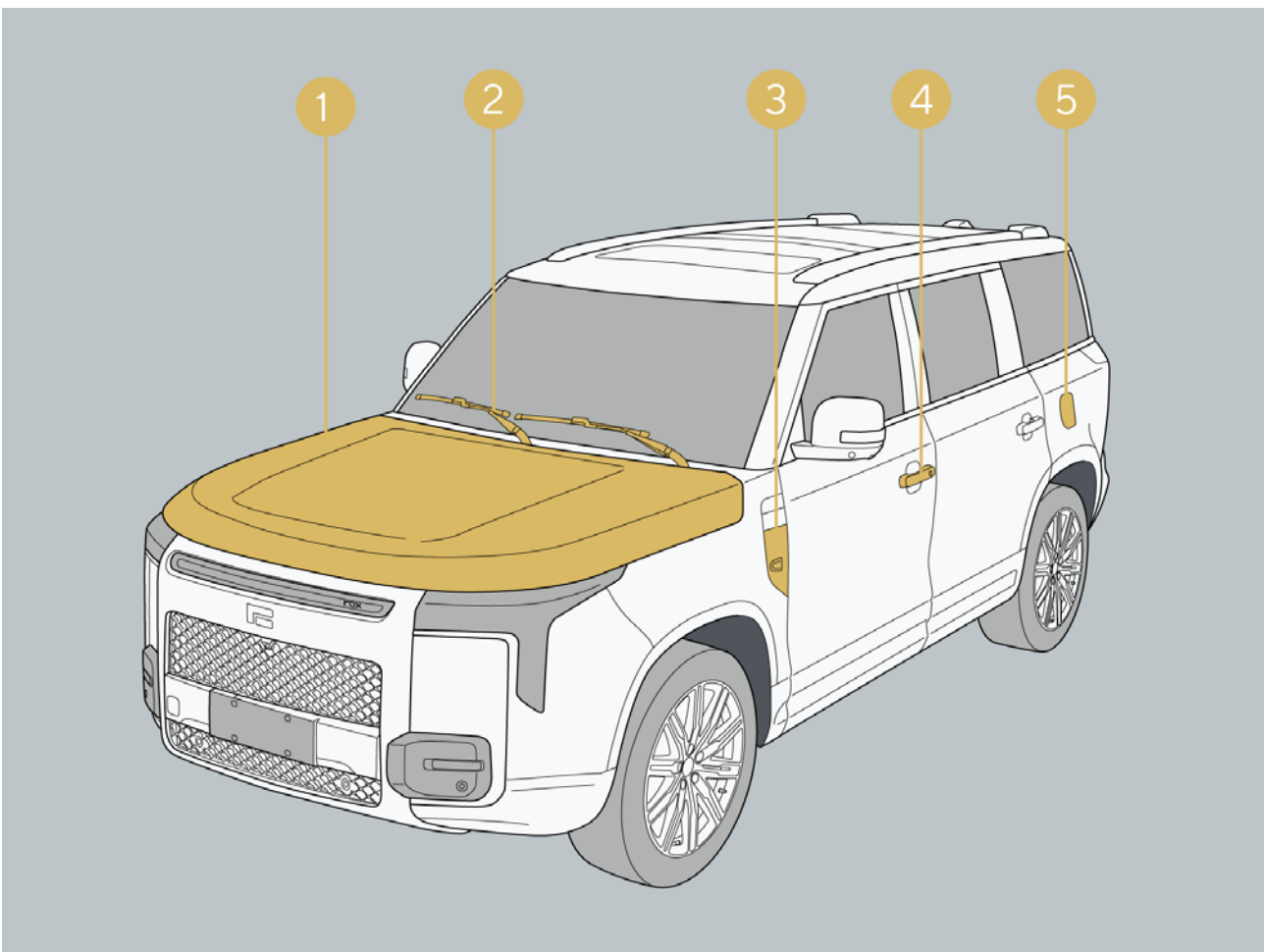

3 Picture index

S/N	Name	S/N	Name
1	Stream media rearview camera	2	High-position brake lamp
3	Rear wiper	4	Tailgate handle
5	Rear towing hook cover	6	Charging port lid

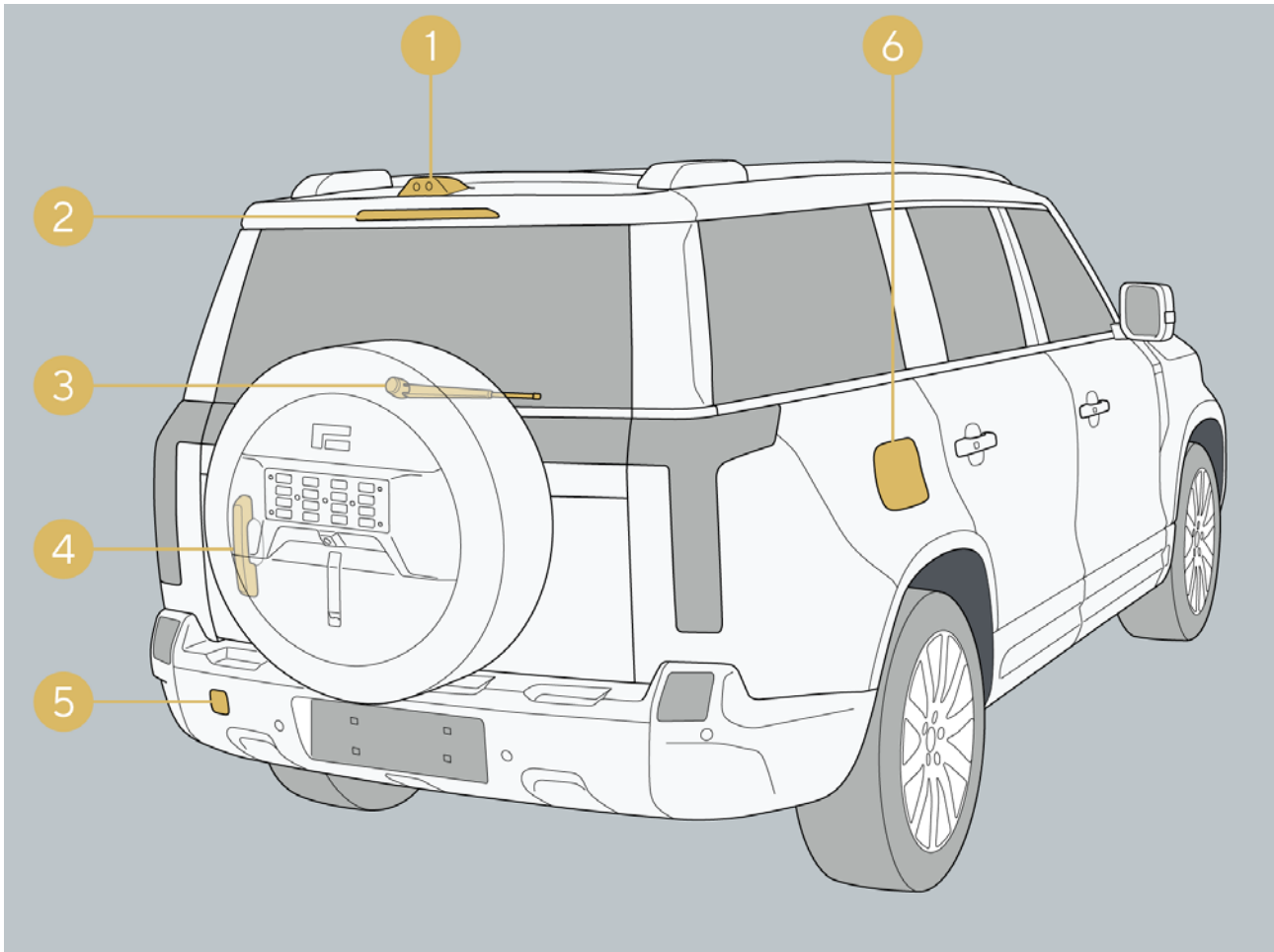

3.2 Interior

3.2.1 Interior

I. Common components in the front row

S/N	Name	S/N	Name
1	Glasses box	2	Sunshade
3	Interior rearview mirror	4	Assist grip
5	Glove box	6	Cup holder
7	Shift handle	8	Brake pedal
9	Engine hood unlock handle	10	Window button

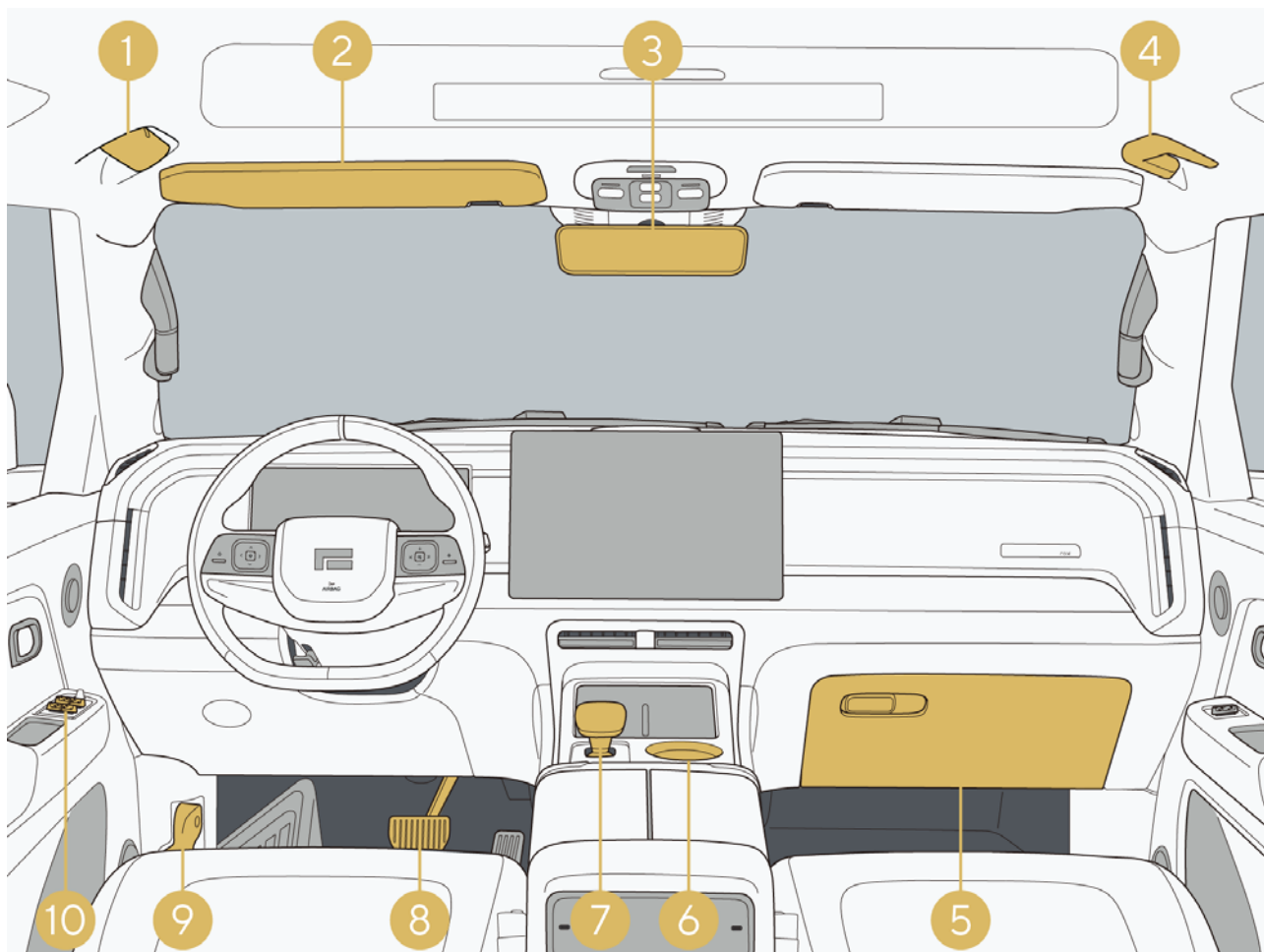

3 Picture index

S/N	Name	S/N	Name
11	Inside door handle	12	Steering wheel button (left)
13	Instrument screen	14	Steering wheel button (right)
15	Central control screen	16	Assist grip
17	Hazard warning lamp key	18	Wireless charging locker
19	Accelerator pedal	20	Horn

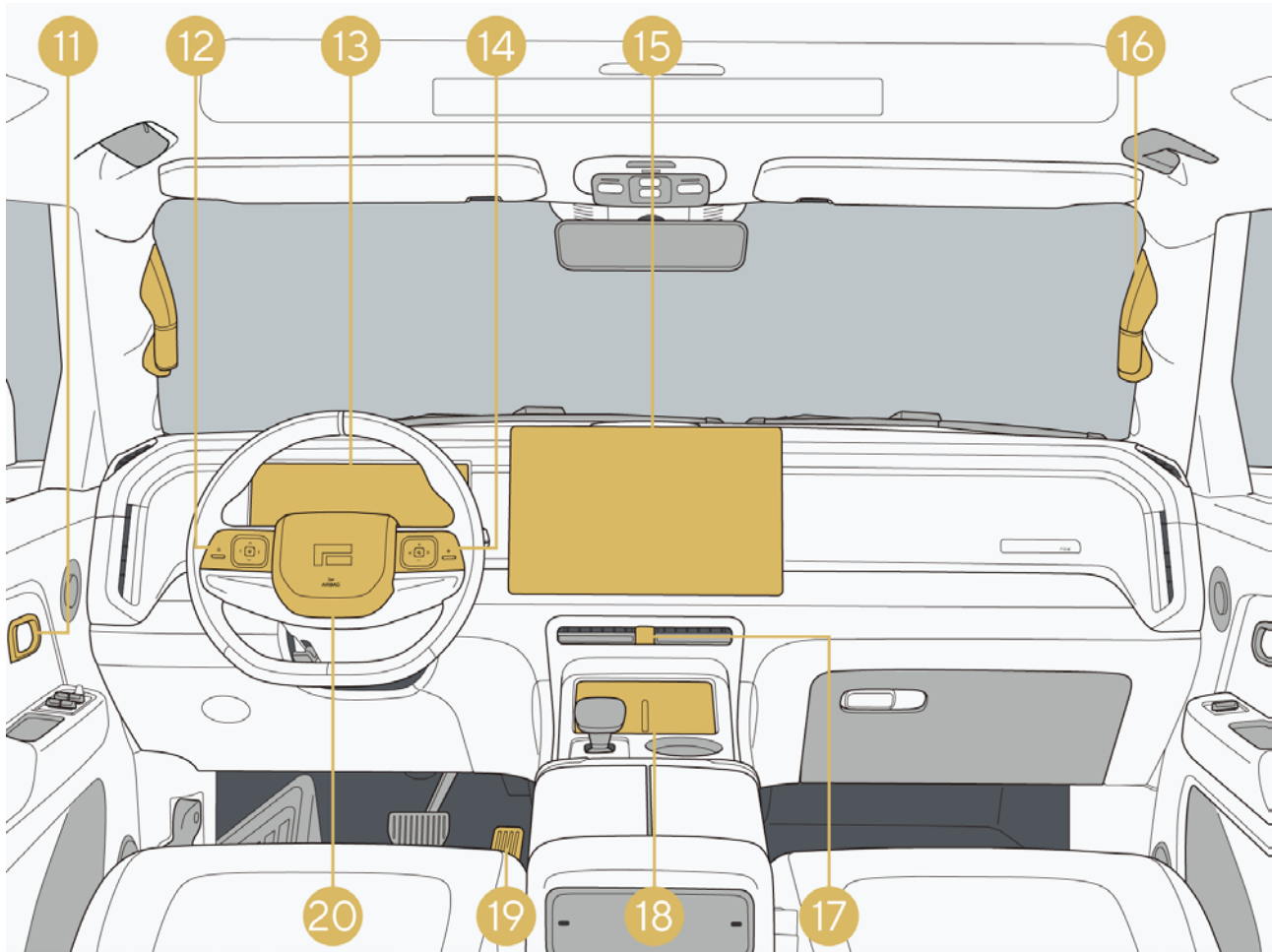

II. Common components in the rear row

S/N	Name	S/N	Name
1	Assist grip	2	Rear screen
3	Window button	4	Seat map pocket
5	Boss button	6	Coolbox control panel
7	Rear row A/C control panel	8	Door inside handle

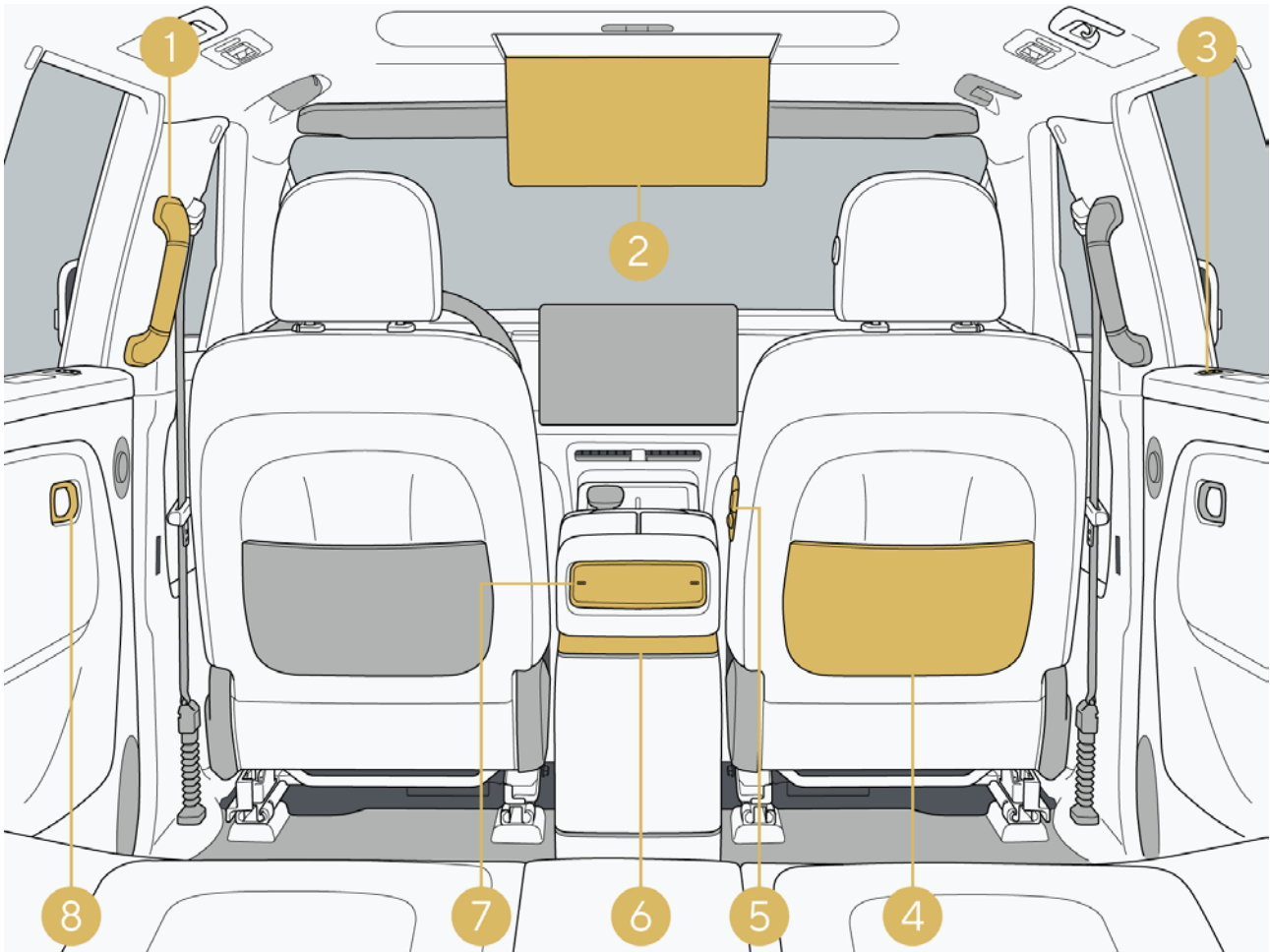

3 Picture index

III. Common components for the third row

S/N	Name	S/N	Name
1	Assist grip	2	Air conditioning outlet
3	Type-C/ seat adjustment button	4	Cup holder

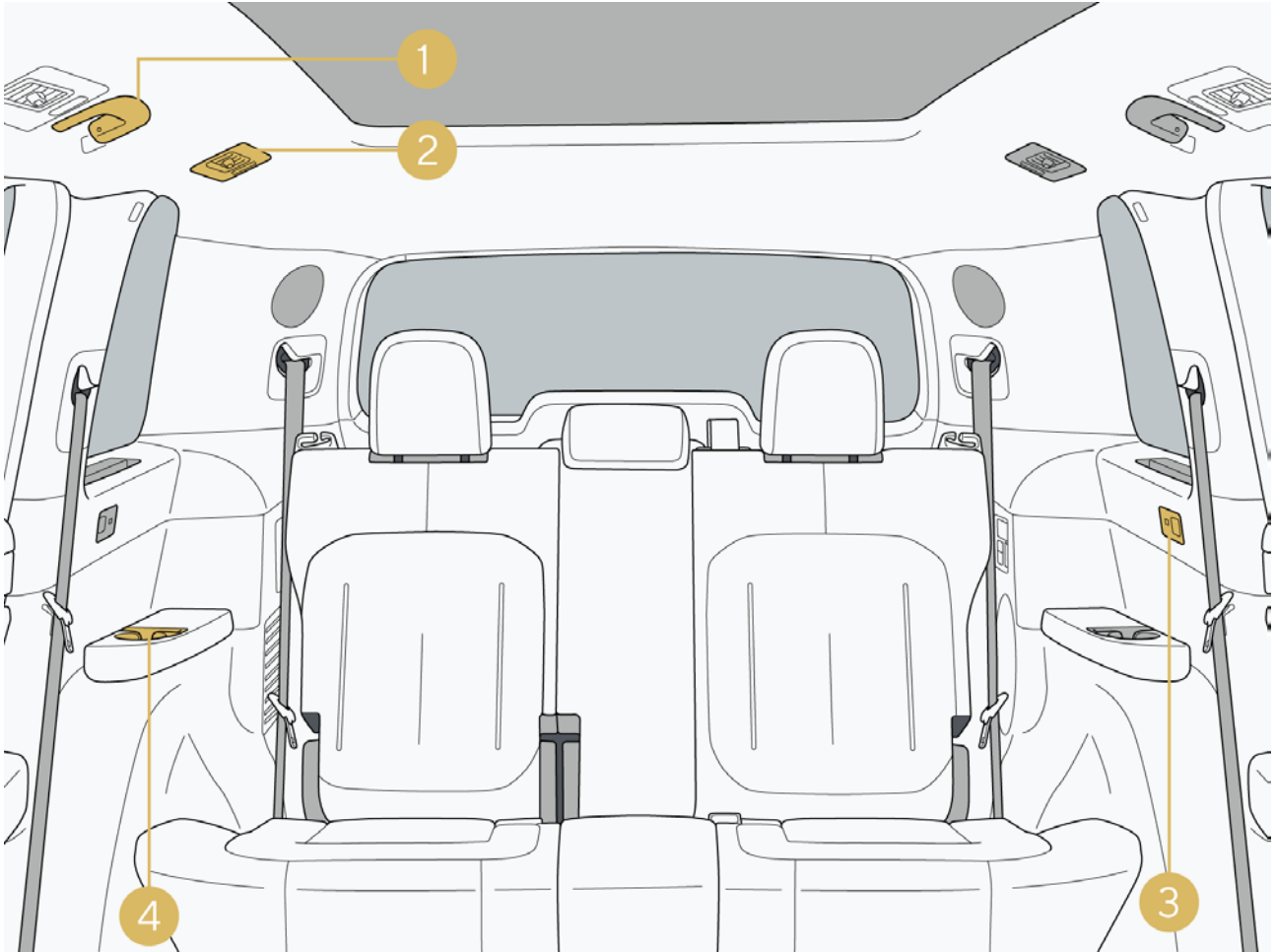

4.1 Instructions for safe use

4.1.1 Before driving

For the safety and comfort of you and your passengers, the following checks are recommended before each drive:

- Make sure that all lamps are functioning properly.
- Make sure that the fuel and electricity are sufficient.
- Make sure that there are no obstacles around the vehicle.
- Make sure that all windows are clear and have a good view.
- Make sure that there are no obstacles within the brake pedal and accelerator pedal area, without affecting operation.
- Make sure that the tire pressure is normal.

Warning

- Do not drive in high heels or slippers.
- Do not drive your vehicle after drinking alcohol.

4.1.2 Safe driving

I. Adjust your sitting position

- Adjust the seat position to ensure that all pedals can be easily operated by your feet while driving. The distance between the steering wheel and your chest shall not be less than 250 mm.
- Adjust the seat backrest to ensure that the driver's back fits perfectly with the seat backrest.
- Adjust the seat headrest to make the ears flush with the center of the headrest, ensuring that the entire head is well supported.
- Pull out the seat belt and pass it from the front of the body, make the upper part of the seat belt close to the shoulder, and the lower part of the seat belt close to the hip, and then insert the seat belt lock tongue into the seat belt socket of the corresponding seat.

4 Safety instructions

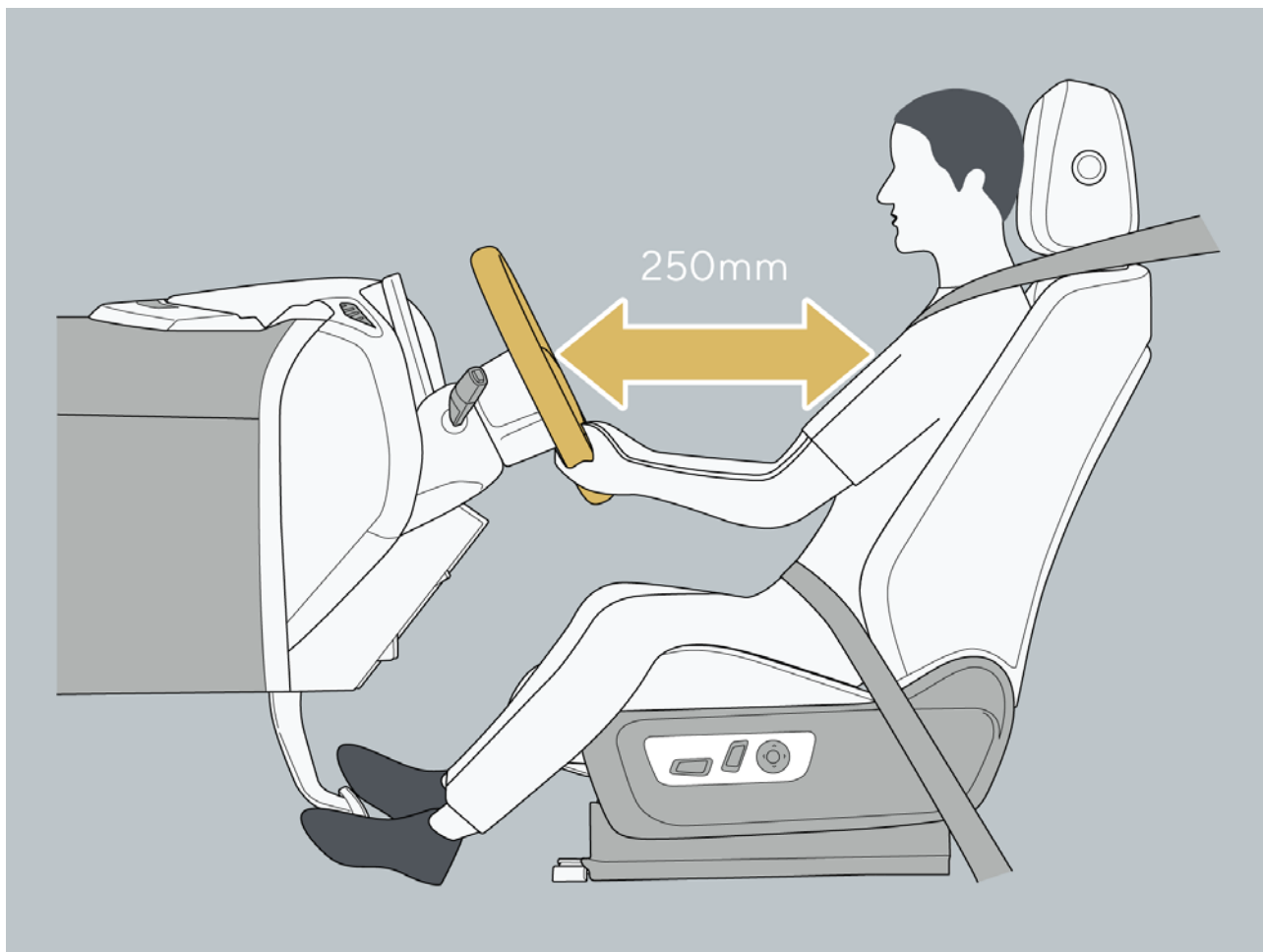

II. How to use the seat belt

Before driving the vehicle, all driver and passengers of the vehicle should fasten their seat belts.

If there are children in the car, appropriate child safety seats should be used according to the age and size of the child.

III. Adjustment of rearview mirror

Correctly adjusting the interior and exterior rearview mirrors before driving the vehicle can reduce blind spots and improve driving safety.

VI. Prohibited items

- To ensure the safety of the vehicle and drivers and passengers, please do not store flammable and explosive items such as lamps, hairspray, perfume, alcohol, etc. in the vehicle. In summer or other high-temperature environments, flammable and explosive items in the car may cause a fire.
- Do not place items on the dashboard. Items placed on the dashboard will block the driver's view. Moreover, in case of a vehicle collision, the airbag will pop up, and the items placed on the dashboard may pop up following the airbag, causing harm to the occupants in the car.
- Do not install ornaments on the windshield or window glass. Ornaments installed on the windshield will hinder the driver's vision. Moreover, the ornaments may shake and break the glass when the vehicle is driving on bumpy roads.

4 Safety instructions

- Do not place items in the driver's foot space. During driving, items may move forward to the pedal area due to inertia, affecting the pedal movement and causing safety accidents.

Warning

- Do not adjust the driver's seat while driving. Avoid suddenly tilting your body that could cause the vehicle to lose control.
- Do not adjust the exterior mirrors during driving to avoid blind spots, causing accidents or resulting in serious personal injury in accidents.
- Do not place anything under the driver's seat that may affect operation.
- Do not drive while fatigued or under the influence of alcohol.
- Please drive your vehicle strictly in accordance with the traffic rules.

4 Safety instructions

4.1.3 Seat belt

I. Use seat belt correctly

1. Maintain a correct sitting position.
2. Pull the seat belt, and place the shoulder seat belt between your neck and shoulders.
3. Keep the waist seat belt as low as possible across your hips.
4. Do not twist seat belts.



II. Use a seat belt

When using the seat belt, slowly pull the seat belt out to an appropriate position, insert the seat belt tongue 1 into the buckle 2, until you hear a "click" sound. Then pull the seat belt to ensure that it is locked. When releasing the seat belt, press the red unlock button 3 to unlock the seat belt, and slowly retract the seat belt after unlocking.

Warning

- Do not use one seat belt by multiple people to avoid failure to protect you in the event of an accident.

4 Safety instructions

- Failure to wear seat belts or incorrect use of seat belts may result in casualties in the event of an accident.
- Do not drive the vehicle when the seat belt is severely worn and distorted. Be sure to replace the seat belt in time to avoid failure to protect you in the event of an accident.

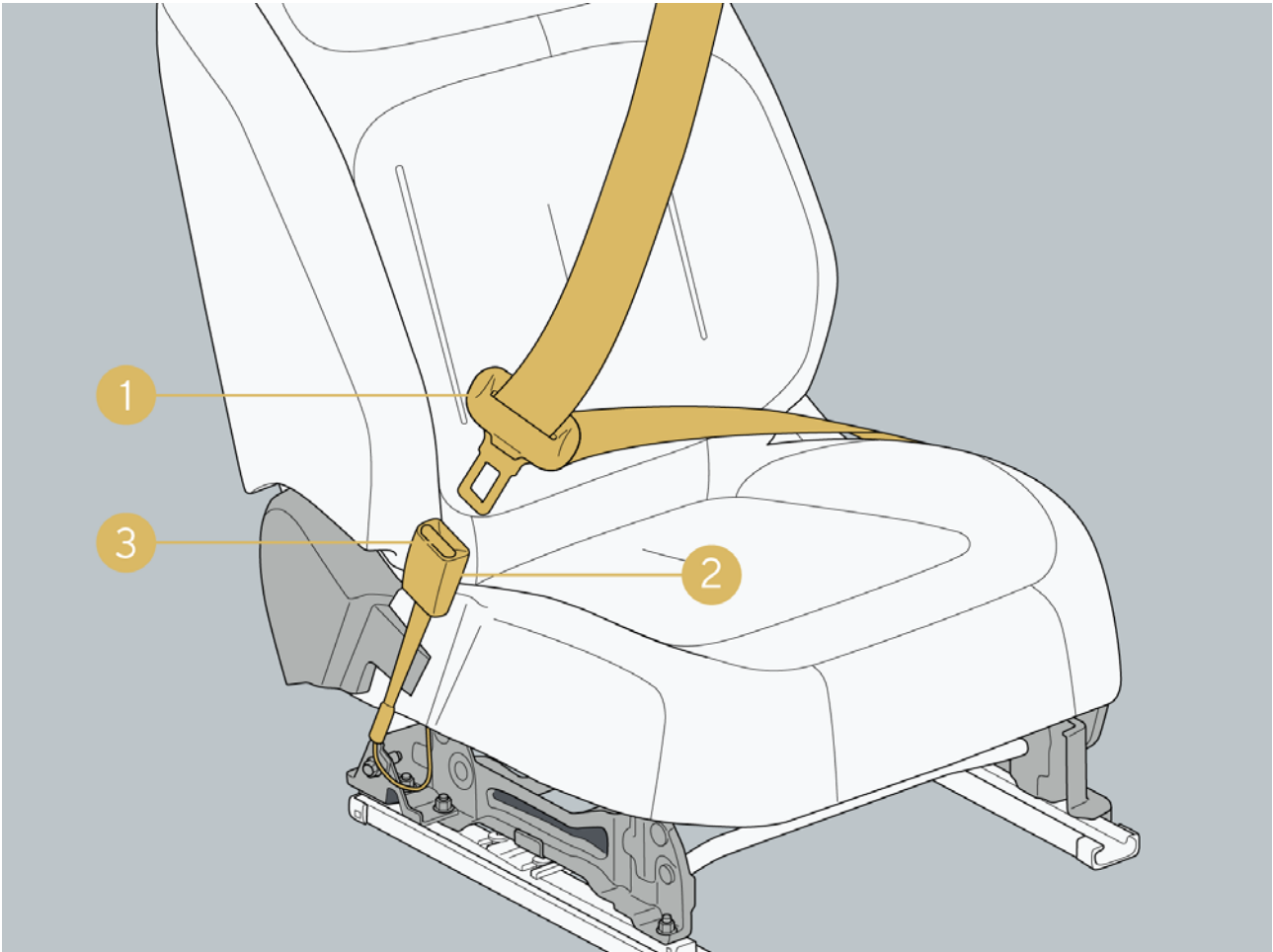

I. Use seat belt correctly during pregnancy

I. The seat belt should be always be worn and used correctly during pregnancy.

Stretch the seat belt diagonally first, then put the shoulder seat belt through the middle of the shoulder and the center of the chest. Put the waist seat belt across the hip below the abdomen and lock it correctly. During using the seat belt, avoid touching the abdomen.

Warning

- As pregnancy progresses, you should adjust your seat and steering wheel to better maintain control of the vehicle (which means you must be able to easily operate the pedals and steering wheel).
- When pregnant women are in a vehicle, they should try to sit in the second row to avoid secondary injuries to the abdomen caused by the airbag device in case of an accident.

4 Safety instructions

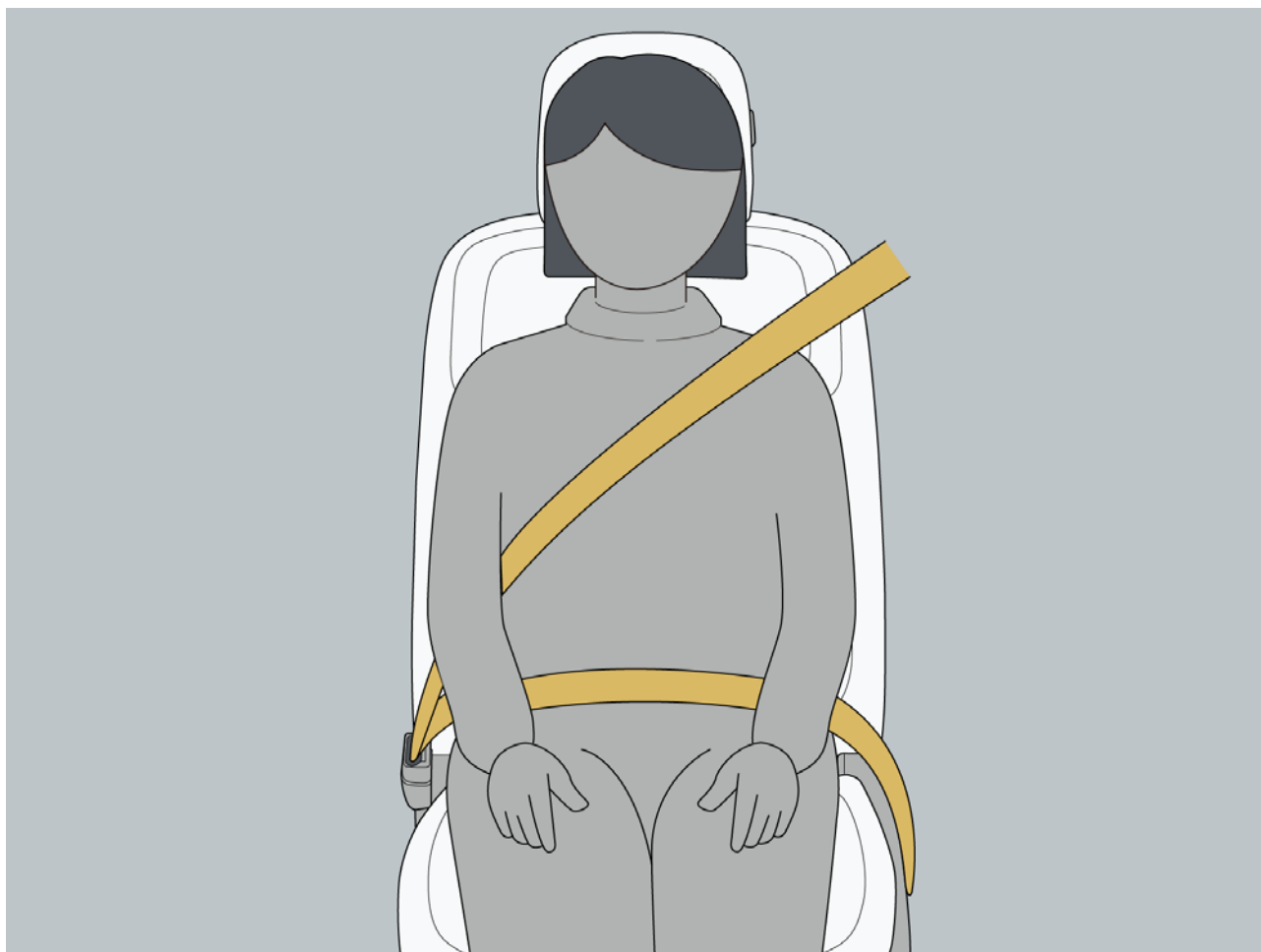

IV. Seat belt height adjustment

When adjusting downward, press and hold the adjustment button, adjust downward to an appropriate position, release the adjustment button, and move downward to ensure the lock is in place. When adjusting upward, there is no need to press and hold the adjustment button, and the seat belt can be directly adjusted to the appropriate position.

Hint

- Only front row belt height can be adjustable.

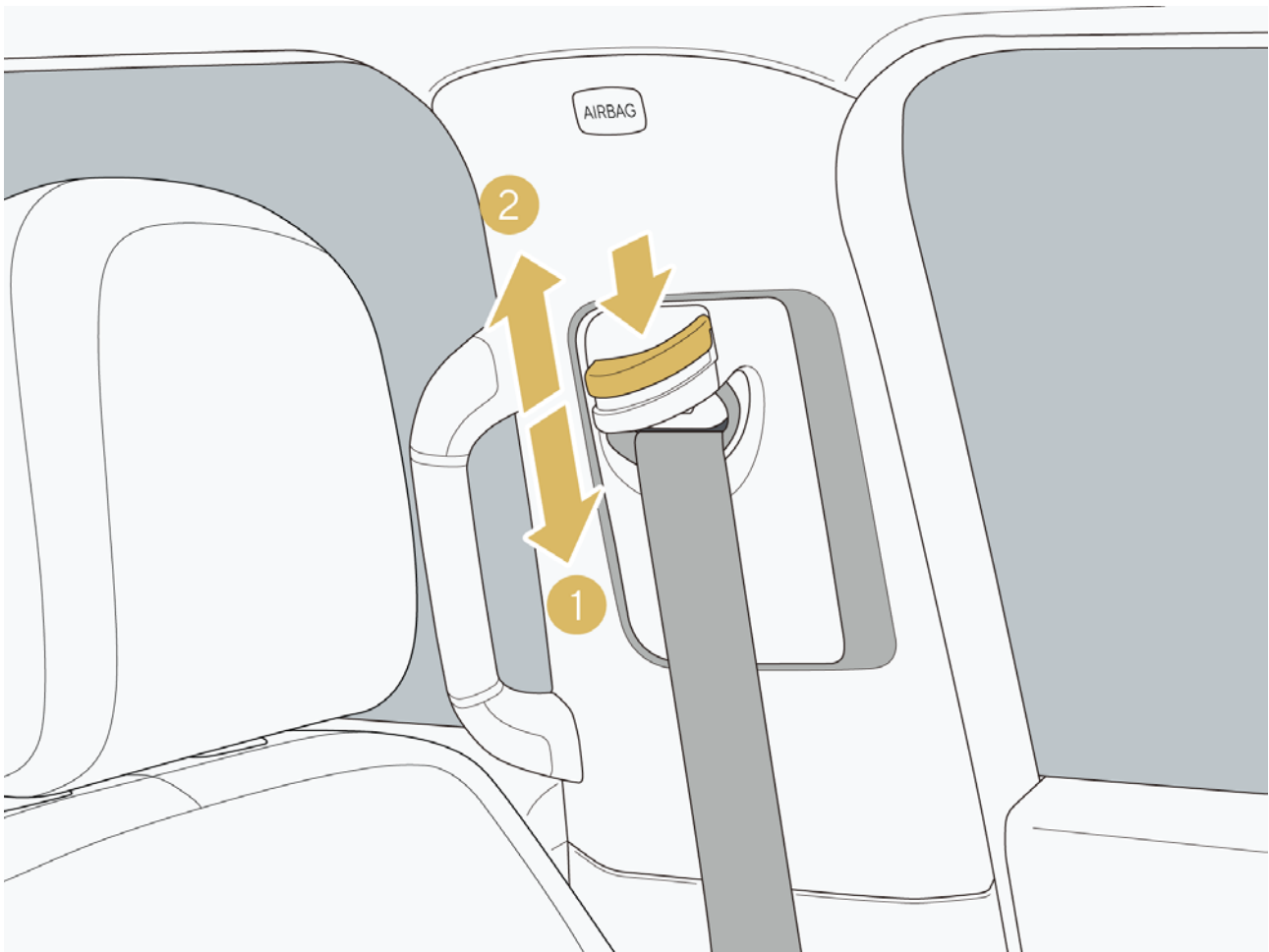

V. Reminder for not wearing seat belts

The front and second rows of seats are equipped with occupant detection devices. If a driver or passenger is not wearing seat belts after the vehicle is started, a safety belt warning tell-tale will illuminate on the instrument panel.

When the vehicle has been driving for 1 min or over 500m, if the driver or the front occupant is not wearing a seat belt, the instrument screen will sound an alarm and the warning lamp that the seat belt is not wearing will flash. After 60s, if it is detected that the occupant in the front row is still not wearing seat belt, the alarm will continue to sound and the warning lamp that the seat belts are not wearing will flash. If only the occupant in the second row is not wearing seat belt, the alarm will stop after 60s. For your and occupants' safety, keep the seat belt fastened during your ride.

Hint

- If there is still an alarm reminder after the seat belt is fastened, it indicates that the seat belt device is faulty or invalid. Please contact ROX Service Center for replacement or maintenance.
- Before driving, please do not place heavy objects on the seat to avoid false alarm of the system.

4 Safety instructions

VI. Seat belt tensioner

Both the front and second row seat belts are equipped with tensioning devices. In the event of a serious collision, the tensioner will operate simultaneously the airbag. The tensioner automatically tightens the seat belt to reduce the forward lean of the driver and passenger.

Warning

- When the seat belt tensioner detonates, it will release a small amount of harmless smoke and make a sound.
- Do not insert anything other than the seat belt tongue to prevent the seat belt from alarming.

4 Safety instructions

4.1.4 Airbag

ROX ADAMAS is equipped with 8 airbags to protect drivers and passengers.

The airbag can be quickly deployed in the event of a serious accident to protect the occupant's head and chest and reduce the degree of serious injury. However, the airbag cannot avoid injuries to the occupant's limbs and body surface. Therefore, the airbag must be used together with the seat belt to play the most protective role.

There is the word "AIRBAG" at the airbag location to remind you that there is an airbag.

1. Side air curtain: Helps protect the head of the occupant in the outer seat.
2. Front airbags: Helps protect the head and chest of the driver and front occupant from hitting by the part in the car in the event of a collision.
3. Seat side airbags: Helps protect the torso area of the occupant in the front seat.

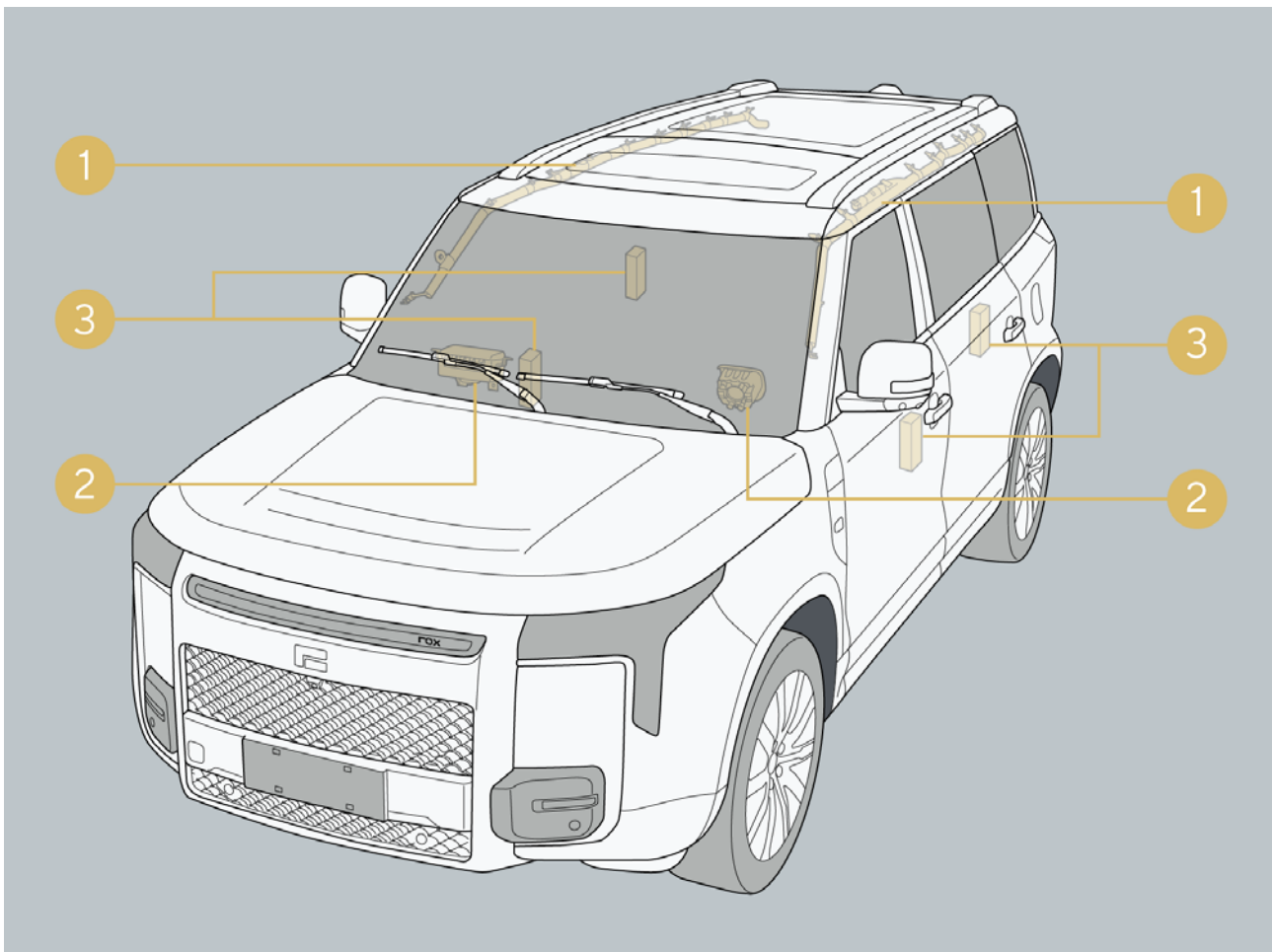

4 Safety instructions

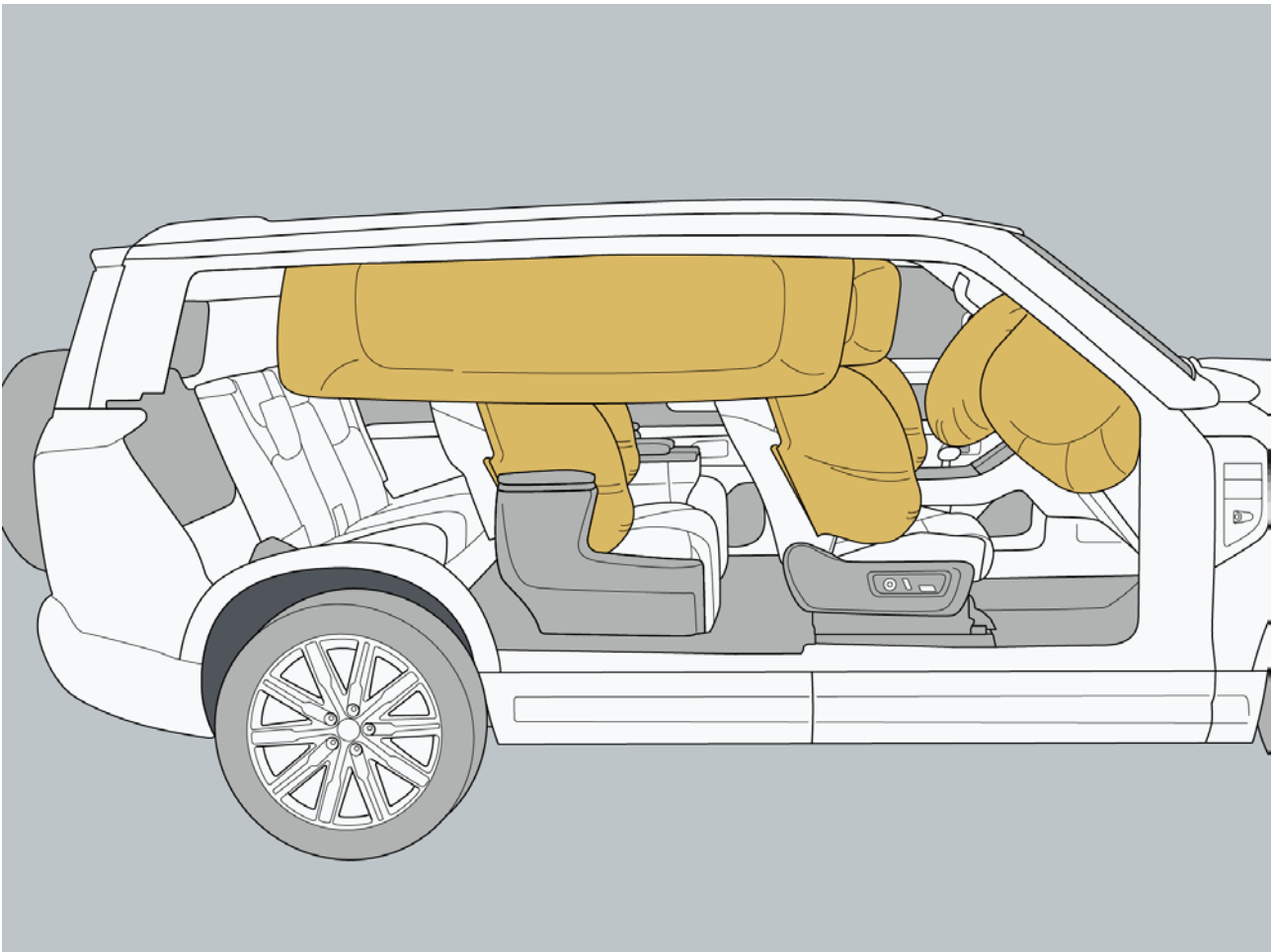

I. Deployment conditions of front airbags

When the collision of the vehicle reaches a certain degree of severity or exceeds the set critical value, the front airbag will be deployed.

II. Airbag deployment

When the airbag is deployed, the following will occur:

- When the airbag is deployed, it may cause the driver and passengers to be bruised or scalded.
- When the airbag is deployed, it can generate smoke and dust.
- After the airbag is deployed, the airbag and seat parts will become hot.
- Windshields may be broken.

III. Deployment conditions of side air curtain and side air bag

- When the collision reaches a certain degree of intensity or exceeds the set critical value, the side air curtain and side air bag will be deployed.
- Side airbags and side air curtains can also be deployed in the event of a serious head-on collision or rollover.

4 Safety instructions

IV. Possible deployment of airbags except for collisions

If the bottom of the vehicle suffers a serious collision or the vehicle quickly drives through a deep pit, etc., the front airbag, side airbag and side air curtain may also be deployed, such as:

- Hitting the hard roadbed.
- Falling into a deep ditch.
- Hard landing of wheels or falling of the vehicle.

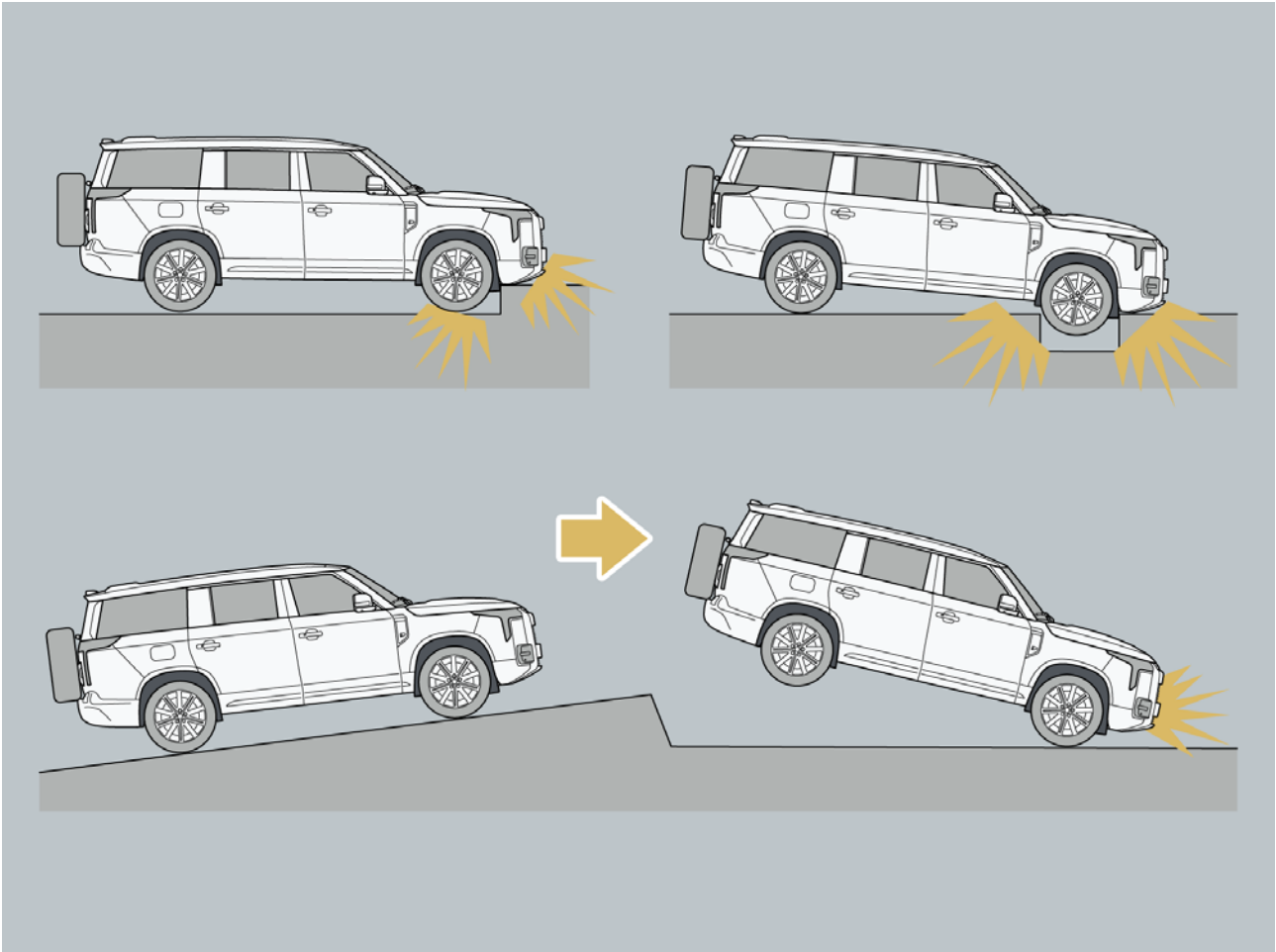

4 Safety instructions

V. Impossible deployment of front airbags

When the vehicle suffers a low-speed head-on collision, side collision, rear collision, or rollover, the front airbag generally will not be deployed, such as:

1. Side collision.

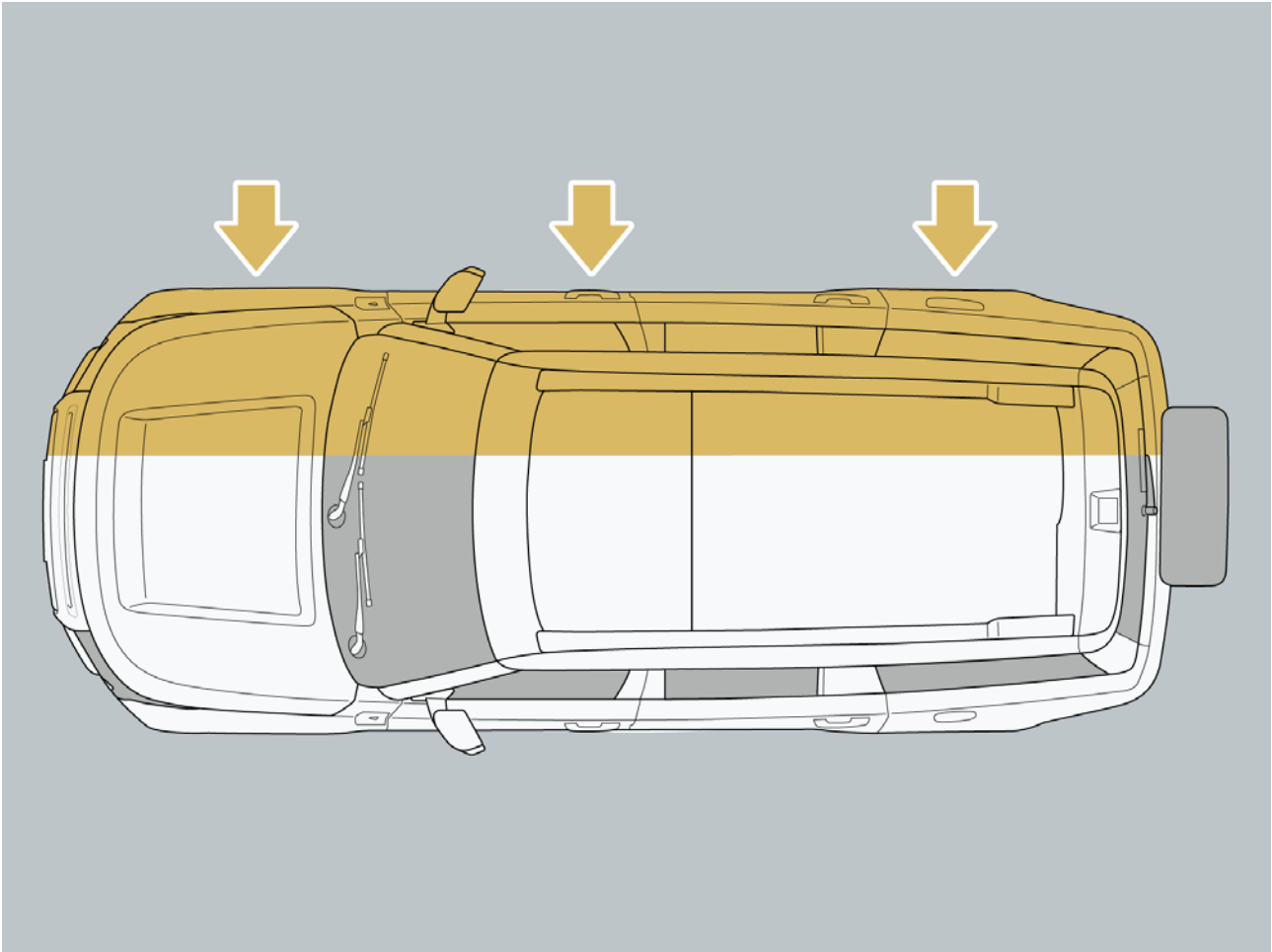

4 Safety instructions

2. Rear collision or rear-ended.

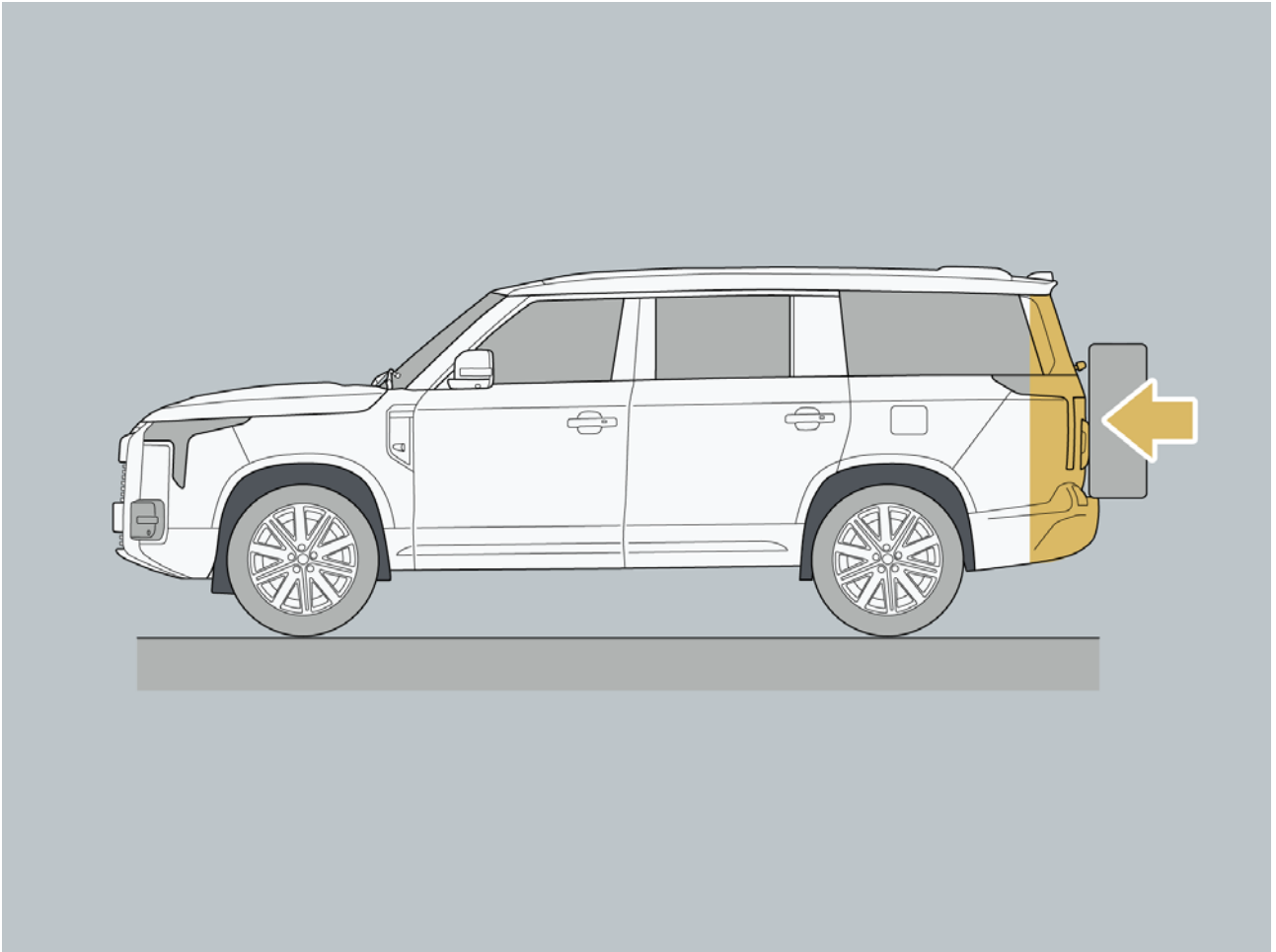

4 Safety instructions

3. Rollover.

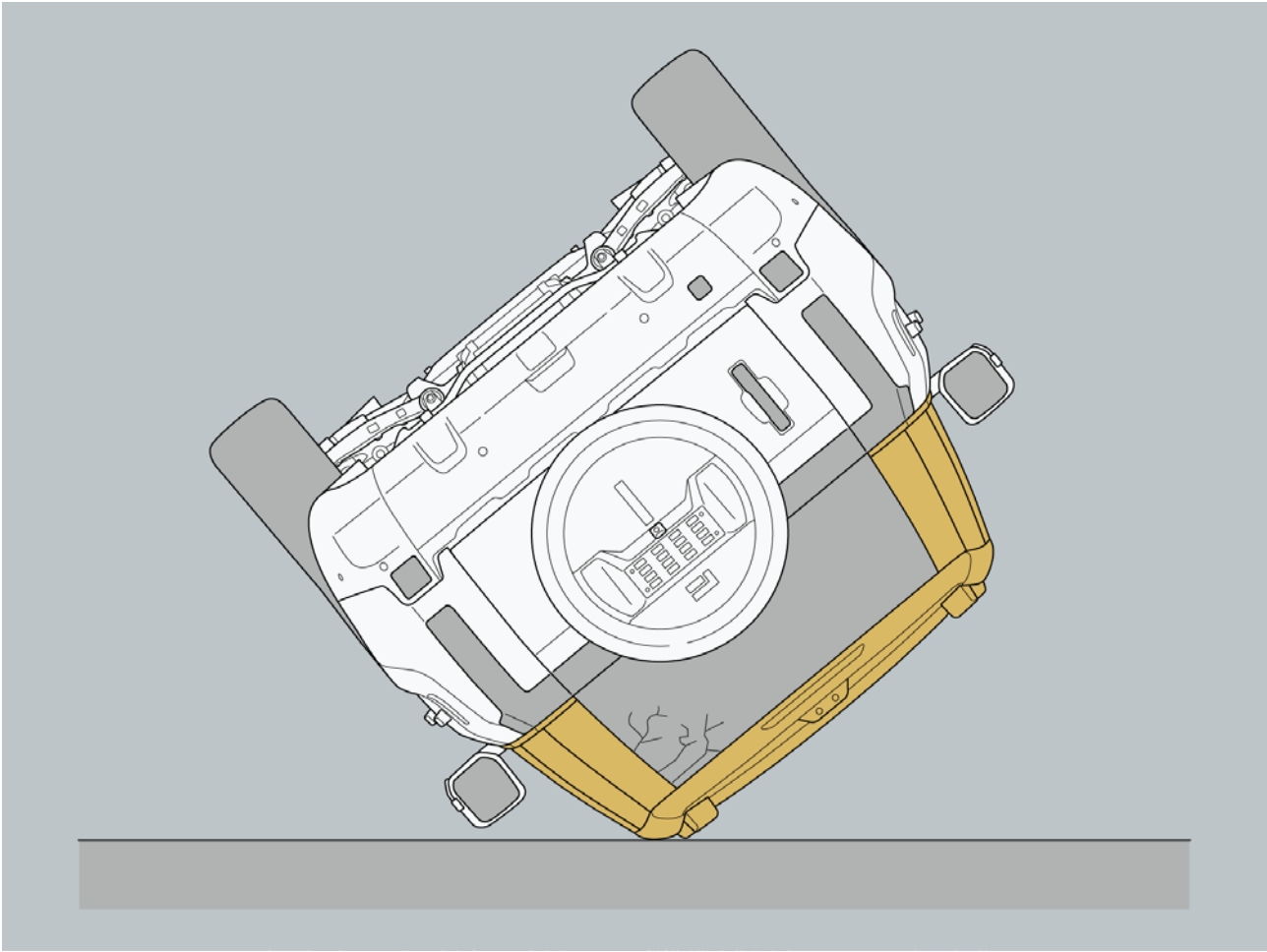

4 Safety instructions

4. When the vehicle collides at low speed with small objects such as utility poles or slender trees, the airbag may not be deployed.

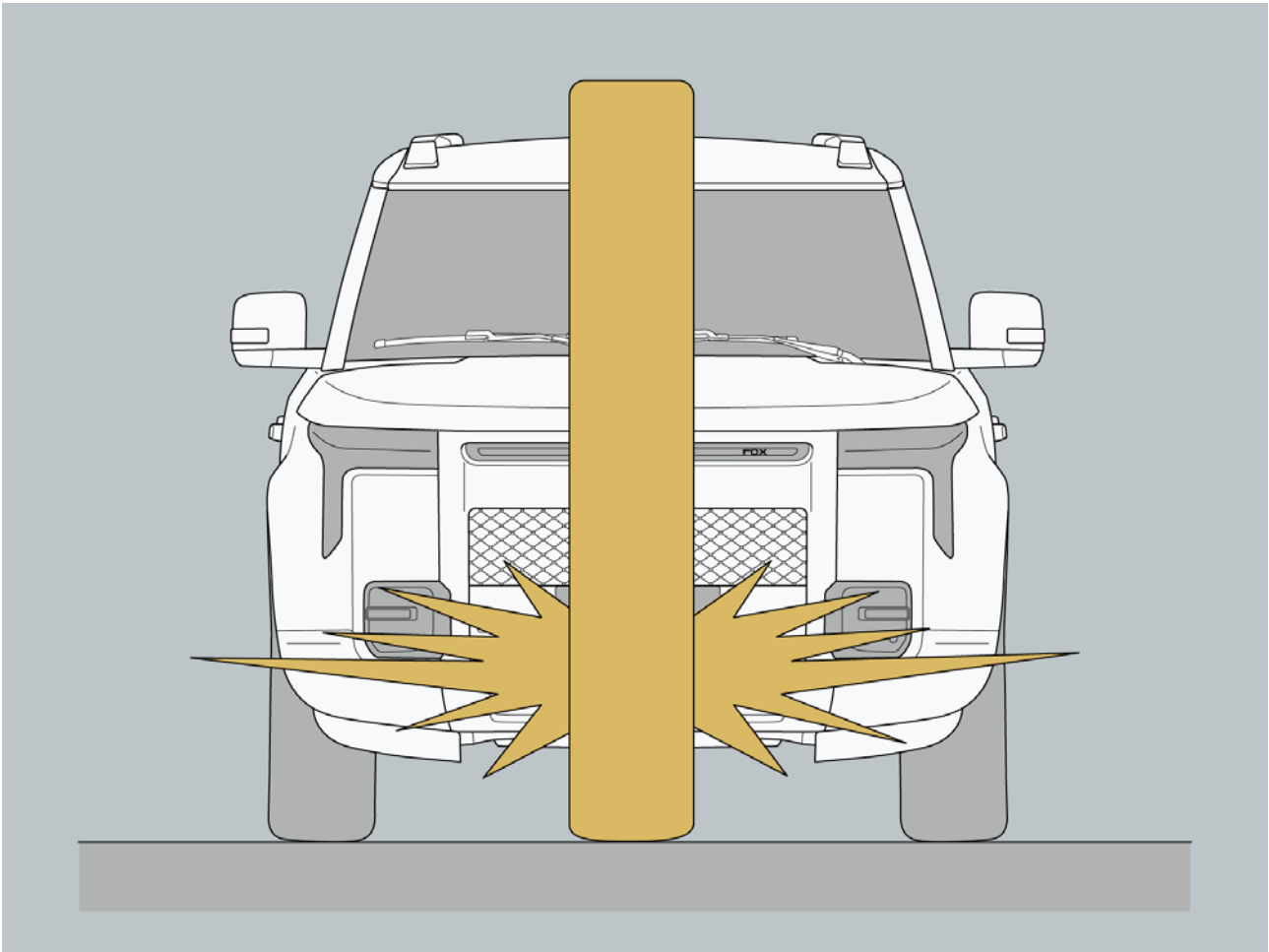

4 Safety instructions

5. If a rear collision occurs underneath the rear of a truck, the airbag may not be deployed.
6. If the collided object deforms or moves, the impact force caused by the collision will be reduced, and the airbag may not be deployed.

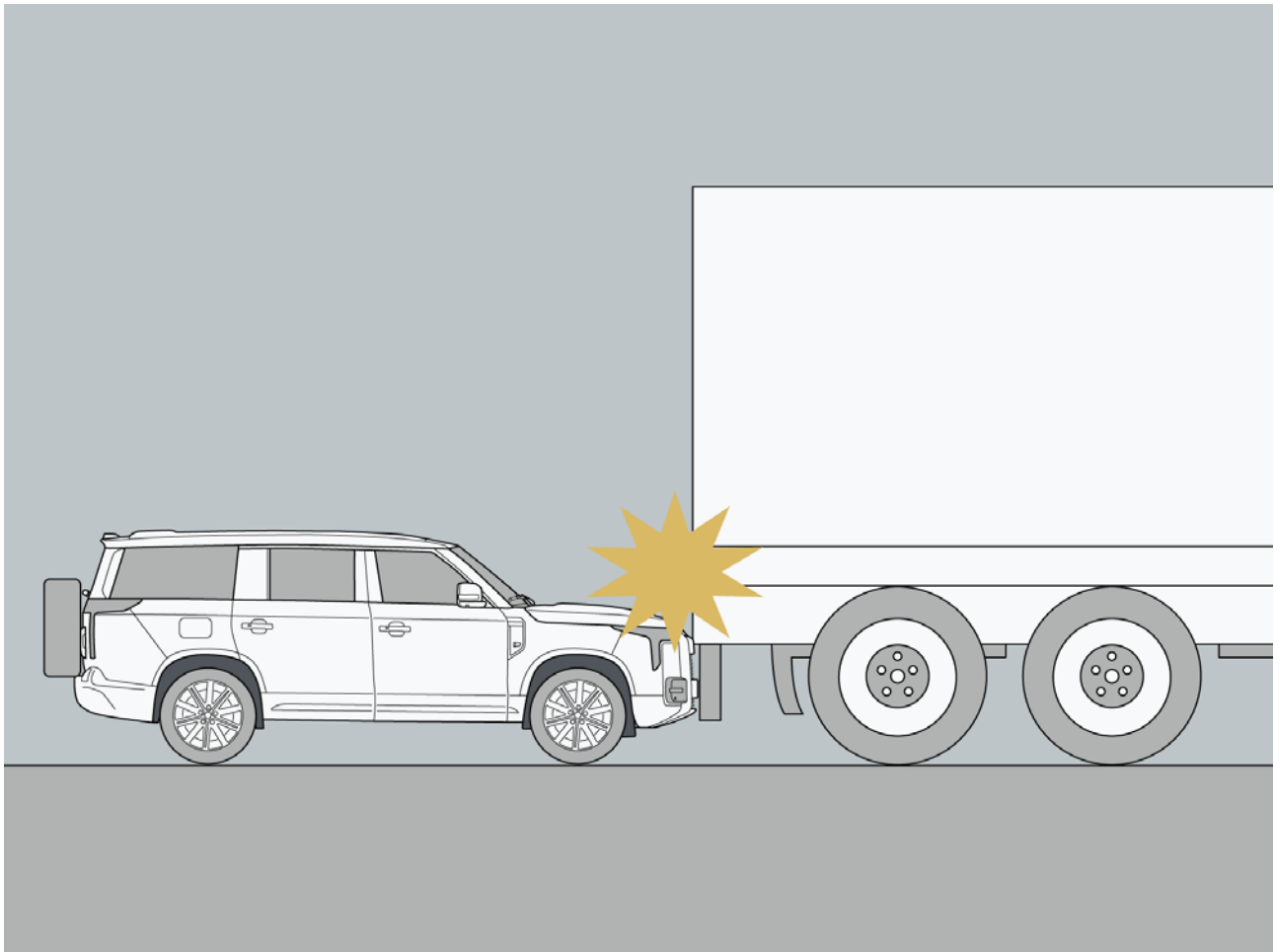

VI. Impossible deployment of side air curtains and side airbags

1. When the vehicle suffers a low-speed side collision or rear collision.

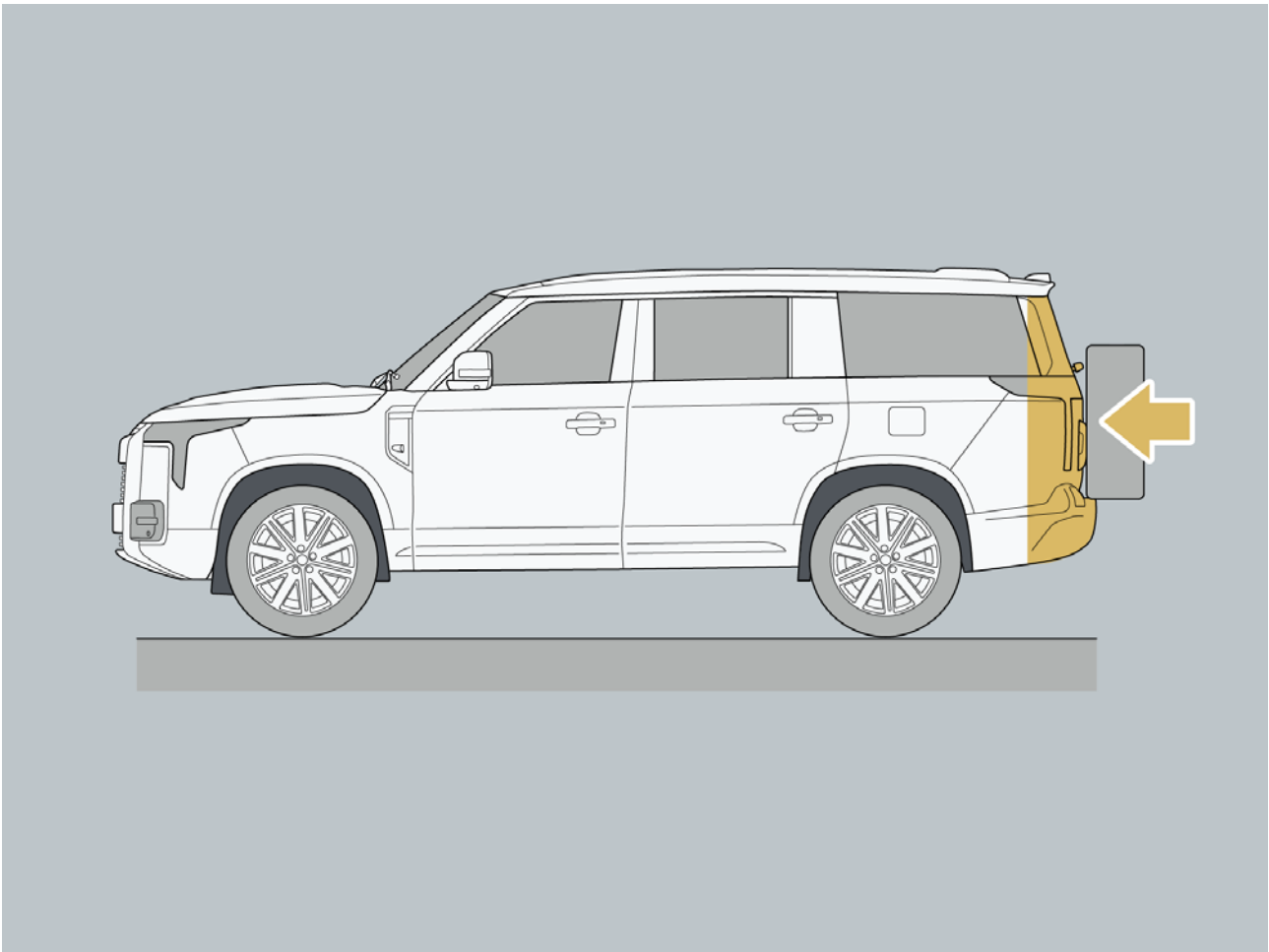

4 Safety instructions

2. The side is scratched.

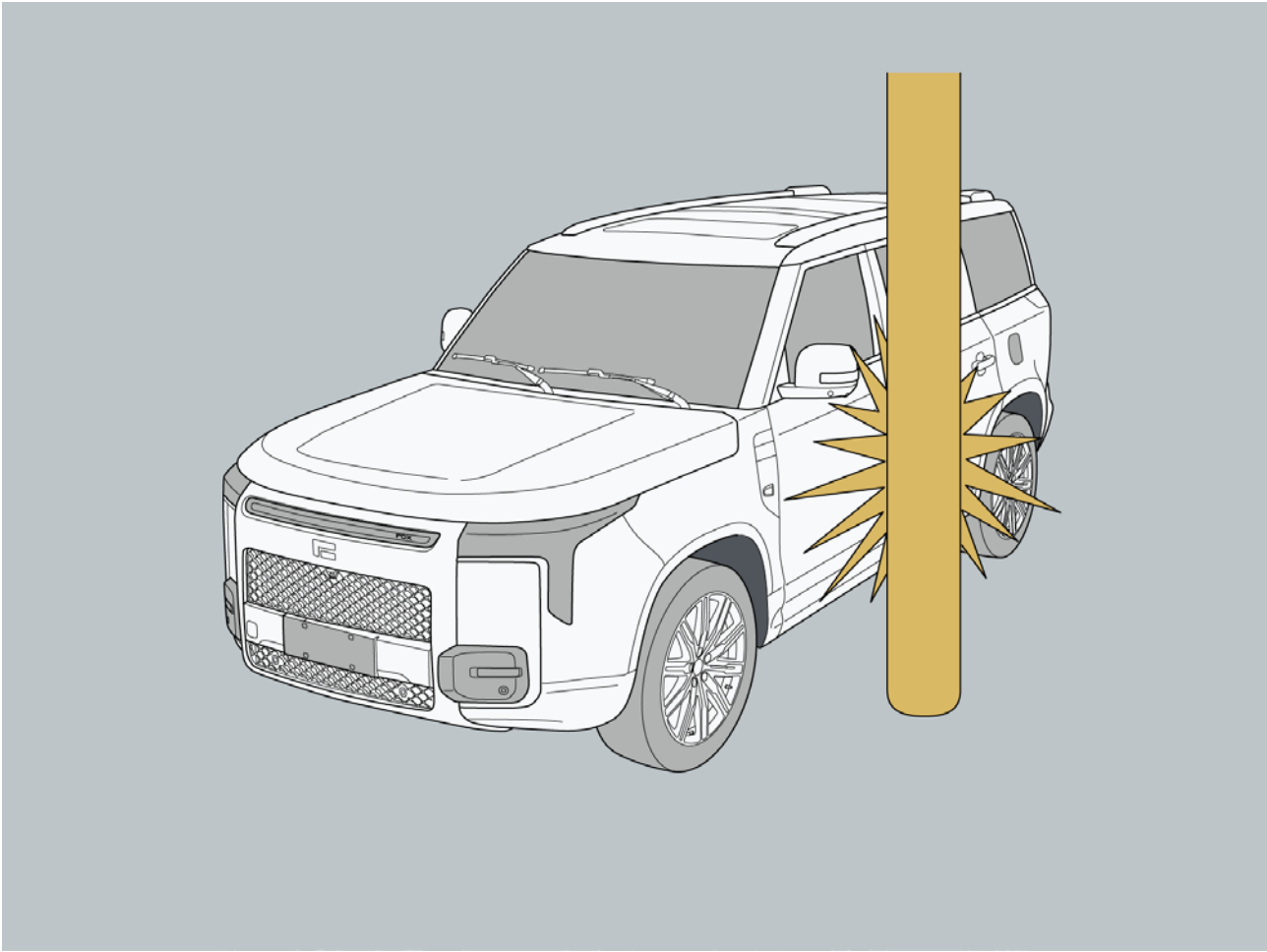

4 Safety instructions

3. The body of a non-passenger car suffers a side collision.

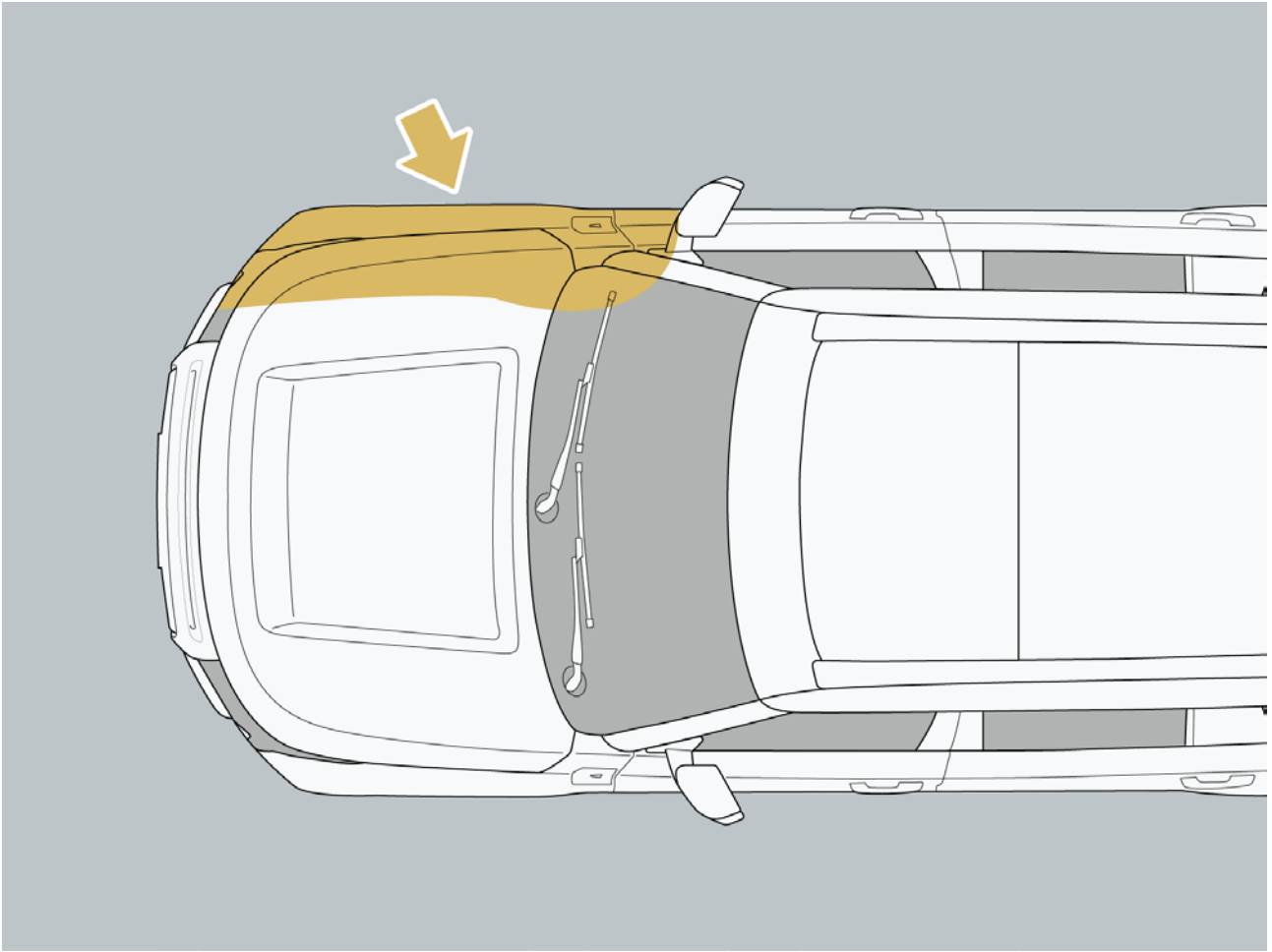

4 Safety instructions

VII. Install seat covers on the seats

Do not install seat covers and other items on the vehicle seats. The seat covers may affect the normal deployment of the side airbags in case of a collide, thus failing to effectively protect the drivers and passengers.

Warning

- Do not touch the accessories of the airbag after its deployment to avoid burns.
- The protection function of the airbag system can only be triggered once. If the airbag has been triggered, be sure to replace it. It can prevent from failing to play a protective role in case of a collision.
- Do not drive the vehicle when the airbag (such as the steering wheel trim cover) is damaged or cracked, so as to avoid serious personal injury caused by the sudden deployment of the airbag or the failure to deploy in an accident.
- Do not hit the airbag assembly hard to avoid accidental deployment of the airbag.
- Do not install accessories and other items on the dashboard to avoid secondary damage caused by the deployment of the airbag.
- Do not hang any hard objects (such as clothes hangers, glass bottles, etc.) at the coat hook to prevent secondary damage caused by the detonation of the side air curtain.
- Do not place your feet or other parts of your body on the airbag during driving, so as to prevent secondary injury caused by the deployment of the airbag in an accident.
- Do not disassemble or install airbag components without authorization.
- Do not hold an infant or a child on your knees. Otherwise, the infant or the child will be seriously injured or even killed in a collision. All infants and children should be properly protected by child safety seats or seat belts in the rear seats.

Caution











- As a supplemental safety system, the airbag cannot replace the seat belt in respect of protection. It must be used together with the seat belt to provide the best protection for the driver and passengers. Therefore, all driver and passengers in the car must fasten the seat belt and maintain the correct sitting position.

Hint

- If the airbag is not activated at the time of collision, it does not indicate that the airbag is faulty. The strength or type of collision is not enough to activate the airbag.

4.1.5 High voltage system

I. Emergency rescue information

Icon	Name	Icon	Name
	High voltage part		Air-spring air storage cylinder
	Airbag		Fuel tank
	Stiffener		Airbag controller
	Seat belt pretensioner		Side air curtain cylinder
	Low voltage battery		Air spring
	Air spring		

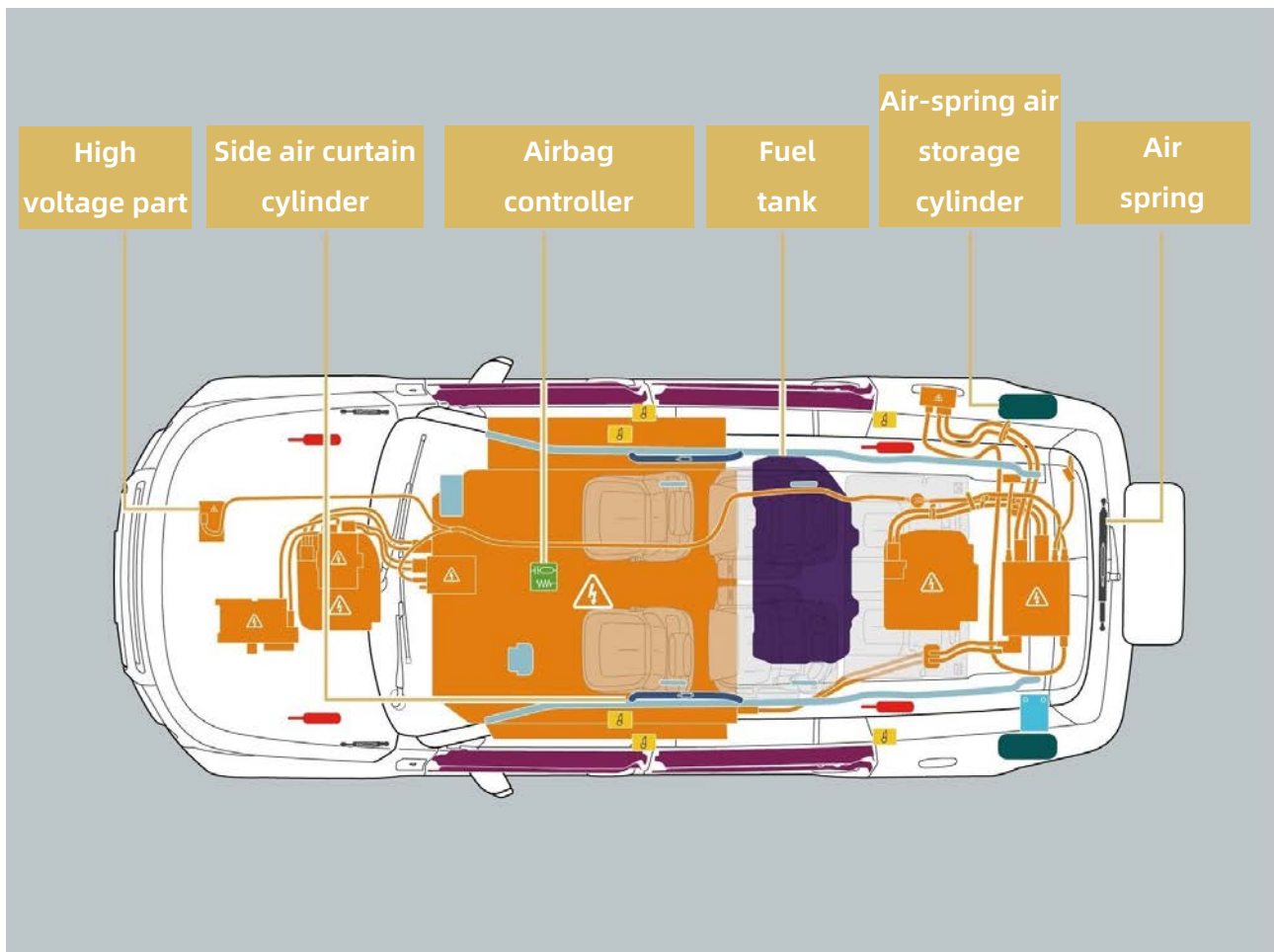

4 Safety instructions

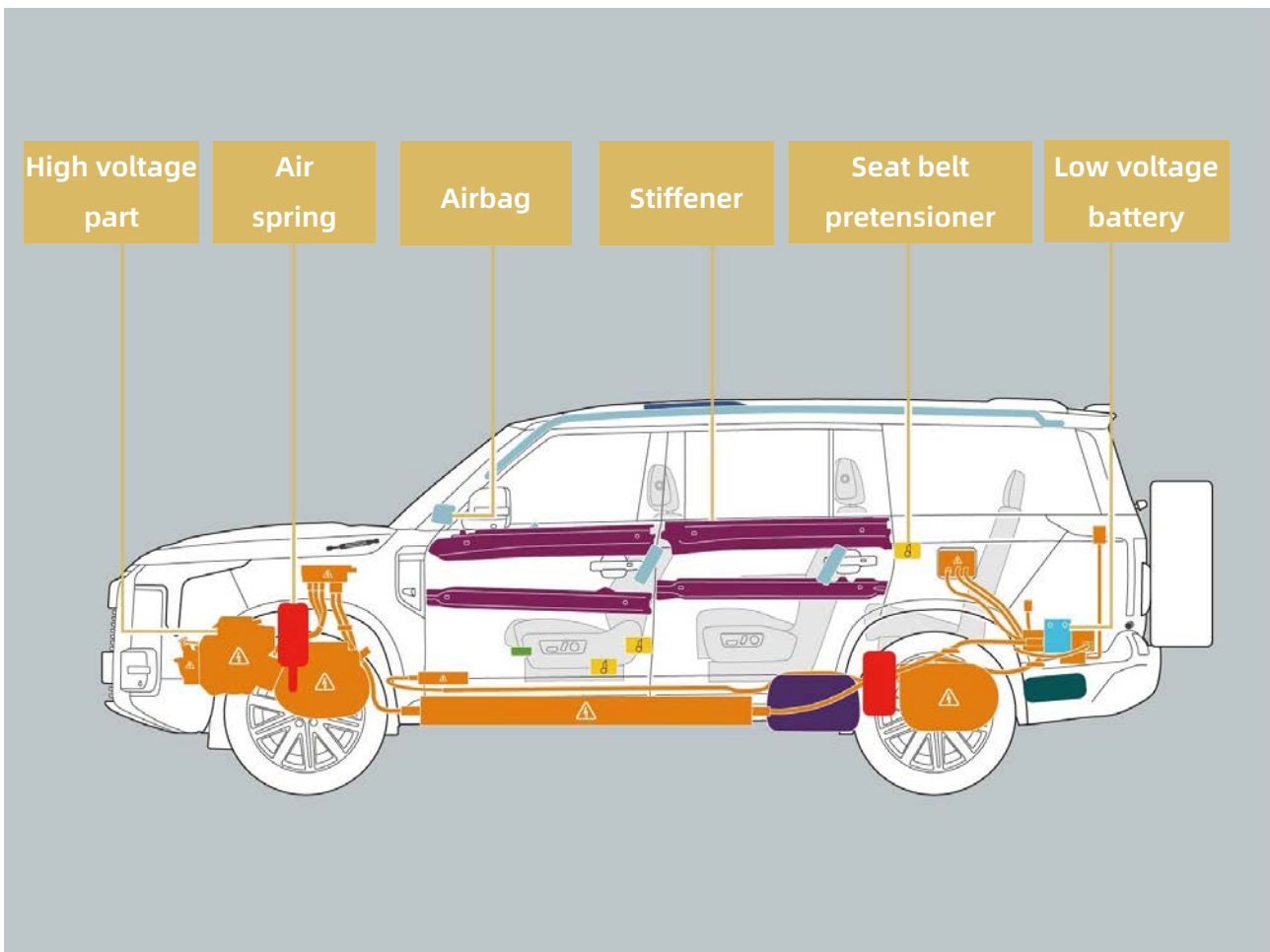

II. Automatic shutdown of high-voltage system

In the event of a serious collision, the high-voltage system will be cut off urgently to avoid threatening the driver, passengers and other traffic participants.

4.1.6 Precautions for waste gas

The exhaust gas emitted by the vehicle contains colorless and odorless harmful substances, such as carbon monoxide (CO), particulate matter, etc. Staying in an environment with high exhaust gas content for a long time will endanger health and even lead to death due to inhalation of too many harmful substances. If you are uncomfortable due to inhalation of too much exhaust gas, you should move to an open area as soon as possible. If it is serious, please seek medical attention in time.

Warning

- Carbon monoxide gas is poisonous. Inhalation in large quantities will lead to loss of consciousness and even death.
- Do not operate the range extender system for long time in a poorly ventilated environment.
- When the car doors and trunk doors are closed and the car exhaust can still be smelled, it is necessary to open the windows in time for ventilation and contact ROX Service Center for timely maintenance.
- When the vehicle is stationary, avoid running the range extender system for a long time in a place with deep snow or in snowing.
- The exhaust pipe may have small holes or cracks due to corrosion, damaged joints or abnormal exhaust noise, etc. In this case, do not continue to drive, and contact ROX Service Center.

4 Safety instructions

4.2 Child safety

4.2.1 Child safety information

I. When the child is in the car

1. When traveling with a child under the age of 12 or under 1.5 m in a car, be sure to install a child safety seat or safety seat cushion for the child. Let the child sit on the child safety seat or safety seat cushion instead of hugging or sitting on the knee, so as to fully protect the safety of children in the car.
2. For installation details, please strictly follow the manual attached to the child safety seat. This manual provides general installation instructions.
3. Child seats should be installed on the rear seats to prevent children from mistakenly touching the shift system, etc., and ensure to have children's seat belts fastened throughout the journey.
4. For the sake of safety, install the child seat at the second/third-row of seats.
5. When children are in the car, please enable the rear door child safety lock to avoid children opening the windows or doors while driving.
6. Do not allow children to operate any equipment, such as windows, doors, sunshades, etc., that may jam or clamp the body.
7. Do not leave children in the vehicle alone.

II. Forbidden to install child seats in the front passenger seat

Do not install a child seat on the front passenger seat, and avoid children being too close to the airbag. In case a collision, the deployed airbag may cause serious injury or even death to the children.

Hint

- A warning sign is affixed to the right sunshade, reminding front occupants of the dangers of front airbags. Be sure to read and follow the instructions on the sign.



WARNING



DO NOT place rear-facing child seat on this seat with airbag

DEATH OR SERIOUS INJURY can occur

4 Safety instructions

4.2.2 Child safety seat

I. Applicable information for child safety seats in different seating positions

Seating position													
Seating position	7-Seater (223)				6-Seater (222)				7-Seater (232)				Other positions
	4	6	7	9	4	6	7	9	4	6	7	9	
Seat positions suitable for universal seat belts (Yes/No)	Yes	Yes	No.	No.	Yes	Yes	No.	No.	Yes	Yes	No.	No.	No.
Seat position suitable for i-Size (Yes/No)	Yes	Yes	No.	No.	Yes	Yes	No.	No.	Yes	Yes	No.	No.	No.
Seat position suitable for lateral fixing module (L1/L2) (Yes/No)	No.	No.	No.	No.	No.	No.	No.	No.	No.	No.	No.	No.	No.
Seat position suitable for the largest rear-facing fixing module (R1/R2X/R2/R3)	Yes	Yes	No.	No.	Yes	Yes	No.	No.	Yes	Yes	No.	No.	No.
Seat position suitable for the largest front-facing fixing module (F2X/F2/F3)	Yes	Yes	No.	No.	Yes	Yes	No.	No.	Yes	Yes	No.	No.	No.
Seat position suitable for the largest height-increasing seat fixing module (B2/B3)	Yes	Yes	Yes	No.	No.	No.	No.	No.	Yes	Yes	Yes	Yes	No.

4 Safety instructions

Note: The meaning of the letters in the above table:

- L1/L2: Left-side CRS/ right-side CRS;
- R1: CRS For rear-facing infant;
- R2X/R2: Reduced size CRS for rear-facing toddler learning to walk;
- R3: Full-size CRS for front-facing toddler learning to walk;
- F2X/F2: Reduced-height CRS for front-facing toddler learning to walk;
- F3: Full-height CRS for front-facing toddler learning to walk;
- B2: Raise the seat and reduce the width to 440mm;
- B3: Raise the seat, with full width 520mm.

Seating position number	The position on the vehicle
1	Front row left
2	Front row middle
3	Front row right
4	Second row left
5	Second row middle
6	Second row right
7	Third row left
8	Third row middle
9	Third row right

Caution

- When using a non-universal child safety seat, please carefully verify the adaptability of the device with the relevant child safety seat manufacturer or such seat retailer.

II. Fixing methods used for child safety seats

This vehicle provides a variety of fixing methods for the child safety seat. You can choose to use one or multiple methods to fix the child safety seat or cooperate with multiple ways to fix it according to the requirements of the manual attached to the child safety seat.

1. Fix the seat belt

4 Safety instructions



2. ISOFIX anchor

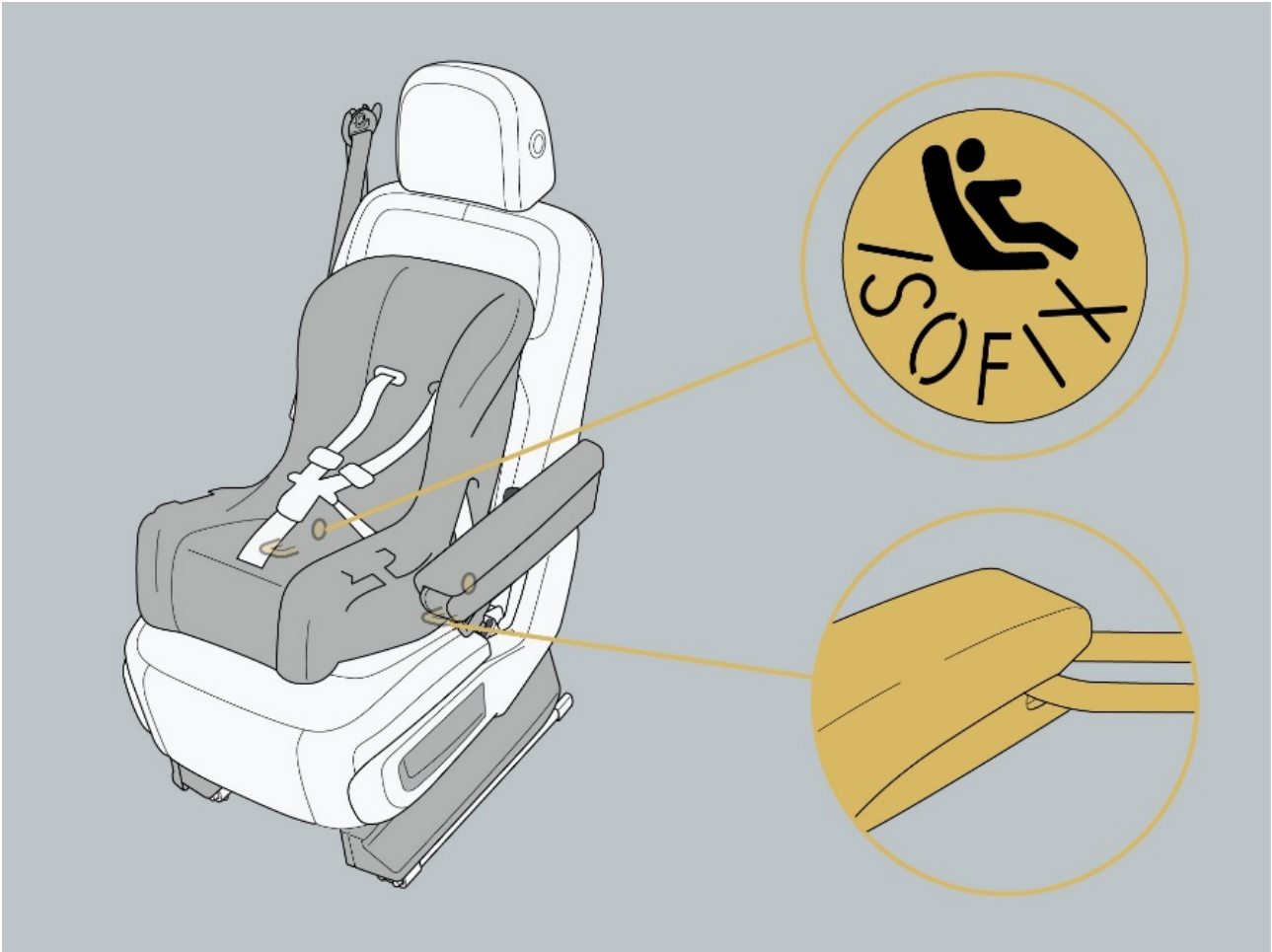

4 Safety instructions

3. ISOFIX pull-up strap anchor



4.2.3 Installation of child safety seat

It is recommended to use the Globalkids Talent PLUS child safety seat for children weighing no more than 18 kg (approx. 3 years old). When using the child safety seat, the reverse installation method must be used.

Please install the child safety seat according to the manual attached to the child safety seat. This manual provides general installation instructions.

I. Install child safety seat with seat belt

1. If the headrest interferes with installation of child safety seat, remove it or raise it to the highest position.
2. Adjust the position of the second-row seat: When installing in the second-row seat, adjust the second-row seat to the rearmost position; When installing in the third-row seat, please adjust the second-row seat to the foremost position.
3. Place the child safety seat facing the front of the vehicle in the second/third-row seat.



4 Safety instructions

4. Adjust the backrest angle of the second/third-row seat. The backrest of the front-facing child safety seat must be as closely aligned as possible with the seat backrest.
5. Pass the untwisted seat belt through the child safety seat and insert it in the seat belt buckle.
6. Shake child safety seat to ensure that it is firmly installed.



II. Install child safety seat with ISOFIX anchor

1. If the headrest interferes with installation of child safety seat, remove it or raise it to the highest position.
2. Adjust the position of the second-row seat: When installing in the second-row seat, adjust the second-row seat to the rearmost position; When installing in the third-row seat, please adjust the second-row seat to the foremost position.
3. Connect the ISOFIX connector of the child safety seat to the ISOFIX anchor of the seat and ensure that the ISOFIX connector is firmly secured.

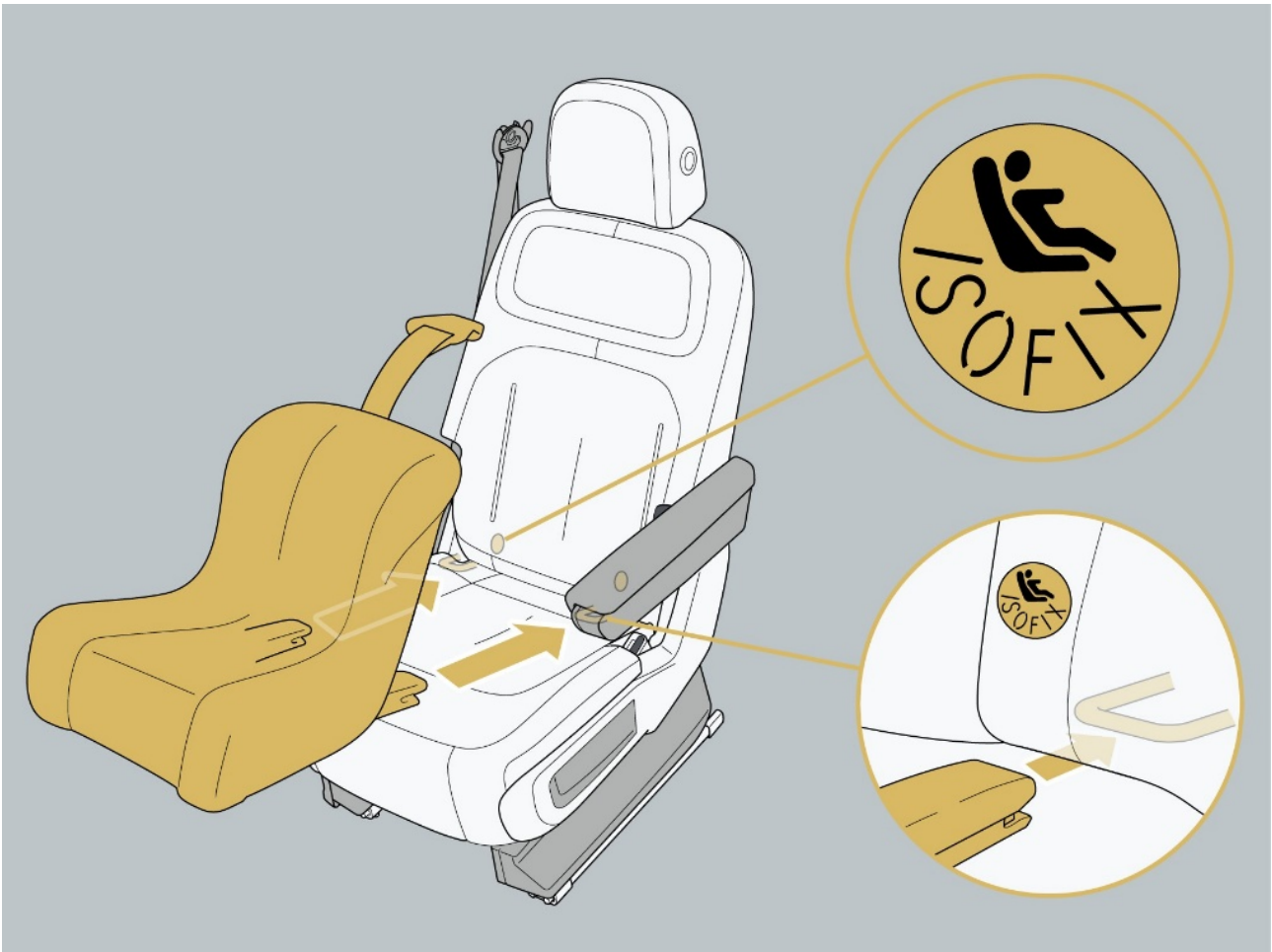

4. Adjust the backrest angle of the second/third-row seat. The backrest of the front-facing child safety seat must be as closely aligned as possible with the seat backrest.
5. Pass the untwisted child safety seat pull-up strap through between the two headrest bars under the headrest and fix it on the ISOFIX pull-up strap anchor. Tighten the pull-up strap of the child safety seat to avoid loosening.
6. Shake child safety seat to ensure that it is firmly installed.

4 Safety instructions

Warning

- Install the child safety seat correctly. Be sure to install the child safety seat according to the installation instructions provided by the manufacturer, so as to prevent the child safety seat from being unable to provide protection the event of an accident.
- After the child seat is installed, do not continue to adjust the seat to avoid displacement of the seat. This would prevent the child safety seat playing its role.

Caution

- ISOFIX rear-facing child safety seat can only be installed on the second-row seat.
- For children weighing no more than 18 kg, the child safety seat must be rear-facing installed.



4.2.4 Child safety lock

A child lock is a device designed to ensure the safety of children in vehicles. It can prevent children from accidentally opening doors, windows or equipment in the vehicle during driving, thus avoiding danger. It is recommended to enable the child lock when the child is sitting in the rear seat.

I. Setting child lock

Click "Vehicle Settings → Vehicle → Door and Window Locks → Child Lock Area" on the central control screen to select and activate the child locks on both sides.

II. Activate and deactivate

The child lock key is located at the driver's side window.

- Activation: Press the button of the child safety lock, the button indicators up, and the child safety lock is activated.
- Deactivation: After the child safety lock is activated, press the child safety lock button, the button indicator goes out, and the child safety lock is deactivated.

Caution

- When there are children in the car, please activate the child safety lock.

Hint

- After the child lock is activated, the corresponding rear door cannot be opened from the inside. Do not leave children alone in the car to avoid accidental injuries.
- After activating the child safety lock, the corresponding door cannot lift the window.

4 Safety instructions

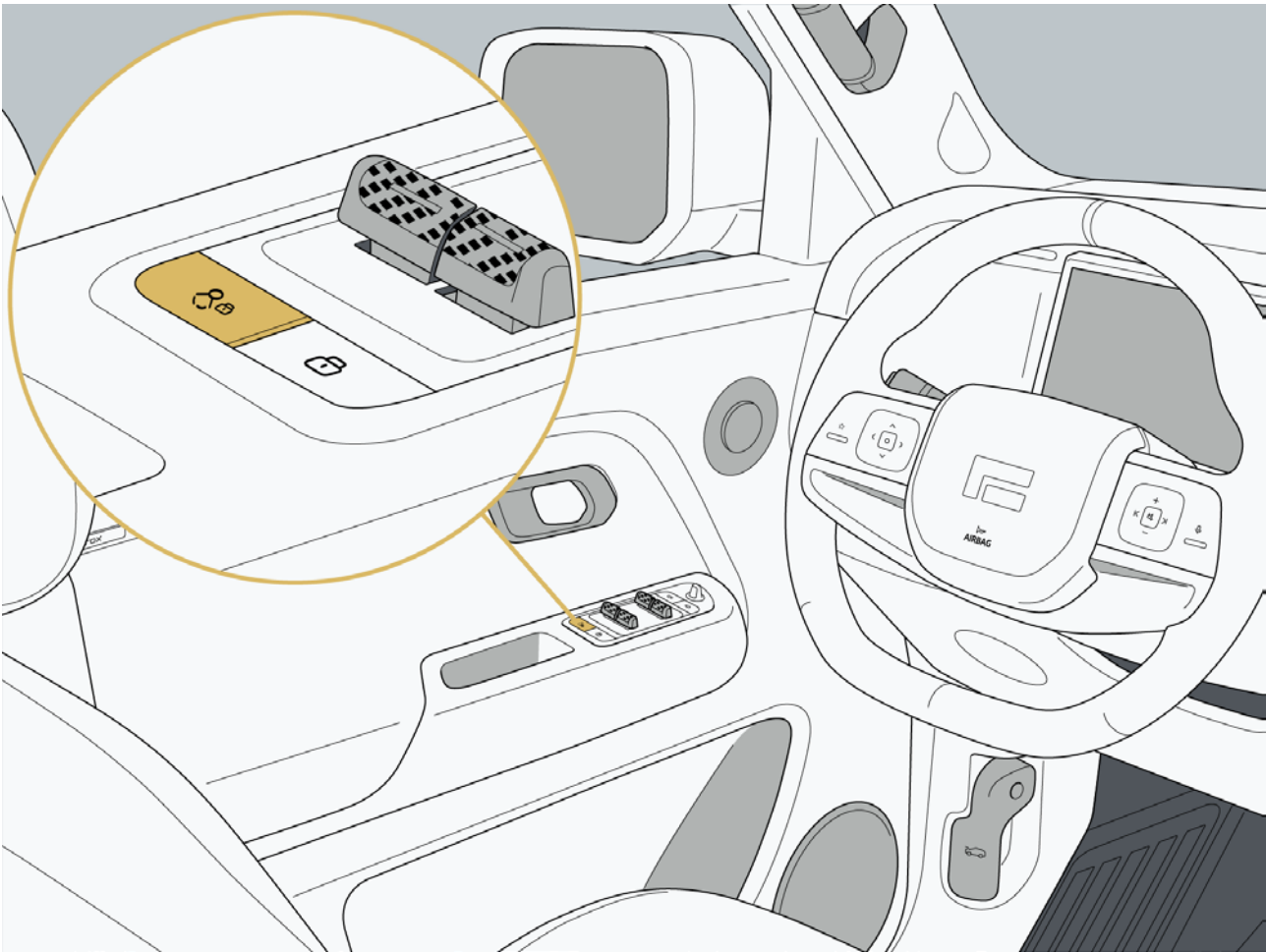

4.3 Range extender system

4.3.1 Range extending system feature

Range-extended vehicles are driven only by motors, not by range extenders. The only function of the range extender is to power the drive motor and the battery.

S/N	Name	S/N	Name
1	Range extender	2	Front drive motor
3	Power battery	4	Rear drive motor

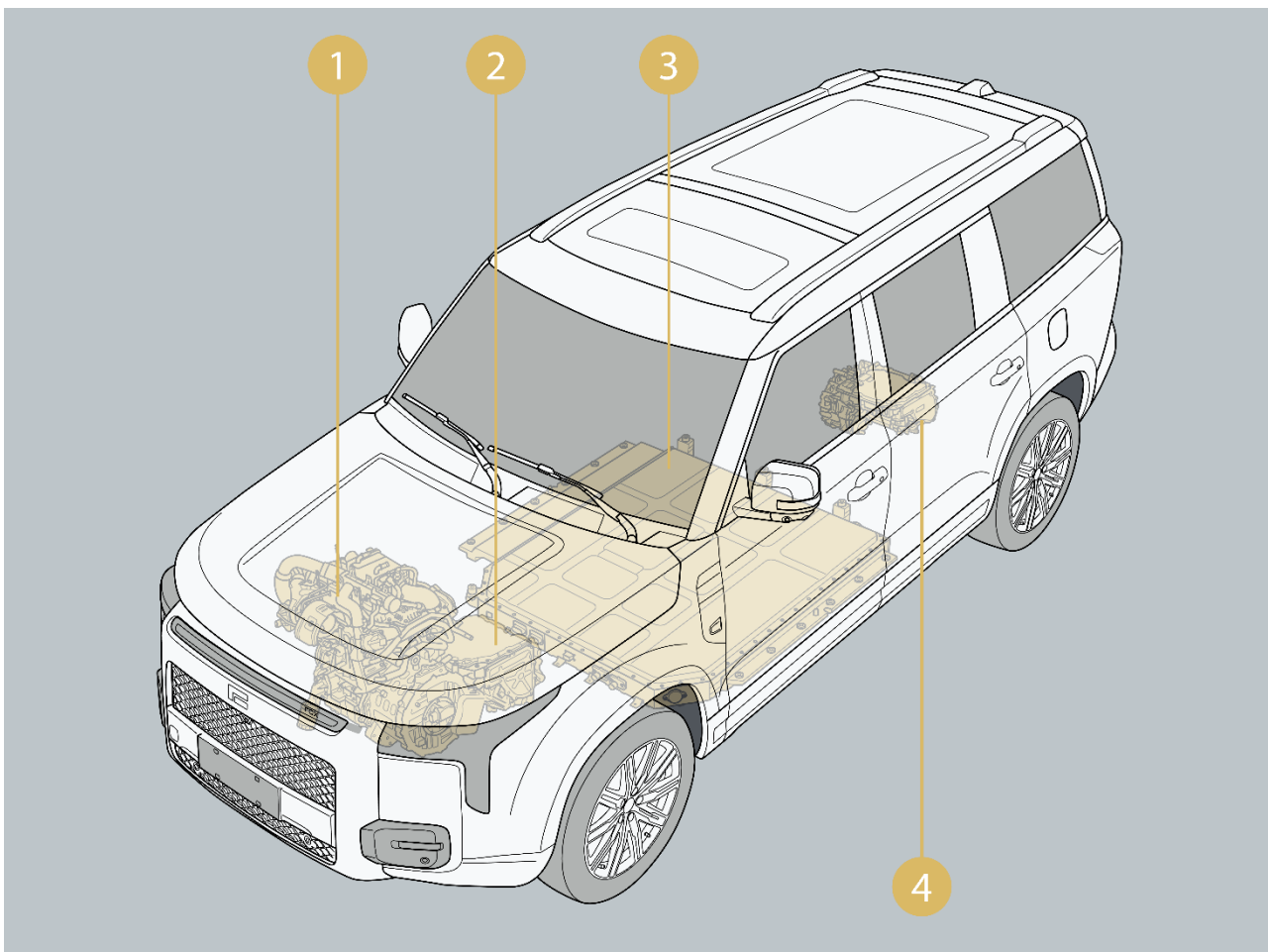

I. Energy mode

Three energy modes are provided for this car: pure electric priority, fuel priority and hybrid.

Click the option under "Vehicle Settings → Vehicle → Driving → Energy Mode" on the central control screen to switch the energy mode.

- Pure electric priority: The vehicle gives priority to driving with the energy provided by the power battery. When the power battery level is consumed to a certain value, the range extender will replenish the energy to maintain the appropriate power battery level. After selecting the pure electric priority mode, you can set the ultra-long pure electric function. Turning on the ultra-long

4 Safety instructions

pure electric power can use more power battery level and increase the pure electric mileage of the vehicle.

- Fuel priority: When the power battery level is lower than a certain value, the vehicle gives priority to driving with the energy provided by the range extender, which has a high power battery level retention capacity. After selecting the fuel priority mode, you can set the forced power generation function.
- Hybrid: The vehicle intelligently distributes the energy use of the power battery and range extender to maintain an appropriate power battery level.

Hint

- Low-battery level will weaken the vehicle power. It is not recommended to use the ultra-long pure electric function frequently.
- After activating the forced power generation function, the fuel consumption will increase. It is recommended to use it when there is a temporary demand for driving charging.
- When the fuel is exhausted or the range extender cannot be started, the power battery will continue to be consumed. Please replenish the fuel in time.

II. Power mode

This car provides four power modes: comfort, standard, sport, and sport+. Users can choose the appropriate power mode according to driving habits.

Click the option under "Vehicle Settings → Vehicle → Driving → Power" to switch the power mode.

- Comfort: gentle power response.
- Standard: moderate power response.
- Sport: faster power response.
- Sport+: best dynamic performance and optimum power response.

Only the spiral spring version of the vehicle can be switched to the previous or next mode by moving the lever forward or backward. The switching sequence is: Comfort → Standard → Sport → Sport +.

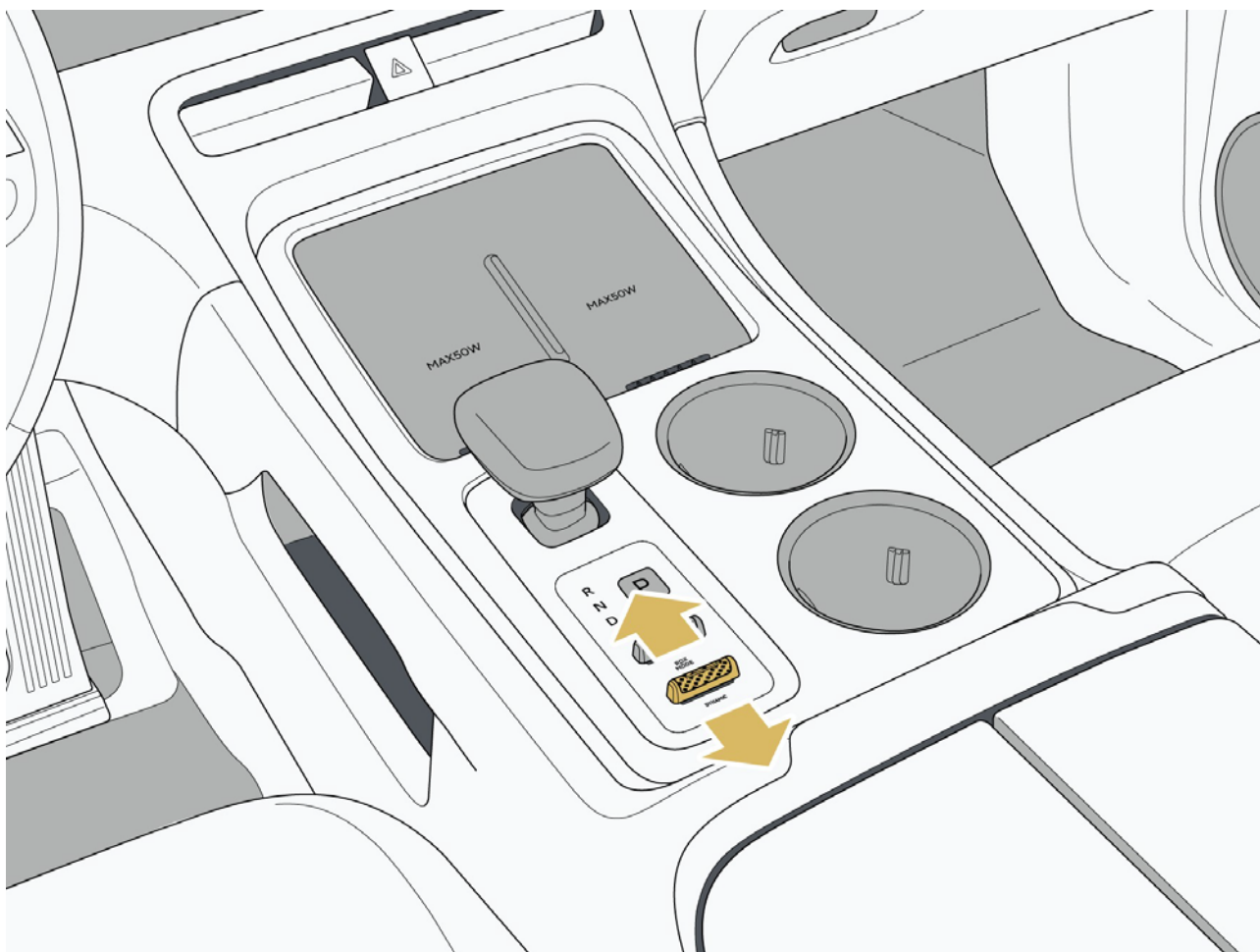

4.3.2 Precautions for range extending

Fuel and power cut-off in case of a collision

In the event of a serious collision accident, the high-voltage power supply system and fuel supply system will be cut off urgently. It can minimize the risk of accident.

After a collision and cut-off of power and fuel, the vehicle will not be able to restart. Please contact ROX Service Center in time.

Warning

- Do not touch the parts of the high voltage system to avoid electric shock.
- Do not touch the fluid leaked from the vehicle to avoid personal injury.
- Do not touch the high-voltage wiring harness exposed in or outside the car to avoid electric shock.
- Keep away from a burning vehicle.

4 Safety instructions

4.4 Anti-theft system

4.4.1 Anti-theft system

If the anti-theft system is enabled, when the vehicle is detected to be abnormally invaded, the vehicle will enter the anti-theft alarm state. At this time, the turn signal lamp flashes and the horn continues to sound for 30 s. If it is re-triggered during the alarm process, it will still last for 30s. If it is triggered again after the alarm is ended, the turn signal lamp will continue to flash and the horn will continue to sound for 30s. It can be repeated 10 times in an anti-theft cycle.

I. Enable anti-theft mode

Lock the vehicle from outside with the doors, trunk doors and hood closed, and the anti-theft system will be enabled. Or after unlocking the vehicle, if the door or trunk door is not opened within 30 s, the door will be automatically locked. At the same time, the anti-theft system will be enabled.

II. Trigger an alarm

When the anti-theft system is enabled, an alarm will be triggered when:

- Opening any door, hood or trunk door without a remote key.
- Opening the door without carrying a legal key.

III. Shut down the anti-theft system

Any of the following will shut down the anti-theft system:

- Unlock the door with the remote key.
- The vehicle is in "READY" mode.

Warning

- Do not modify the remote key without authorization to avoid that the remote key cannot unlock/lock the vehicle.
- When leaving the vehicle, do not leave the remote key in the vehicle. Otherwise, you may not be able to lock the vehicle.
- When locking the vehicle, do not leave children or pests in the vehicle alone.

5.1 Instrument and central control system

5.1.1 Instrument screen

5.1.1.1 Instrument screen overview

When you are using the vehicle, the instrument panel will display the operating parameters and status of the vehicle. Please be sure to read this part carefully.

1	Instrument indicator display area	Through the warning lamps and indicators displayed on the instrument screen, the working status of each system is displayed for the driver.
2	Time	Display the current time.
3	Gear information	Display the current vehicle gear information.
4	Temperature display	Display the current regional temperature.
5	Instrument indicator display area	Through the warning lamps and indicators displayed on the instrument screen, the working status of each system is displayed for the driver.
6	Energy mode	Display the current energy mode: pure electric priority, fuel priority, and hybrid.
7	Pure electric range	Display the possible mileage with the current remaining power.
8	Pure oil range	Display the possible mileage with the current remaining fuel.
9	Instantaneous power percentage	Represents the percentage of instantaneous power to maximum power when the current output power or energy is recovered
10	Total mileage	Display the current total mileage of the vehicle.
11	Left information display area	Switch cards such as vehicle tire pressure and multimedia information through the steering wheel buttons.
12	READY indicator	This light is on to indicate that the vehicle is in a drivable status.
13	Vehicle speed information	Display the current speed information of the vehicle.
14	Right information display area	Switch cards such as map navigation, vehicle information and power through the steering wheel buttons.
15	Hybrid comprehensive mileage	The overall range of the vehicle in hybrid mode.
16	Driving mode	Displays the current driving mode: Comfort, Standard, Sport, Sport +, AUTO, Deep Snow, Mud, Rock, Sand, Wade.

5 Information display





















5.1.1.2 Warning lamps and indicators









I. Indicator

Illustration	Name
	Seat belt unfastened warning light
	Left turn signal indicator
	Right turn signal indicator
	Hazard warning lamp
	Position lamp indicator
	Rear fog lamp indicator
	Low-beam headlight indicator
	High-beam headlight indicator
	Automatic high-beam headlight indicator
	Anti-theft authentication failed indicator

5 Information display

Illustration	Name
	Electronic handbrake brake indicator
	Hill descent control indicator
	AutoHold indicator
	READY indicator
	Charging gun connecting status indicator
	Low fuel indicator
	Low power battery level indicator
	High-voltage disconnection indicator
	ESP off indicator light
	ACC-to-be-activated indicator
	LCC-to-be-activated indicator
	CC-to-be-activated indicator
	CC activation indicator light
	Excessive slope indicator
	Depress the brake pedal
	Road icing indicator
	Traction mode indicator light
	Trailer mode indicator light





III. Warning lamp

Illustration	Name
	High coolant temperature indicator light
	Brake system fault and low brake fluid level warning lamp
	Lighting system fault warning lamp
	Emission system fault warning lamp
	Airbag system fault warning lamp
	Low oil pressure indicator
	ABS system fault warning lamp
	EBD system fault warning lamp

5 Information display

Illustration	Name
	Electronic handbrake fault warning lamp
	Serious power system fault warning lamp
	Power system general fault warning lamp
	Limited drive system power indicator
	Electric steering system fault indicator light
	Drive motor over-temperature warning lamp
	Drive motor fault warning lamp
	Low battery power level and battery system fault indicator
	Power battery over-temperature warning lamp
	Battery heat diffusion warning lamp
	Wading warning lamp
	Range extender maintenance self-starting warning lamp
	Abnormal tire pressure and temperature and tire pressure monitoring system fault warning lamp
	ESP system fault warning lamp
	Hill descent control fault warning lamp
	EBD system fault indicator
	AEB system fault warning lamp
	Air suspension system fault indicator light
	Shock absorbing system fault warning lamp
	Sensing unit fault warning lamp
	Navigation function fault warning lamp
	PDC system fault warning lamp
	Assisted parking system fault warning light
	AVM system fault warning lamp
	HAVP system fault warning lamp
	BSD function fault warning lamp
	RCW system fault warning lamp

5 Information display

Illustration	Name
	FCTA system fault warning lamp
	DVR fault warning lamp
	DMS system fault warning lamp
	AutoHold system fault warning lamp

Note: When the above warning lamp appears, contact ROX Service Center in time.

5 Information display

5.1.2 Central control screen

5.1.2.1 Central control screen overview

By using the central control screen, you can conveniently set up the vehicle, operate its functions and view information, etc. You can also use the central control screen to customize the state of the vehicle according to your preferences and enjoy a comfortable driving experience.

S/N	Name
1	Status bar
2	Bottom function bar

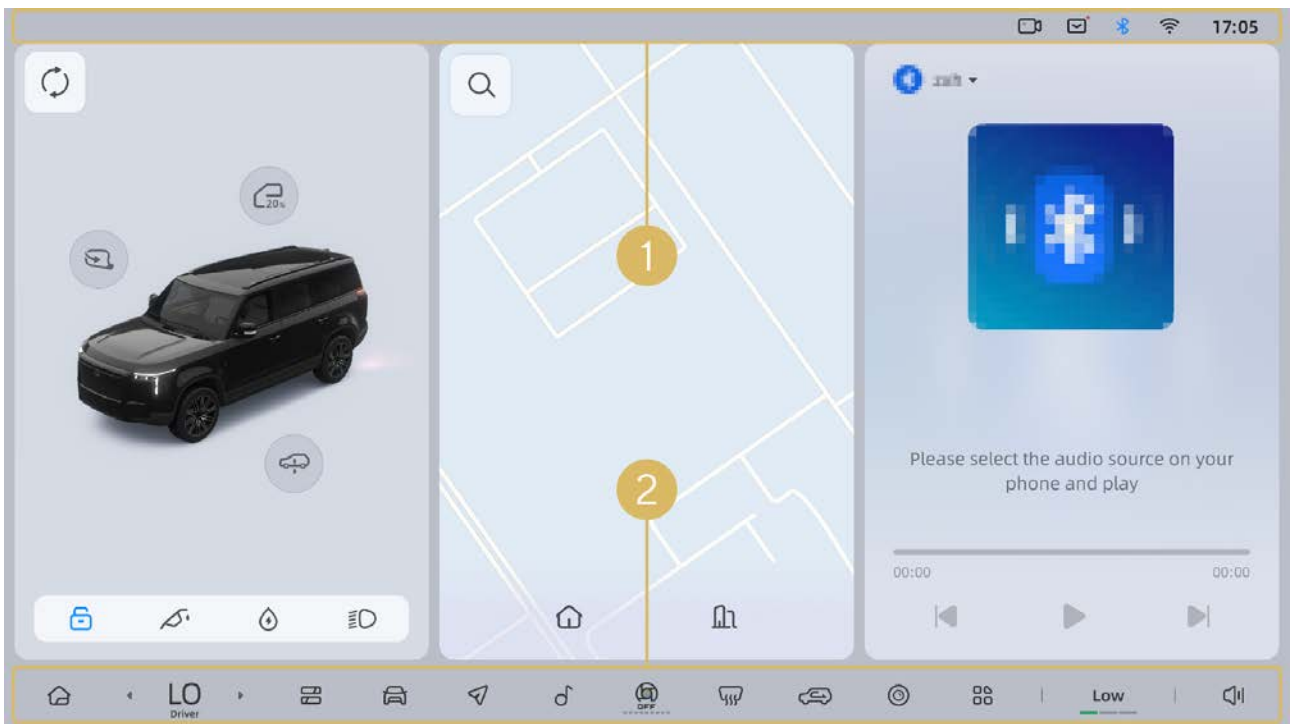

I. Status bar

The status bar displays information such as time, network signal, driver account, Bluetooth connection status, and call status.

II. Bottom function bar

1	Home page	Click to return to the main interface of the central control screen; Long press to edit the main interface.
2	Adjustment of driver's air conditioning	Click the left and right arrows to adjust the air conditioner temperature.

5 Information display

3	Control center	Integrate the frequently used function keys into the control center, and support custom layout to provide you with a more convenient control experience.
4	Vehicle setting	Enter the vehicle settings to set the lights, door locks, driving modes, etc.
5	Map and navigation	Enter the map and navigation to search and view detailed navigation information.
6	Multimedia	Click to enter the app to play, pause, and switch music.
7	A/C control	Click to enter the A/C system control interface.
8030.0	Windshield defogging	Turn on the front windshield defogging system. Click again to turn off the front windshields defogging system.
9	Internal and external circulation	Click to switch the current air conditioning circulation mode, and you can switch between internal circulation, external circulation and automatic circulation modes.
10	Around view monitoring	Click to enter the panoramic image control interface and you can view a panoramic view of the vehicle's surroundings, including front, rear and both sides of the field of view.
11	Application center	Click to enter the application center to view and use all the applications.
12	Energy recovery	Energy recovery levels can be set, including low, medium, high, and intelligent recovery modes.
13	Volume control	After clicking, you can adjust the volume of the audio currently playing in the system.

5 Information display

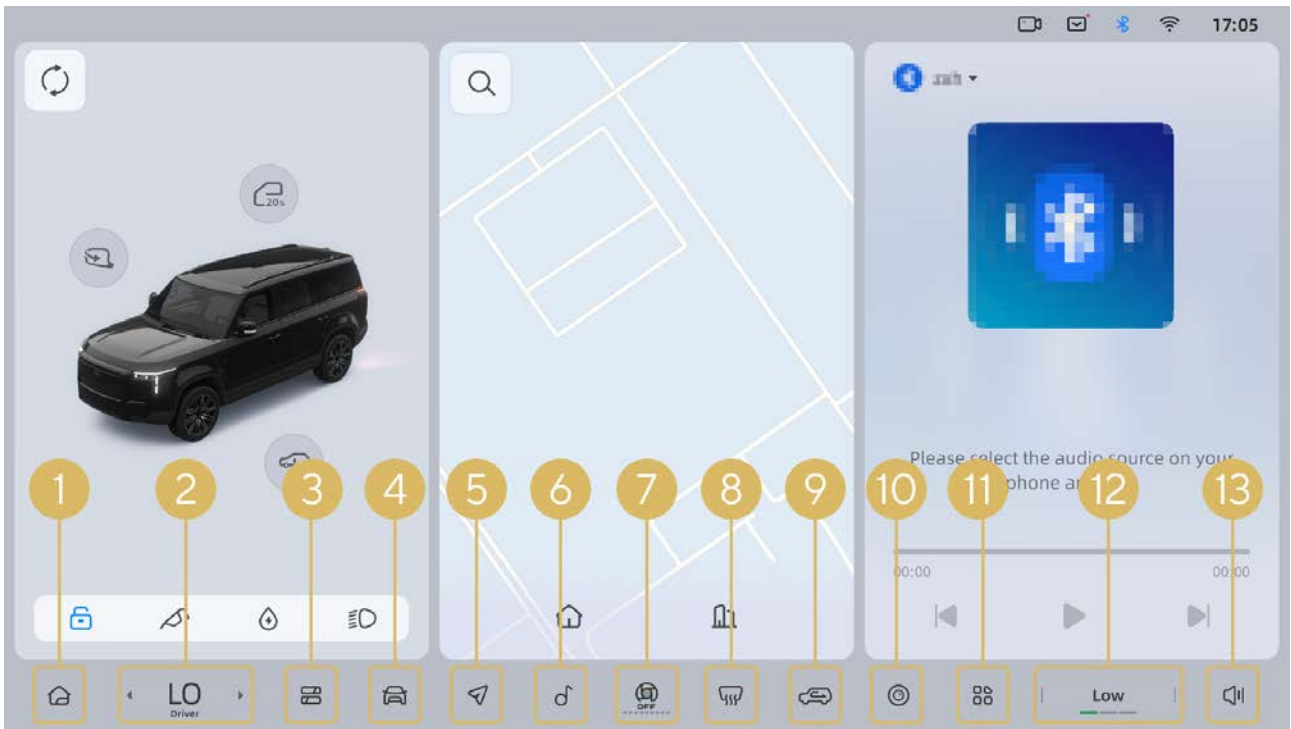

5.1.2.2 Control center

Integrate the frequently used function keys into the control center, and support custom layout to provide you with a more convenient control experience.

I . Use the quick switch

Click on the function bar at the bottom of the central control screen to enter the control center.

II . Custom quick switch

Enter the control center, click the edit icon in the upper right corner to drag the quick switch and adjust its position. You can keep or hide the quick switch according to your daily usage needs.

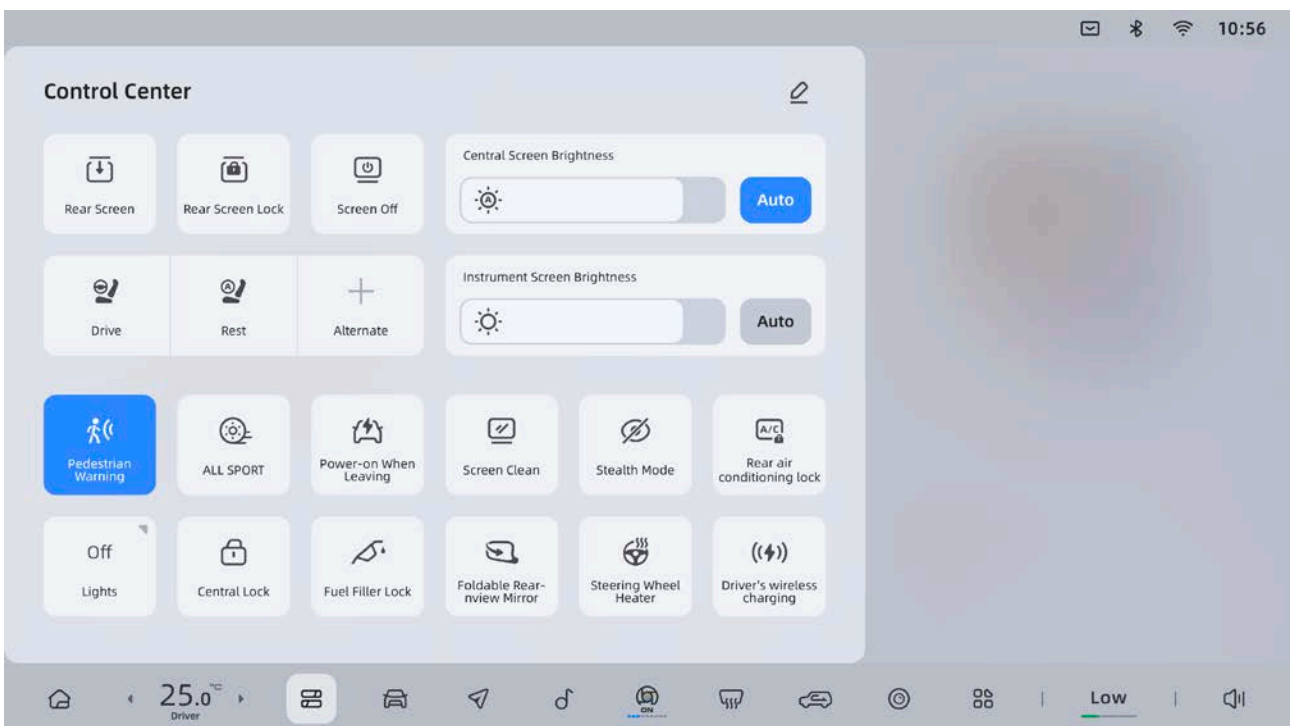

6.1 Key information

6.1.1 Key

This vehicle is equipped with the following keys:

1. Remote key.
2. Mechanical key.

Hint

- Mechanical key is only used for emergency unlocking of car doors. It is recommended to keep it properly and not leave it in the car; If lost, please contact ROX Service Center.

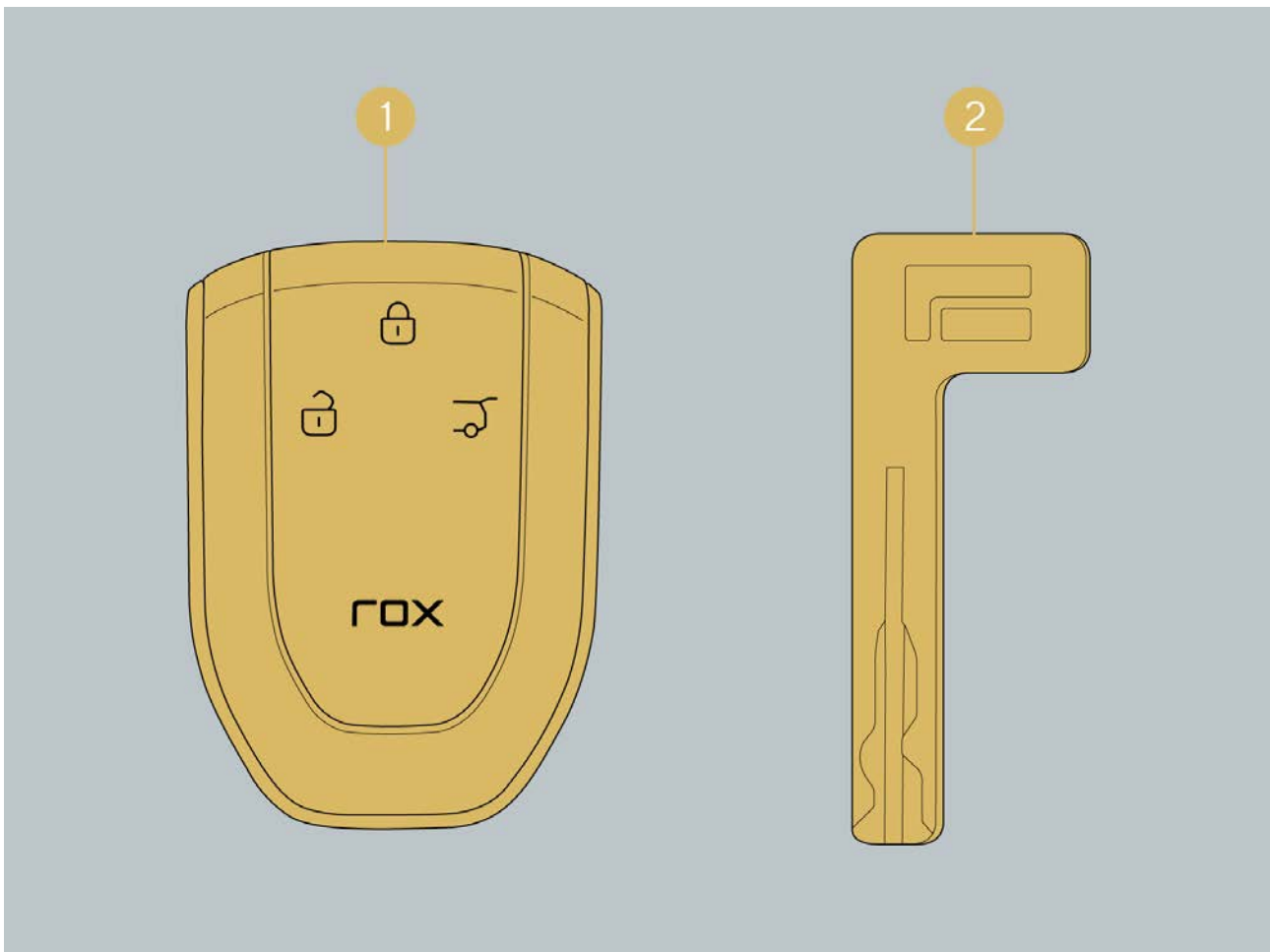

6 Operation

6.1.2 Remote-control key

I. Remote key

1. Unlock button.
2. Locking button.
3. Trunk door control button.

Caution

- When getting out of the car, please carry all the remote keys with you. Otherwise the remote keys may be locked in the car by mistake.
- The remote key is affected by electronic equipment (such as mobile phones, computers, etc.), magnetic substances, and the electromagnetic environment around the vehicle. The key signal may be interfered, resulting in temporary failure of the key function or unstable operation.
- The remote control key is an electronic component. Prevent it from knocking, disassembling or placing in high temperature, humidity and strong vibration environment.
- Do not leave the remote key in the vehicle. It may not be locked in the car by mistake.
- Do not place the remote key in the trunk. It may indicate that the fob cannot be found and cause the vehicle to fail to start.

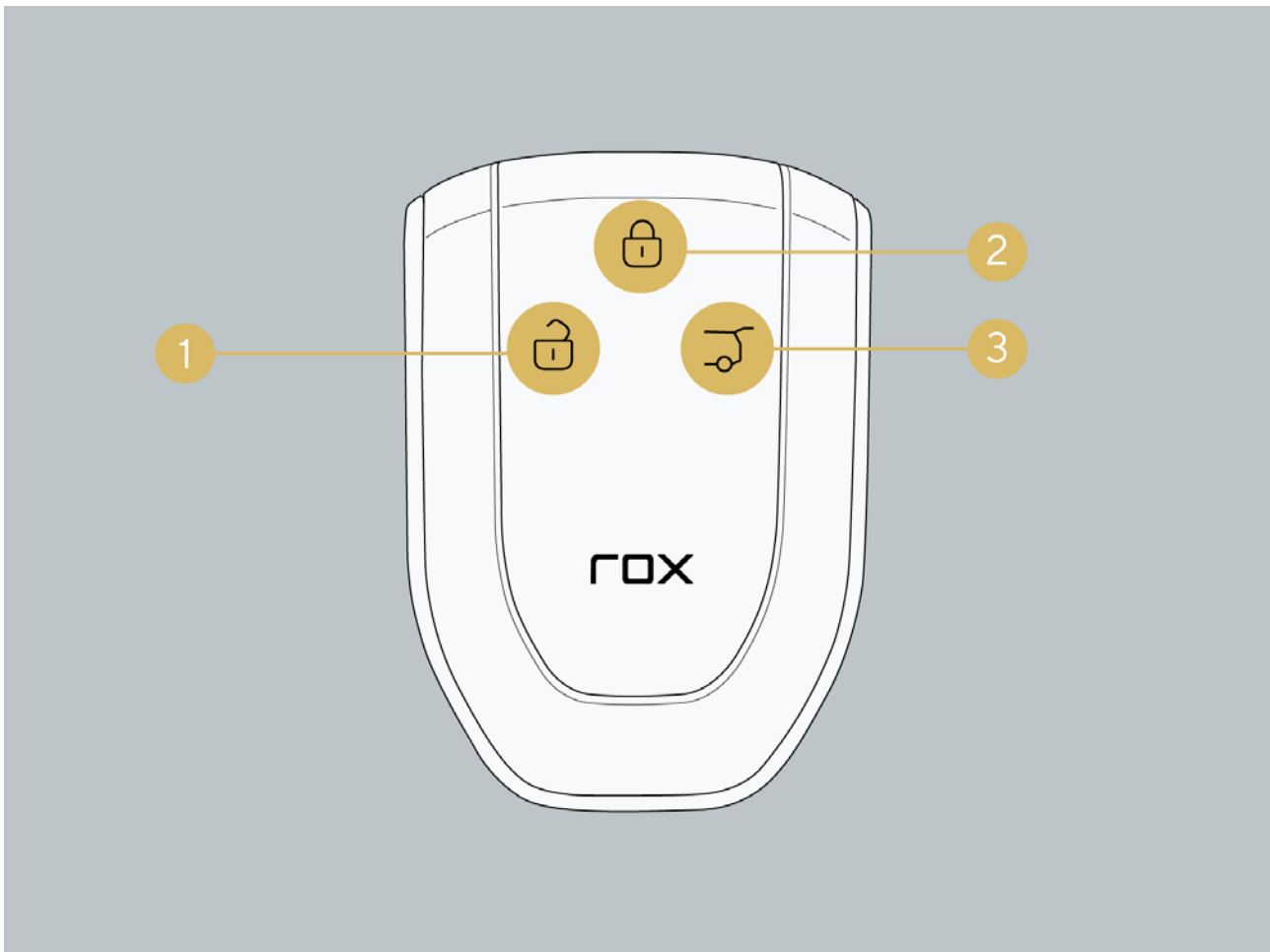

II. Car locating

Activate the car locating function, press the lock button twice continuously in 2 s within the effective range, the turn signal lamp and low beam flash, and the vehicle honks. During the process of locating the car and honking the horn, unlock the vehicle to stop locating. Activate/deactivate the car locating system through the central control screen.

III. Door ajar reminder

When the vehicle is locked, if any door, tailgate, engine hood or fuel filler cap is not closed, the horn will sound alarms.

VI. Depletion of remote battery power

If the battery power of the remote key is low, the instrument screen will display a prompt message of "low key power".

Even if the key is not used, the remote key battery will be depleted. The key power may be depleted. If necessary, please replace the remote key battery if:

- The vehicle cannot start or the remote key function cannot be used normally, or
- Detection area becomes smaller

6 Operation

V. Electromagnetic interference

The remote key receives strong electromagnetic waves for a long time. It is likely to cause the rapid depletion of the battery power. Do not place it near an electrical device that can create a magnetic field, such as:

- TV sets.
- PCs.
- Mobile phones and chargers.
- Table lamps.
- Electromagnetic ovens.

Warning

- Do not place the remote control battery near electrical equipment that can generate magnetic fields for a long time, such as computers, electromagnetic ovens, TV sets, etc.
- Do not expose the remote key to high or low temperature for a long time.
- Do not place the remote key near or in contact with metal or magnetic materials.
- Do not change or increase the transmission power of the antenna without authorization.
- Do not connect external antennas or use other antennas without authorization.
- Do not disassemble the remote key without authorization.

6.1.3 Keyless entry and start system

I. Keyless entry

Unlock or lock the door with the remote key.

II. Keyless start

Carry the remote key, depress the brake pedal, and the "READY" indicator on the instrument screen is on. At this time, the vehicle is drivable.

III. Antenna position (subject to the real vehicle)

S/N	Name	S/N	Name
1	Vehicle exterior antenna	2	Vehicle interior antenna

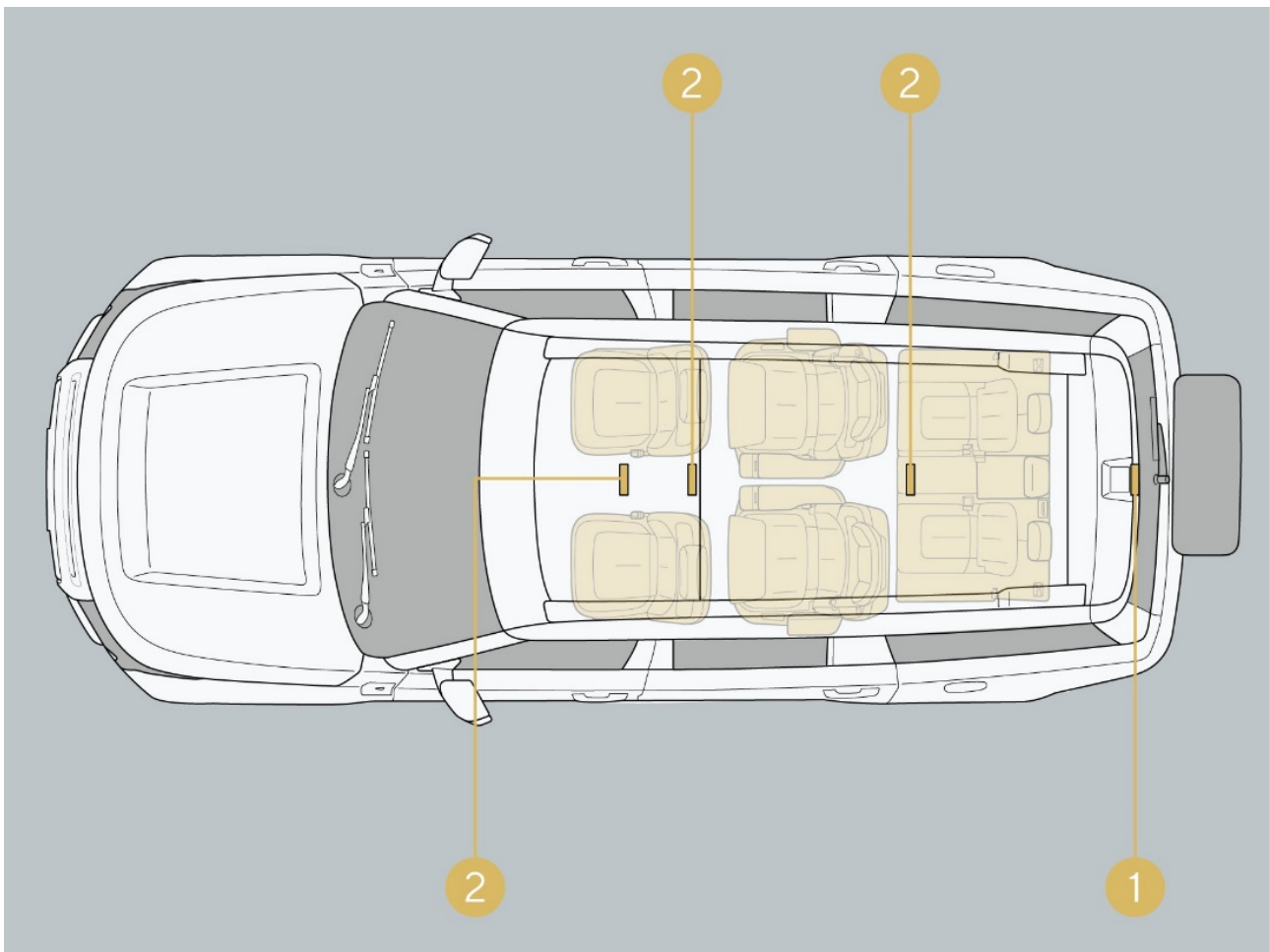

6 Operation

IV. Effective range (area where the remote key can be detected)

1. Start the vehicle

When the remote key is placed in the vehicle, you can start the vehicle.

2. Unlock or lock the door

With the remote key in the valid range, you can unlock/lock any side door (only the door where the key is detected can be operated).

3. Welcome function

With the remote key in the effective range, the welcome function can be triggered. The vehicle will make corresponding welcome actions according to the content set by the user.

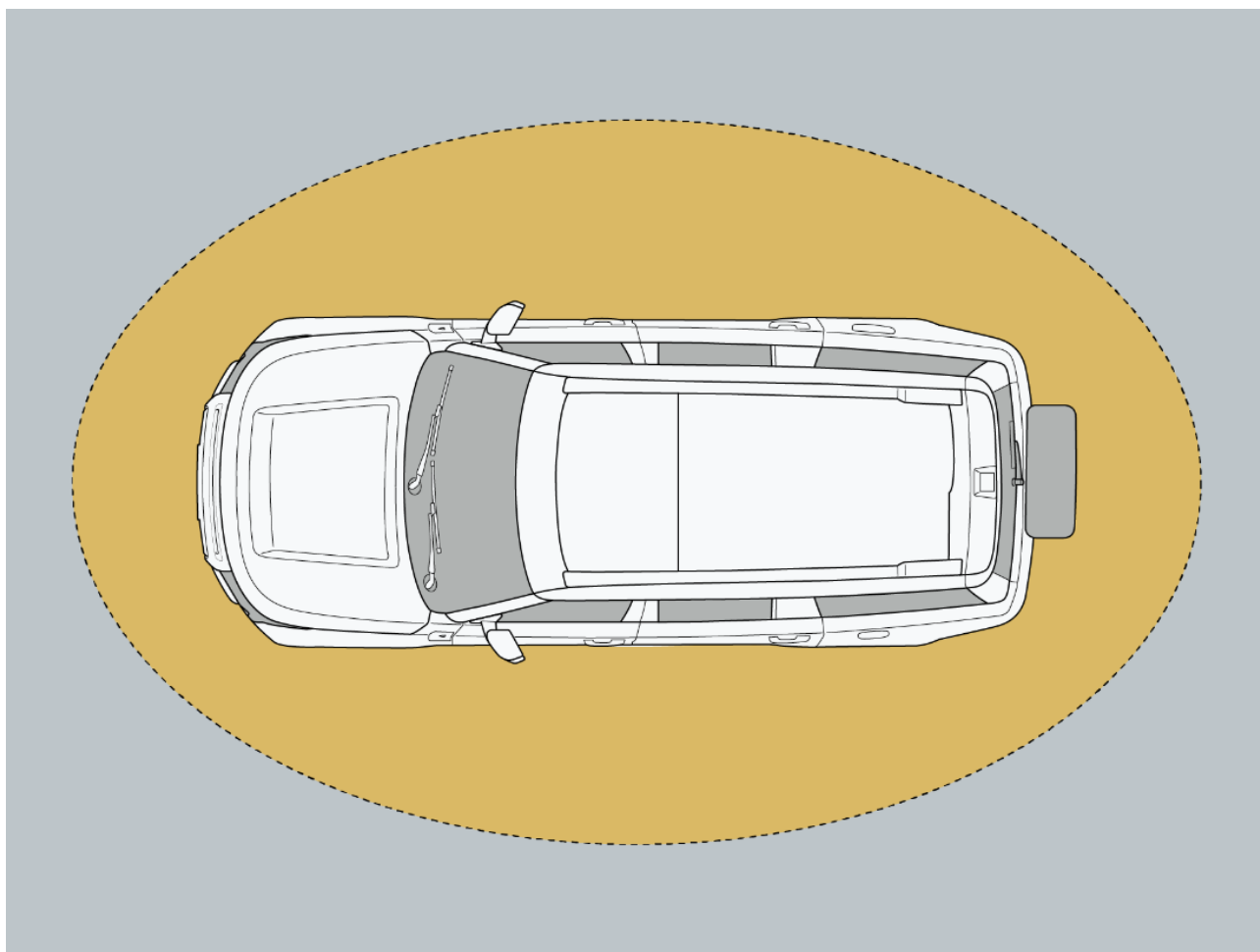

4. Open trunk door

With the remote key in the effective range of the external antenna at the trunk door, press the trunk door unlock button with the remote key to release the electricity and manually open the trunk door.

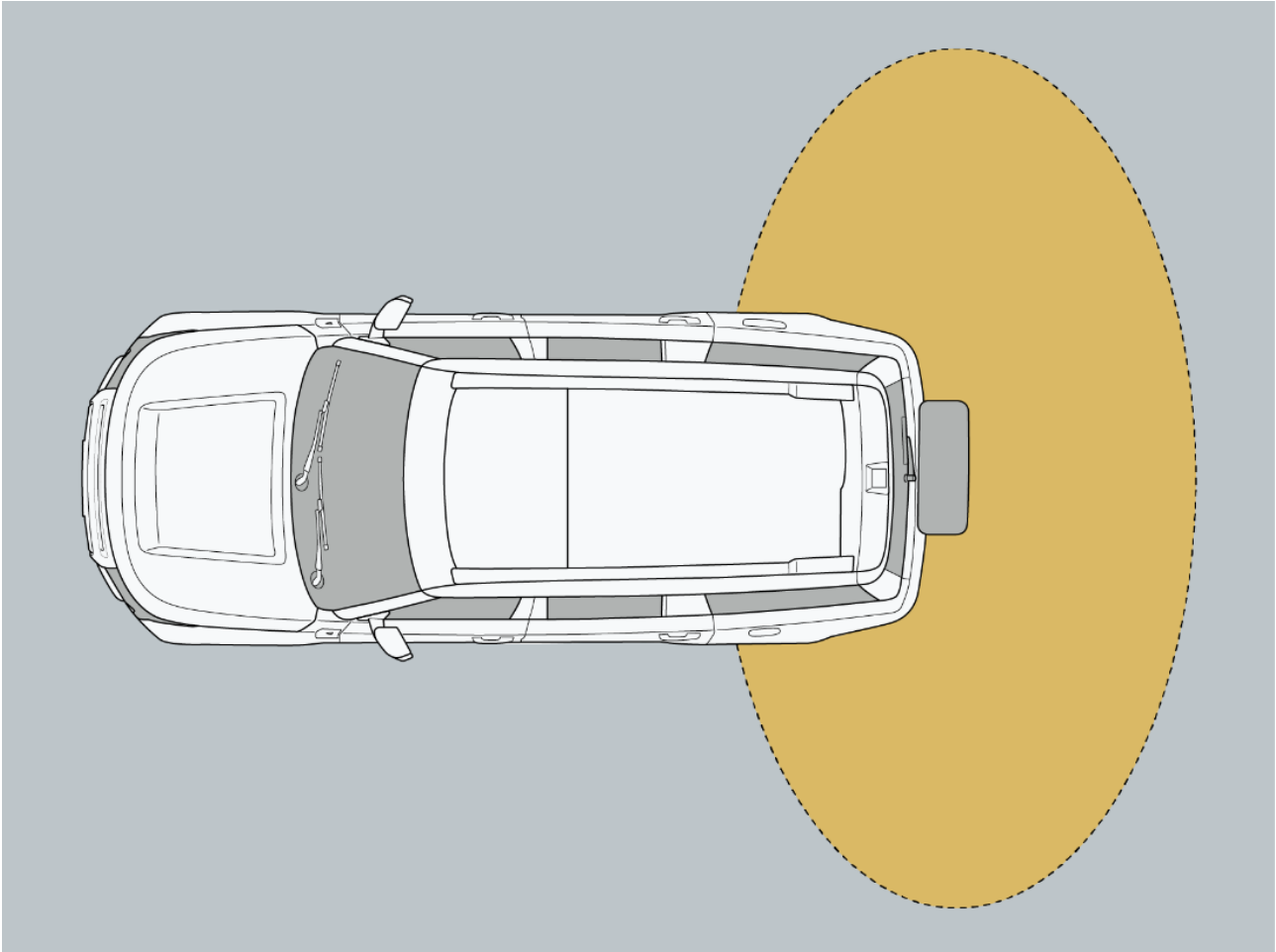

V. Conditions affecting use

Communication between the remote key and the vehicle may be affected, thereby hampering the keyless entry function, the keyless start system, the remote key and the anti-theft system if:

- The remote key is in contact with or covered by metal objects.
- The remote battery power is depleted.
- The remote key is exposed to high or low temperature for a long time.
- The remote key is placed near the battery, charger, or other electronic device.
- It is close to television towers, power plants, petrol stations, radio stations, airports or other facilities that generate strong radio waves.
- The remote key is placed with a magnetic card (e.g. bus card, bank card, etc.).
- A film or metal object containing metal components is adhered to the window.
- Use other remote key near the vehicle.

6 Operation

VI. Precautions for keyless entry

- Anyone can unlock/lock any door as long as the remote key is in the valid range. However, only doors with a detected remote key can be used to unlock/lock the vehicle.
- If the inductive sensor contact with ice, snow, mud, etc., it may not work properly. Please clean the sensor, and try to unlock or lock the door again.
- If there is another remote key in the detection area, it may delay unlocking/locking the vehicle.
- When the remote key is in the valid range, it may also unlock/lock the door if there is a large amount of water splashing on the door handle (such as raining or washing car).
- If you touch the door handle sensor while wearing gloves, the unlock/lock operation may be delayed or blocked.

VII. Remote key failure

Unlock/ lock the door with the mechanic key.

VIII. Parking vehicle for a long time

Do not place the remote key close to the vehicle to avoid theft of the vehicle.

6.2 Opening, closing and locking door

6.2.1 Door

I. Open and close the door

1. Open/close the door from outside

Open: After the vehicle is unlocked, pull the outside door handle to open the door.

Close: Push the door towards the inside of the vehicle until it is about to close, and the door will automatically close.

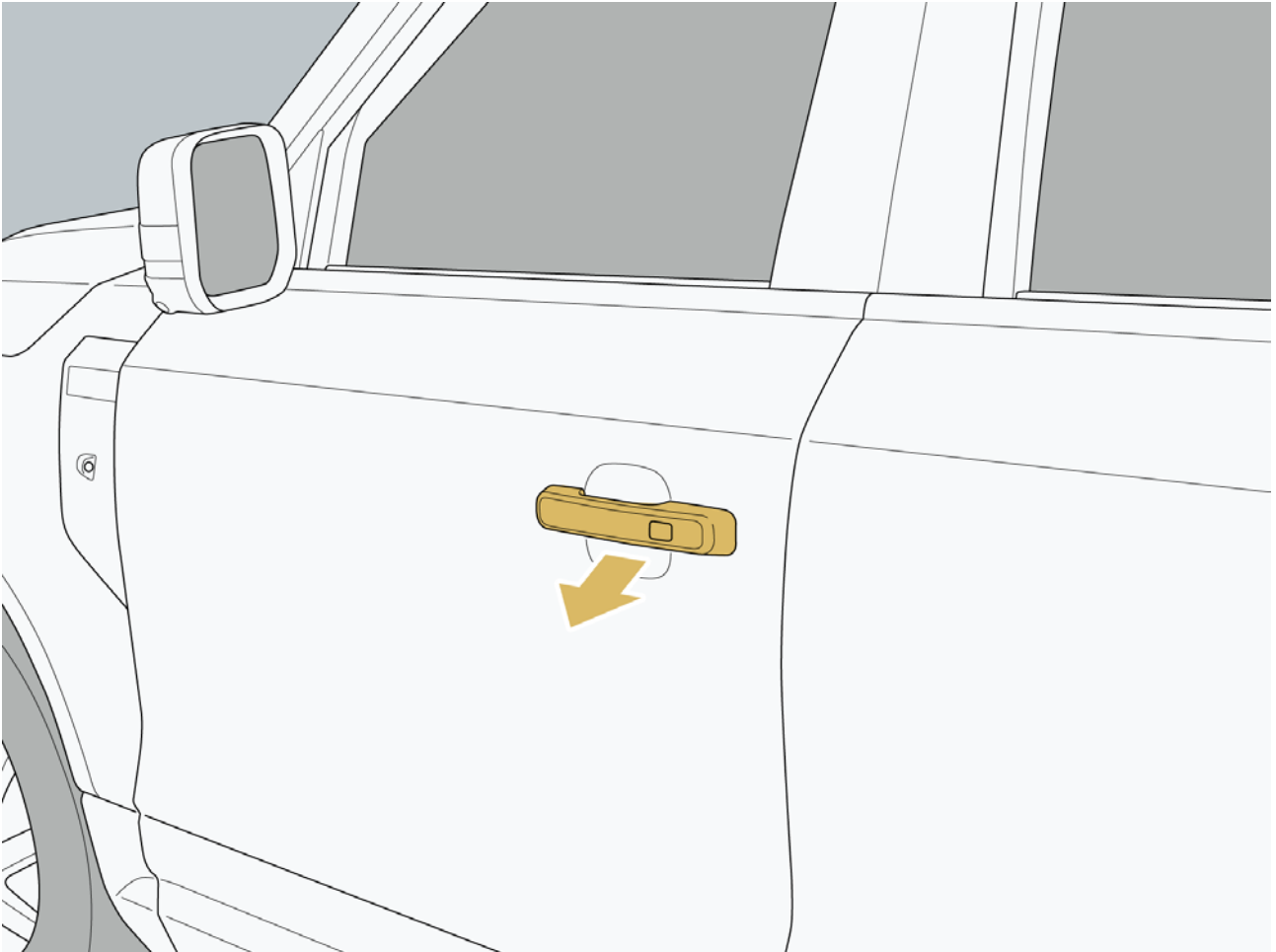

6 Operation

2. Open/close the door from inside

Open: When the door is unlocked, pull the inside door handle to push outward to open the door.

Close: Pull the door until it is about to close, and the door will automatically close.

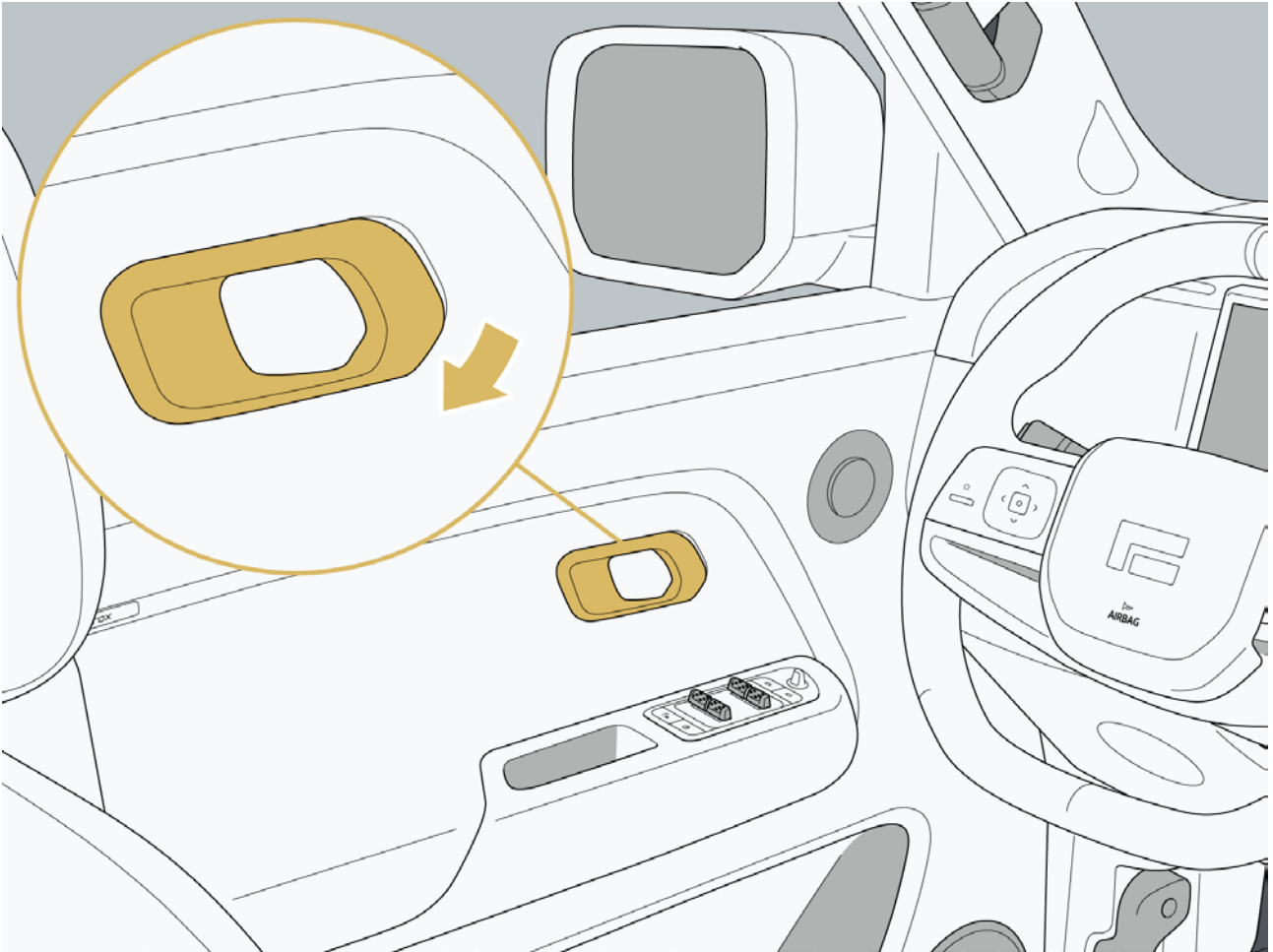

II. Unlock/lock the door

When the door is unlocked from outside, the exterior rearview mirror automatically unfolds.

When the door is locked from outside, the exterior rearview mirror automatically folds.

1. Unlock/ lock the door with the remote key

Unlock: When the vehicle is in a locked state, press the remote key unlock button 1 within the effective range to unlock all doors.

Lock: When the vehicle is in an unlocked state and all doors, hood and trunk doors are closed, press the remote key lock button 2 within the effective range to lock all doors.

Hint

- When the vehicle power is in "READY" mode, the remote key unlock/lock door function will not work.

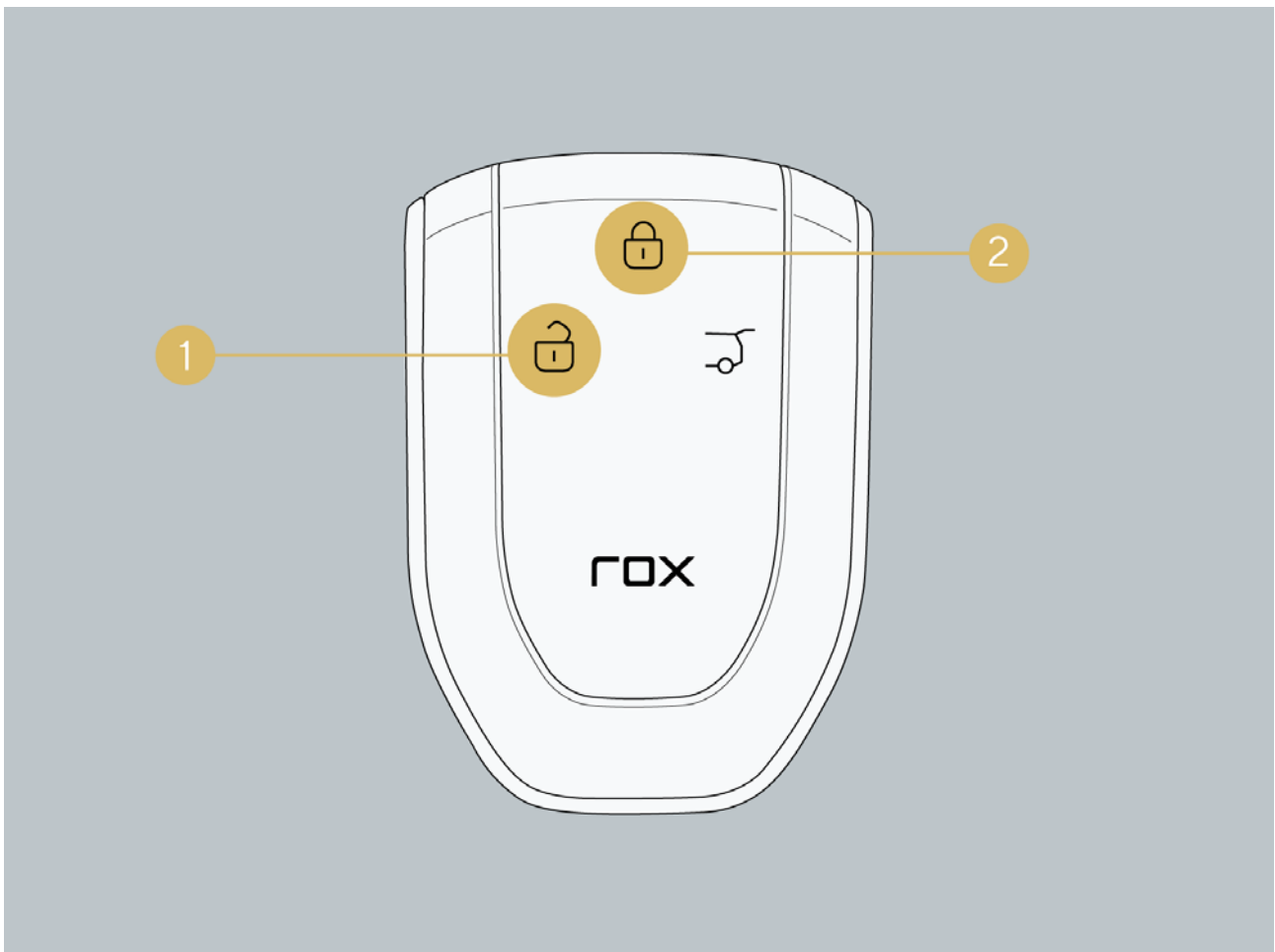

6 Operation

2. Unlock/ lock the door by keyless entry

Unlock the door:

- When the central control screen is set to only unlock the driver, press the unlocking area on the inner surface of the driver's side door handle with carrying the remote key or Bluetooth key, to unlock the driver's side door. Touch the unlocking area on the inner surface of the driver's side outer handle to unlock the whole car. Press the unlocking area on the inner side of other door handle with carrying the remote key or Bluetooth key to unlock the whole car.
- When the central control screen is set to unlock the whole car, press the unlocking area inside the door handle on either side the remote control key or Bluetooth key to unlock the whole car.

Lock the door: When the vehicle is in an unlocked state and all doors, hood and trunk doors are closed, press the outside door handle sensor area with the Bluetooth key or remote key to lock all doors.

Hint

- If the remote key is in the car, the door cannot be unlocked/locked by touching the door handle sensor area.

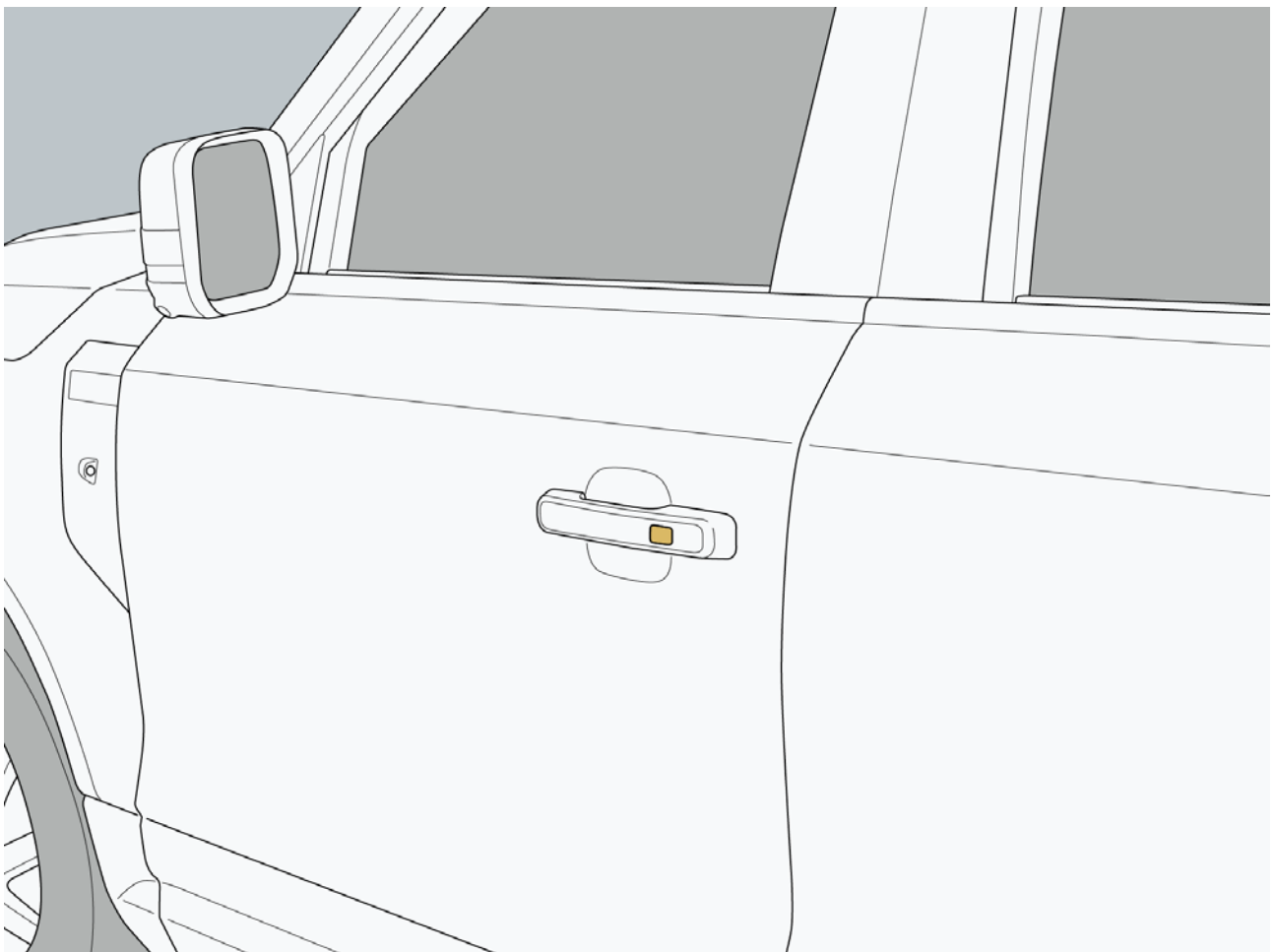

3. Unlock the door when approaching/lock the door when leaving

Click "Vehicle Settings → Vehicle → Door/Window Lock → Auto-Lock When Leaving" through the central control screen, to set the activation and deactivation of unlock door when approaching/lock door when leaving.

Unlock: With the vehicle locked, approach the vehicle with carrying the remote key or Bluetooth key. All doors are unlocked automatically.

Lock: When the vehicle is in an unlocked state and all doors, hood and trunk door are closed, all doors are locked automatically after leaving the vehicle for more than a certain distance with carrying the remote key or Bluetooth key.

Hint

- If either door is not properly closed, there is a remote key in the car, the seat is occupied, or the camping mode is enabled, the locking after leaving function will not work.
- In order to prevent the power of the key battery from being continuously consumed, after the vehicle is locked for 7 days, the function of unlocking the door when approaching the vehicle/locking the door when leaving the vehicle will be turned off, and the vehicle needs to be unlocked/locked manually.
- To ensure the safety of your vehicle and personal belongings, please make sure the vehicle is locked before leaving.

6 Operation

4. Unlock or lock the door with unlocking/locking button

Unlock: When doors are locked, press the unlock button to unlock all doors.

Lock: When all doors are closed and in the unlocked state, press the unlock button to lock all doors.

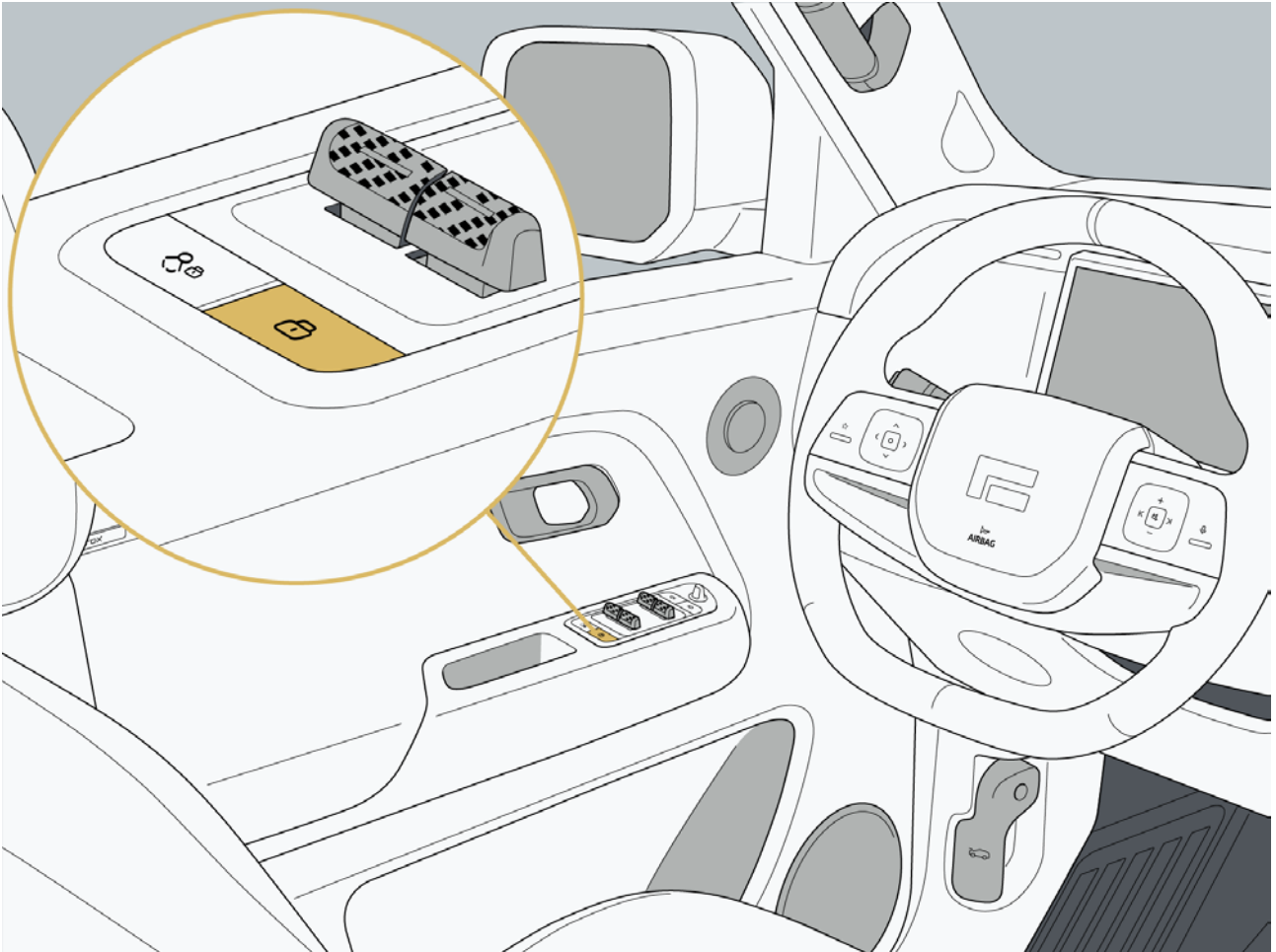

5. Unlock/ lock the door with central control screen

Unlock: When doors are locked, click the door lock icon on the control screen to unlock all doors.

Lock: When all doors are closed and in the unlocked state, click the door lock icon on the control screen to lock all doors.

6. Auto-unlock for parking

All doors will unlock when they are locked and the vehicle is shifted to P from other gears.

7. Auto re-locking

After unlocking the door from outside if no door or trunk door is opened within 30 s, the door will be automatically re-locked.

8. Auto-lock during driving

When the vehicle is unlocked and both the doors and the trunk are closed, and the driving speed is $\geq 15\text{km/h}$, the vehicle will automatically lock.

9. Auto-unlock due to collision

The complete vehicle power is in "READY" or "ON" mode. When the vehicle suffered a serious collision, all doors will be automatically unlocked and the hazard warning lamp will be on.

III. Emergency unlocking and locking door

When the door cannot be unlocked/locked with the remote key or keyless entry, the driver door can be unlocked/locked with the mechanical key.

1. Pull the door handle outward.

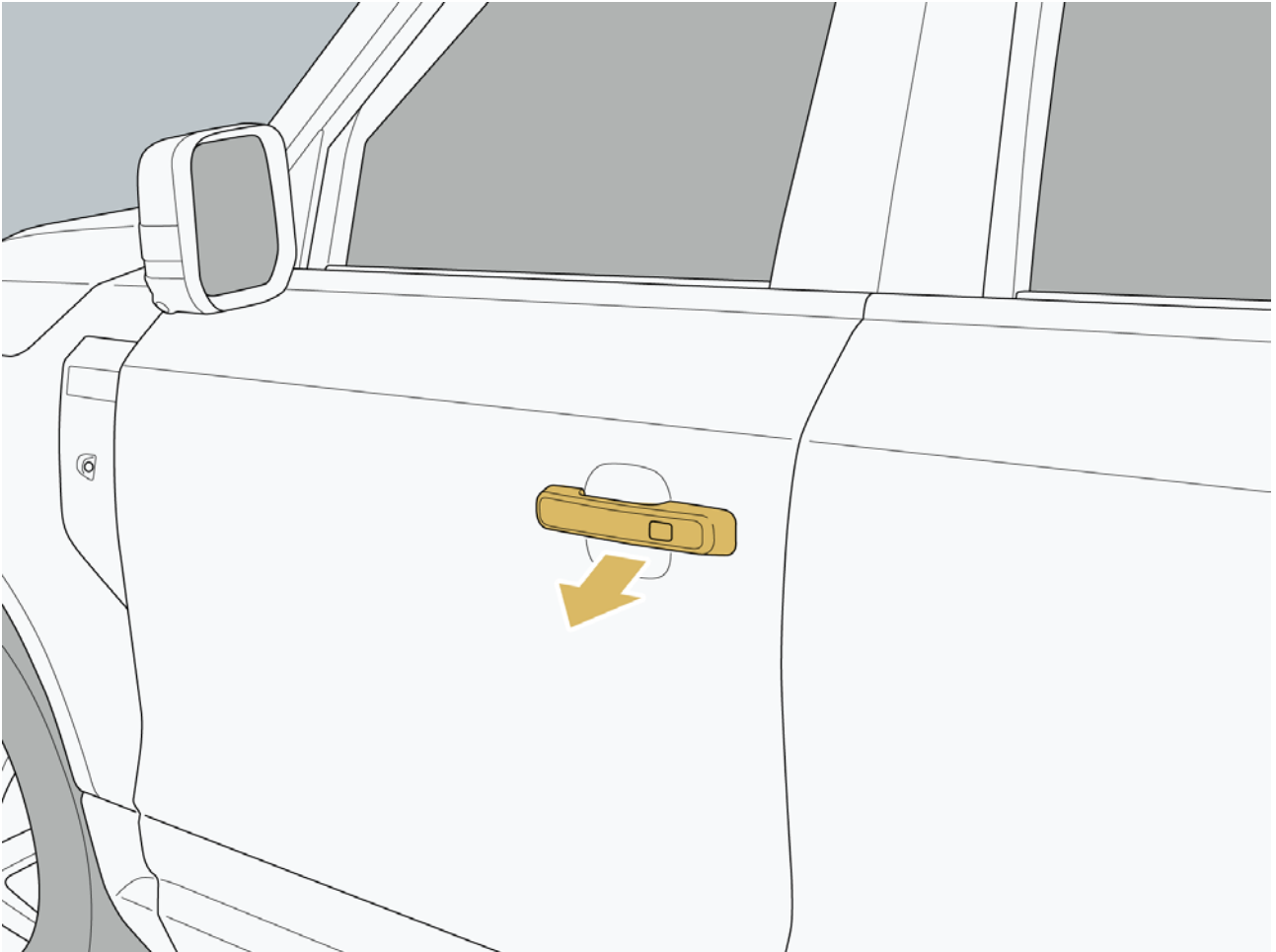

6 Operation

2. Insert a mechanical key into the keyhole and turn the key:

- Unlock: Turn the key clockwise to unlock the driver door.
- Lock: When all doors, hood and trunk doors are closed, turn the key lock counterclockwise to lock the driver door.

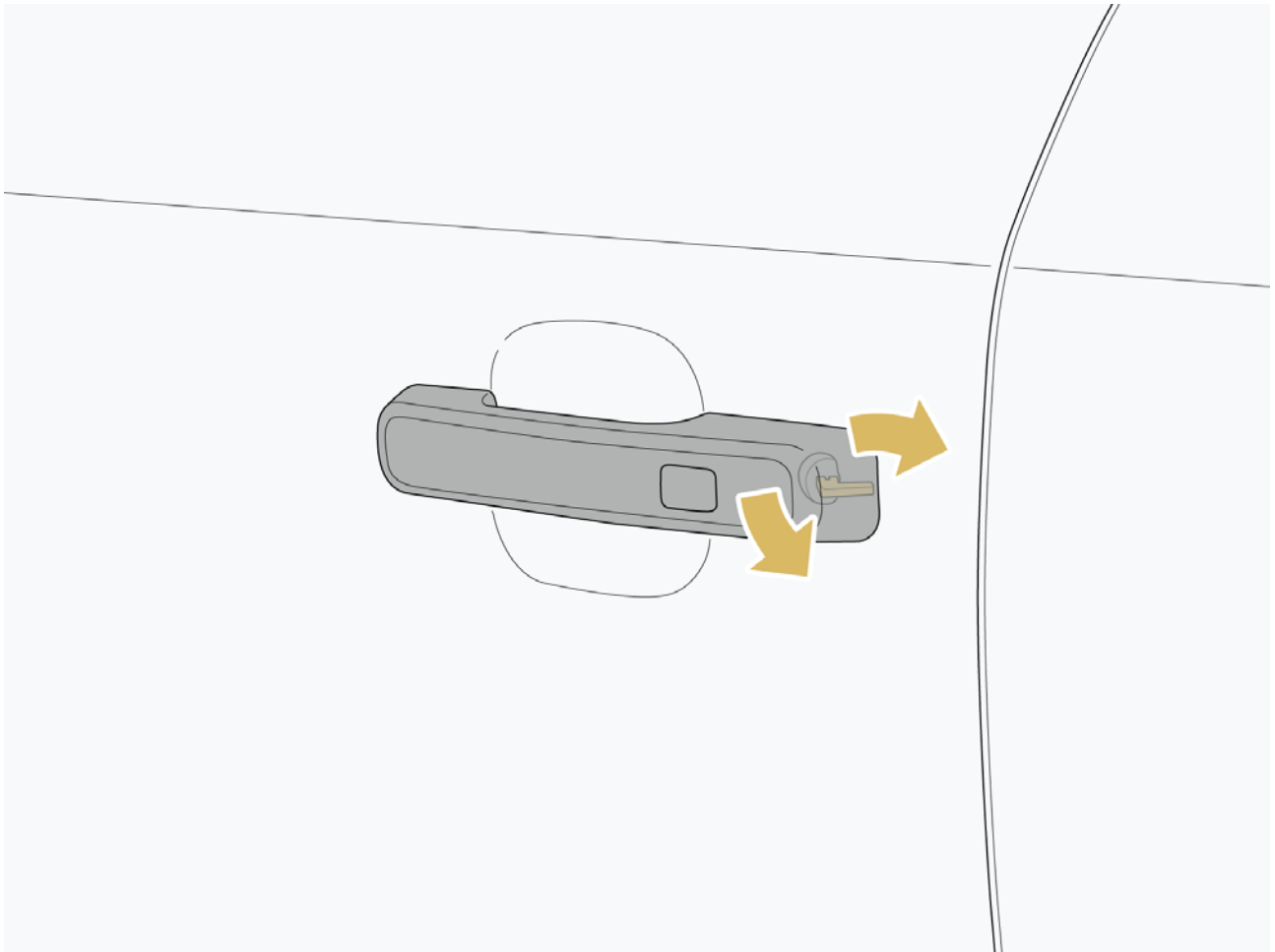

IV. Door lock settings

1. Honk on lock

Click "Vehicle Settings → Vehicle → Door/Window Lock → Lock Whistle" through the central control screen, to set the activation and deactivation of the lock whistle prompt sound.

2. Key unlock method

Click "Vehicle Settings → Vehicle → Door/Window Lock → Key Unlock" through the central control screen, to set the key unlock method:

- Unlock the driver door: When using the remote key to unlock the car, only the driver door can be unlocked.
- Unlock the whole car: Unlock all doors with the remote key.

3. Auto-unlock for parking

Click "Vehicle Settings → Vehicle → Door/Window Lock → Auto-unlock for Parking" through the central control screen, to set the activation and deactivation of the auto-unlock for parking.

4. Unlock the door when approaching/lock the door when leaving

Click "Vehicle Settings → Vehicle → Door/Window Lock → Auto-Lock When Leaving" through the central control screen, to set the activation and deactivation of unlocking when approaching/locking when leaving.

V. Automatic pulling-in

When the door is closed from the fully open state to the half-locked state, it will automatically close to the fully locked state. During the automatic pulling-in process, re-opening the door will stop the door closing action.

To enable/disable the electric suction door function, click the "Vehicle Settings → Vehicle → Door/Window Lock → Electric Suction Door" through the central control screen.

Warning

- Do not open the door while the vehicle is running to avoid accidents.
- Do not unlock the door while driving. Unlocking the door may pose a risk of the occupants being thrown out of the vehicle.
- The electric suction door has no ajar function. When closing the door, do not place your hands on the edge of the door or window, and ensure that there are no other obstacles in the closing path of the door or window to avoid being pinched or damaging the door or window.
- If any object or body part is accidentally caught, please quickly pull the door handle to open the door.
- If the interval between the current automatic pulling-in start time and the last automatic pulling-in start time is less than 8 seconds, the count will be increased by 1. When the abuse count reaches 10 times, the abuse protection will be triggered, and the electric pulling-in function will be stopped for 30 seconds. After 30 seconds, the electric pulling-in function will be automatically restored.
- Before locking the vehicle, make sure there is no one inside and all the windows are closed. Please make sure that the doors and windows are closed before leaving the vehicle.
- Anti-theft system helps to prevent the vehicle from being stolen, but it cannot completely prevent theft. To ensure the safety of the vehicle, please park it in a safe parking area and remove any valuable or personal belongings from the vehicle before leaving.
- Before opening the door, be sure to check whether there are other vehicles or pedestrians on the door-side road.
- Do not leave children or pets in the car alone. Sealed vehicles can get hot. Children or animals can be seriously injured or even killed because they can't escape the vehicle. Children may be harmed by operating vehicle equipment. Children may also suffer other injuries due to intruders entering the car.

6 Operation

6.2.2 Trunk door

I. Unlock the trunk door

1. Trunk door open switch button

Applicable to models without spare tires: Press the trunk door open switch button with carrying the remote key or Bluetooth key to unlock the trunk door.

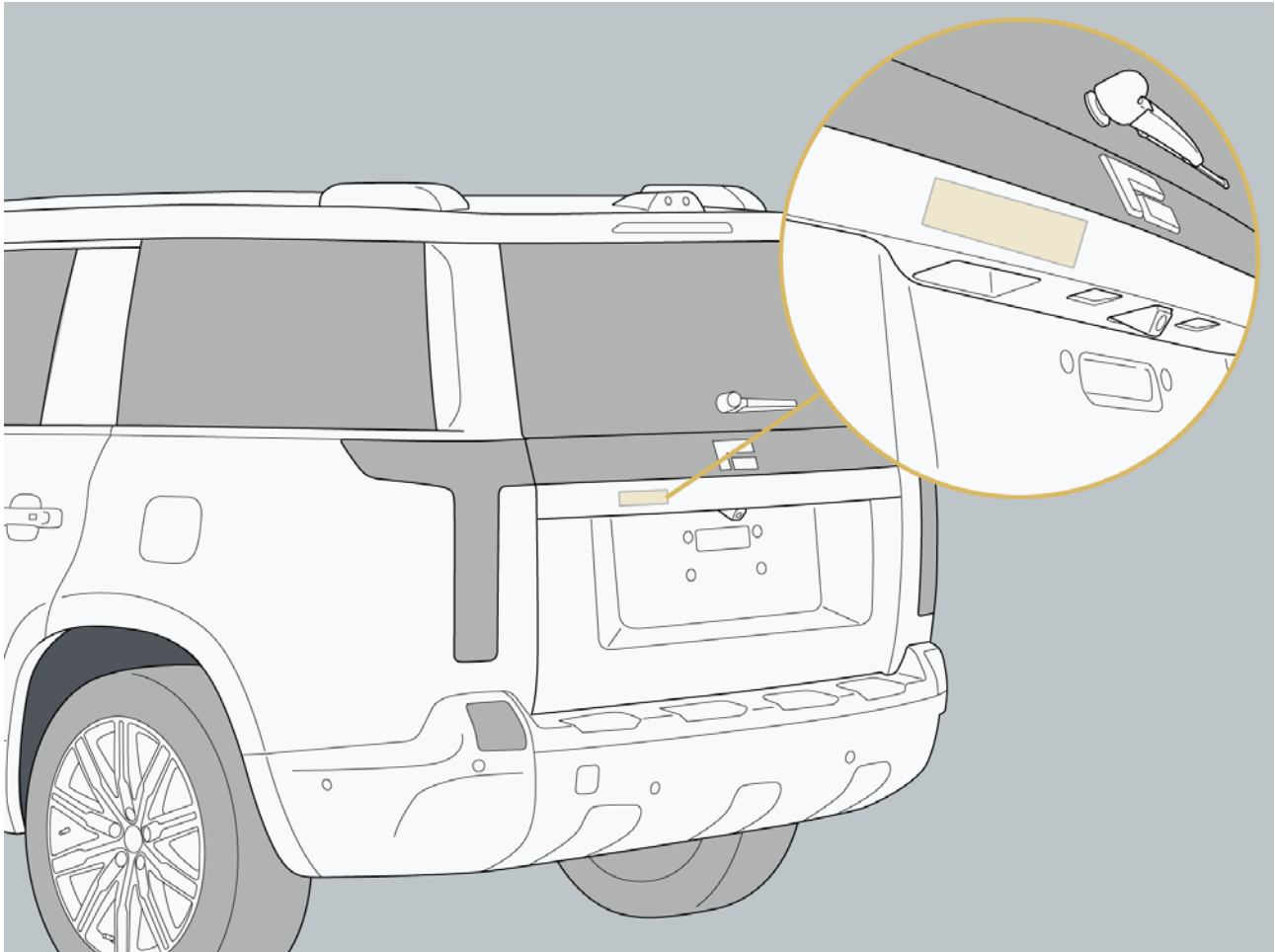

6 Operation

Applicable to models with spare tire: Pull the trunk door to open the switch handle with carrying the remote key or Bluetooth key to unlock the trunk door.

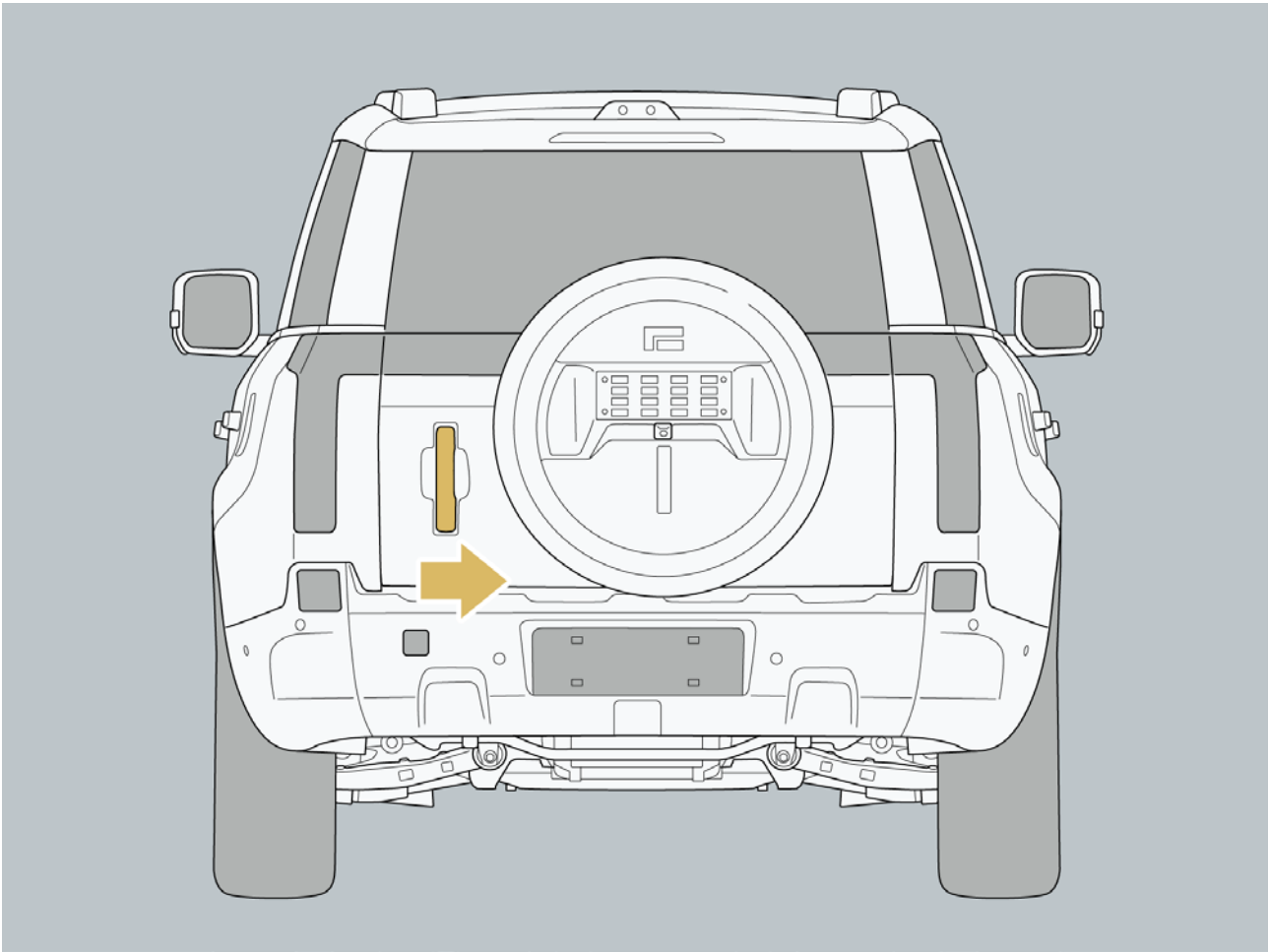

2. Remote key unlocking

Press the remote key unlock button within the effective range to unlock the trunk door.

6 Operation

II. Open the trunk door

Applicable to models without spare tires: When the trunk door is in an unlocked state, press the trunk door open button to open the trunk door.

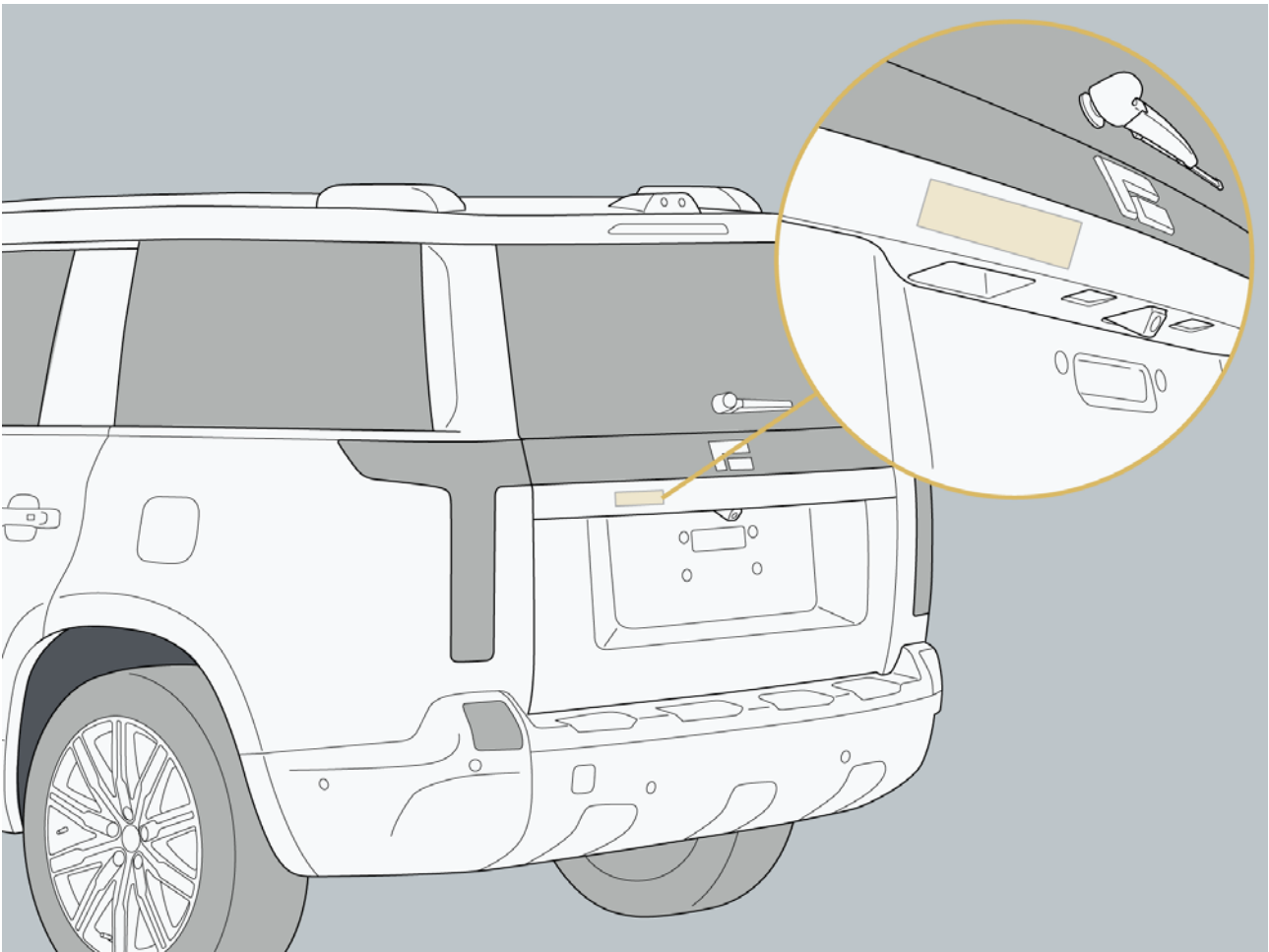

6 Operation

Applicable to models with spare tire: When the trunk door is in an unlocked state, pull the trunk door to open the switch handle to open the trunk door.

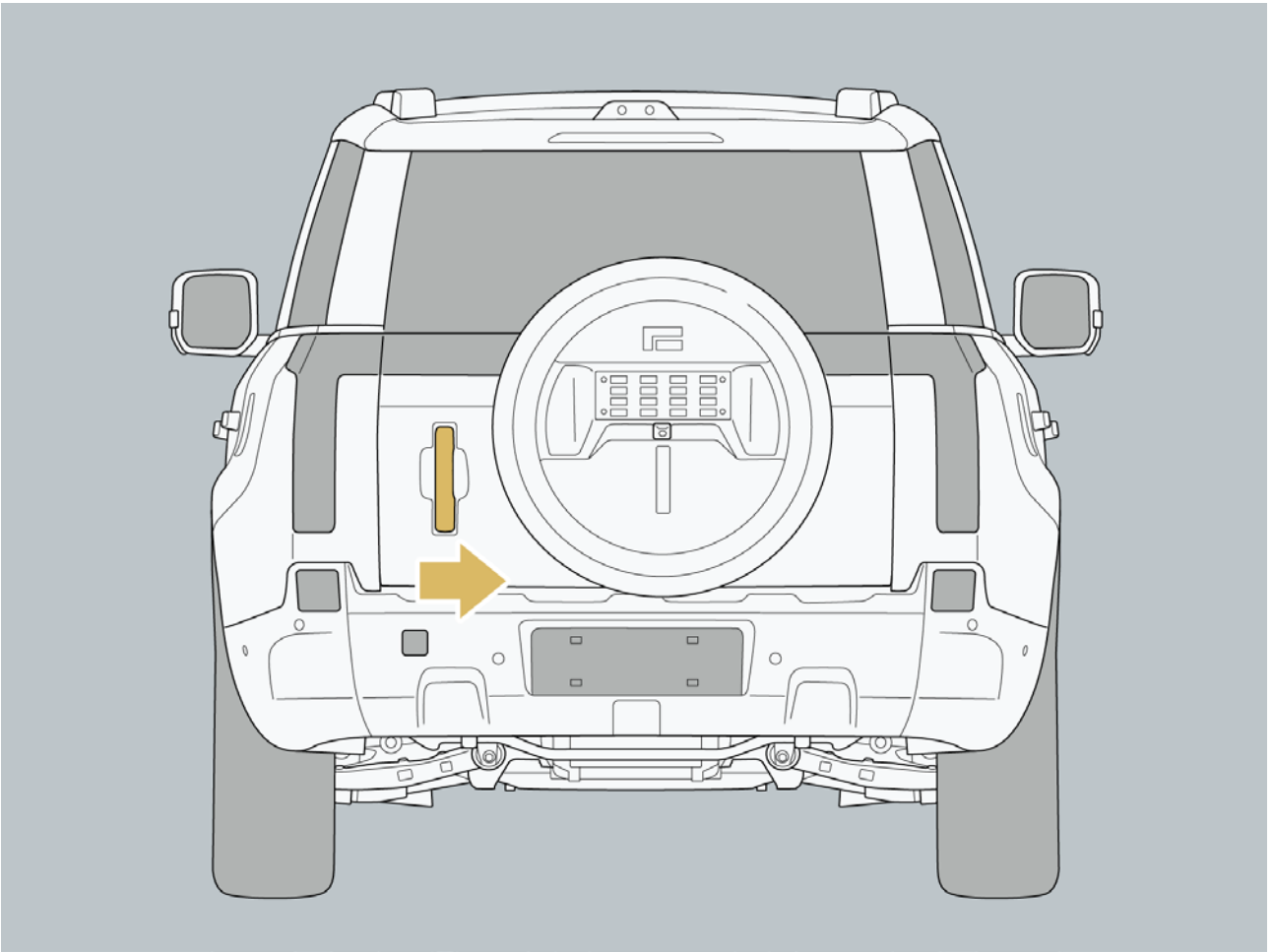

6 Operation

III. Keep the trunk door open

1. Unlock the trunk door opening limiter.
2. Lock the trunk door opening limiter.

The trunk door opening limiter can be operated only when the trunk door is fully opened.

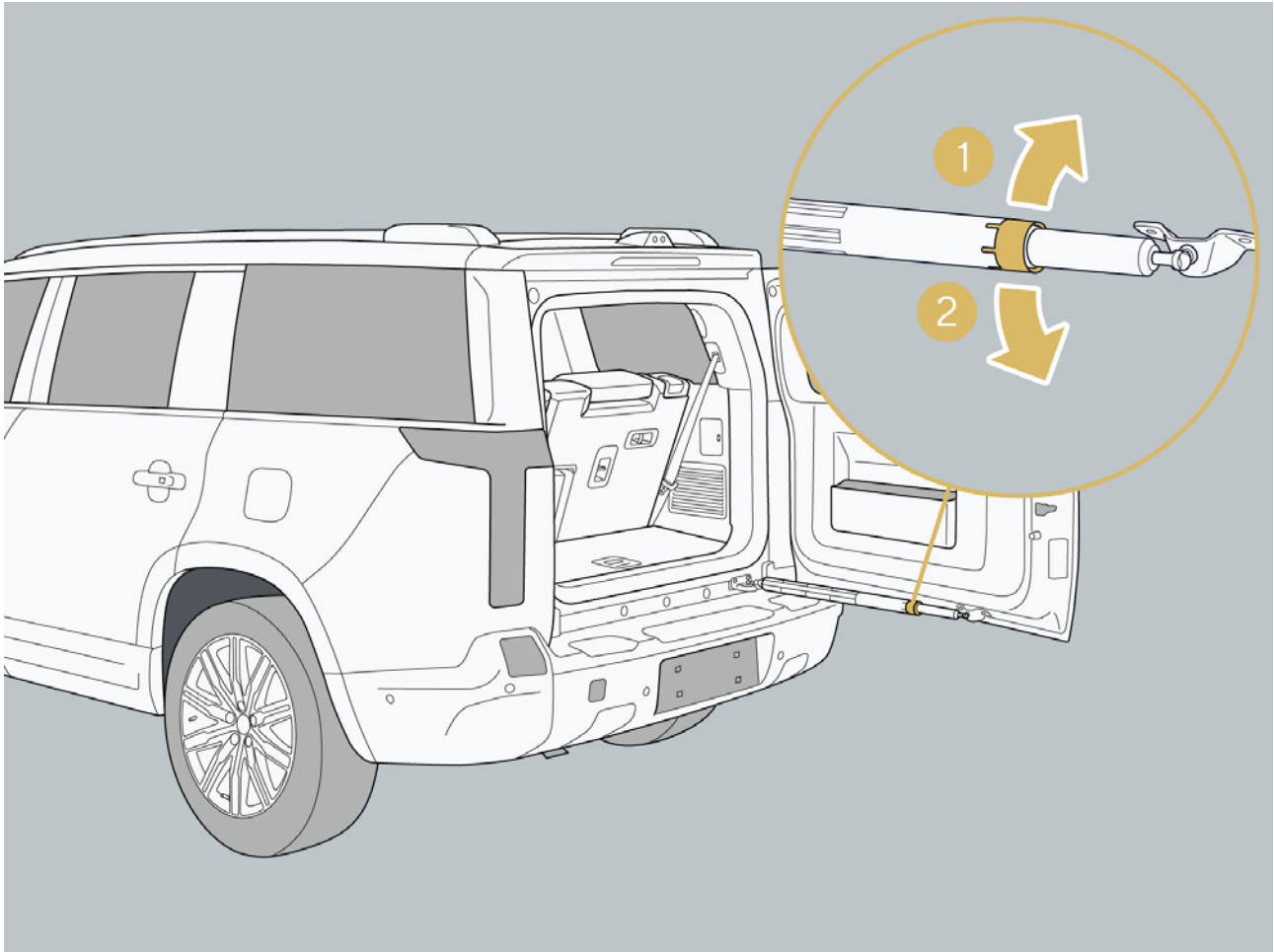

IV. Close the trunk door

Pull the trunk door until it is about to close, and the trunk door will automatically close by suction.

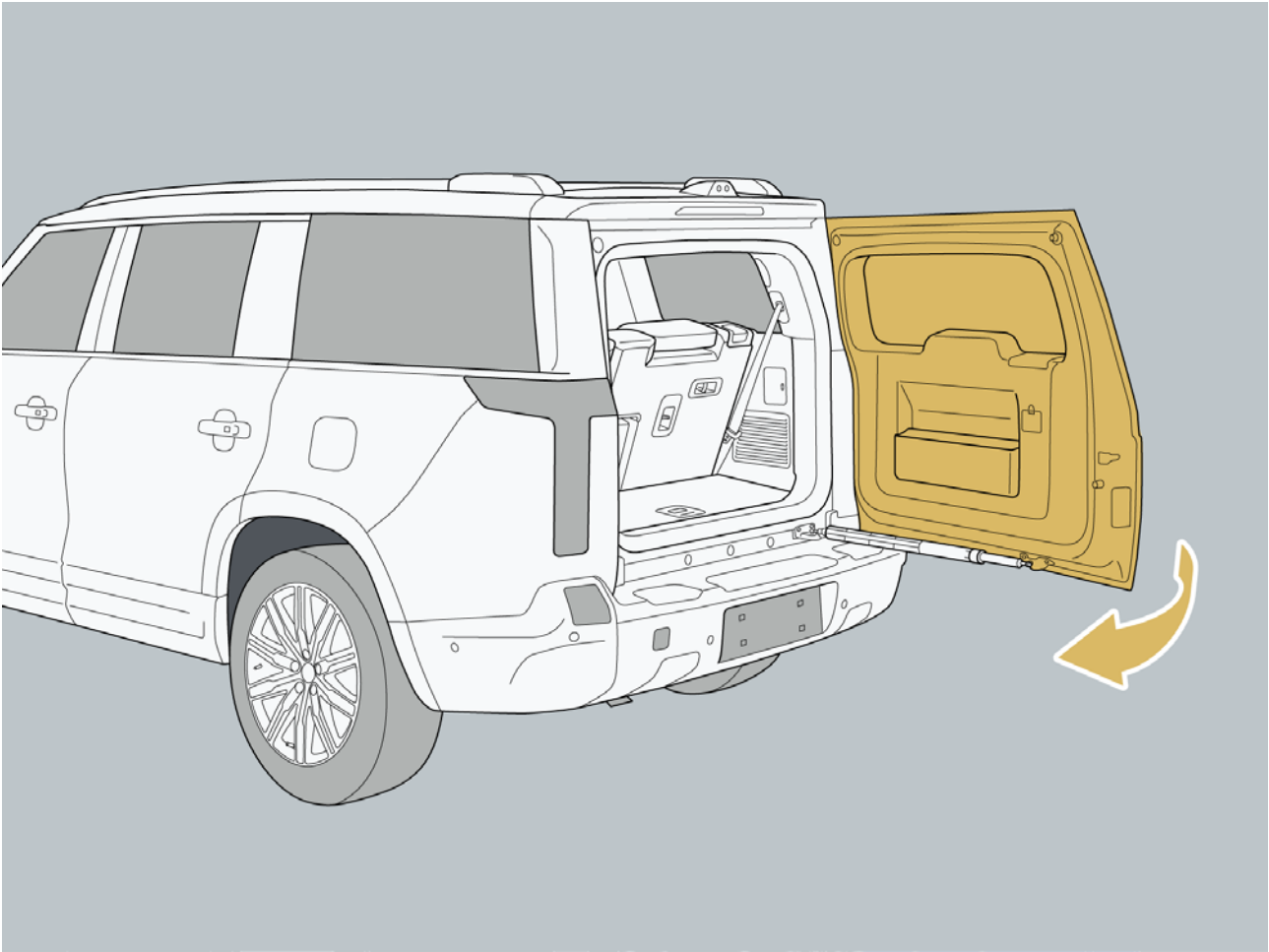

6 Operation

V. Open the trunk door in emergency

In an emergency, you can use mechanical means to open the trunk from inside the vehicle.

1. Enter the trunk.
2. Press the clip on the door lock trim cover to remove the door lock trim cover outward.

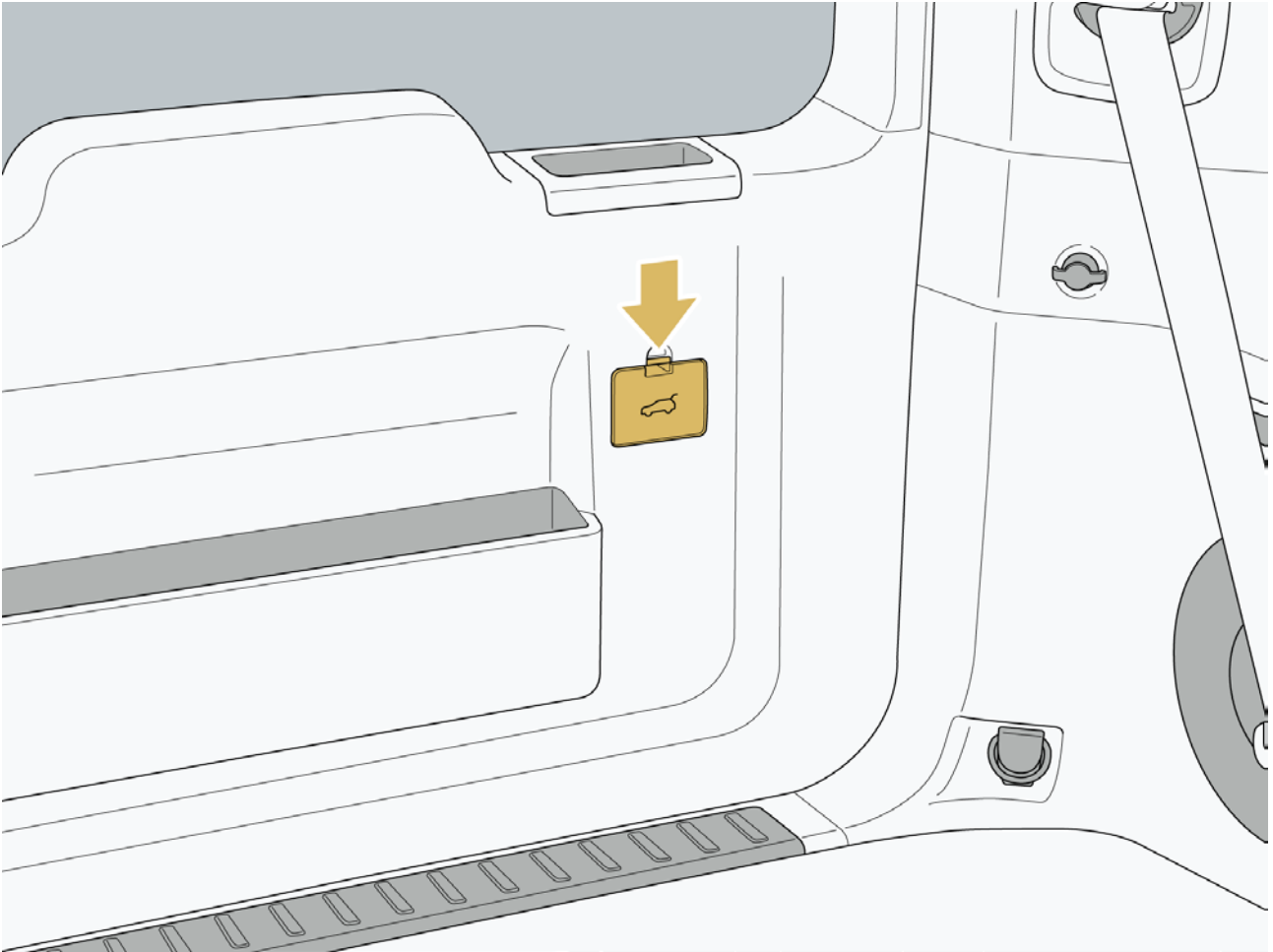

3. Pull the unlocking cable upwards and push the trunk door outward at the same time to unlock and open the trunk door.

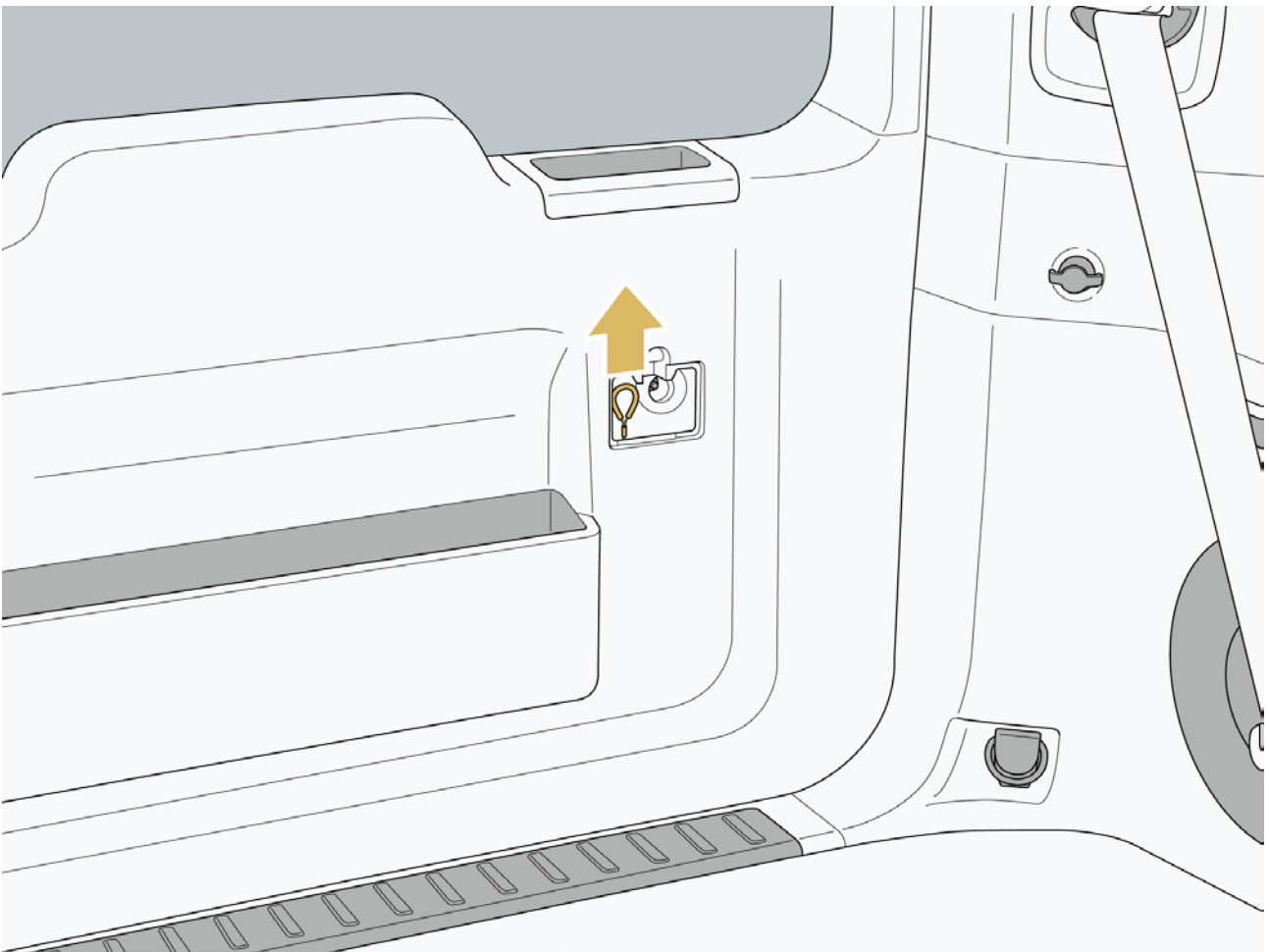

VI. Convenient loading of trunk

When you need to load or unload items in the trunk, you can use the suspension height adjustment button in the trunk to adjust the vehicle body to the appropriate height.

- Convenient loading of trunk

After activating the convenient loading function of the trunk, when the trunk is opened, the air spring automatically lowers to the convenient loading height, making it easy to take out the items in the trunk. To enable or disable the "Automatic Trunk Lowering" function, click "Vehicle Settings → Vehicle → Mode → Convenient Loading of Trunk" on the central control screen.

- Press the button to adjust the height
 1. Press the height adjustment button to increase the height of the vehicle body.
 2. Press the height adjustment button to lower the vehicle's height.

Long press the loading button, and the vehicle height will stop rising and falling with the release of your fingers; Short press the loading button, and the vehicle height will automatically rise and fall to the target height.

6 Operation

Caution

- When adjusting the height, please ensure that there are no obstacles (people or objects) within the vehicle's movement path to prevent injury to personnel or damage to the vehicle.

Hint

- The vehicle height can be restored to the current target height by short pressing the up button, closing the rear tailgate or reaching a speed of 5km/h.
- During the process of lifting and lowering by short pressing the button, short pressing it again can immediately stop the adjustment of the vehicle height.

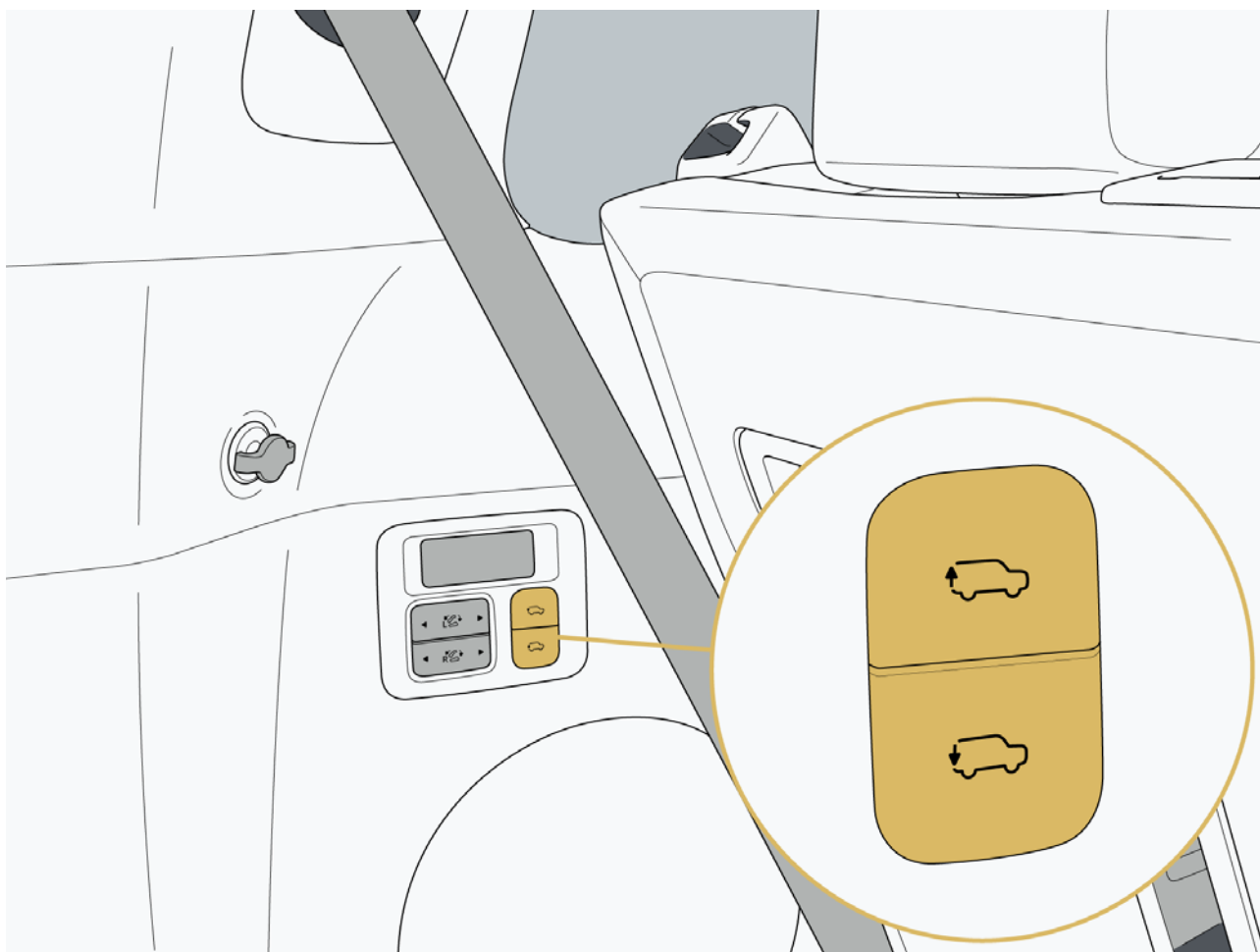

Warning

- The electric suction function does not have an ajar function. Be sure to close the trunk door safely without clipping any objects, including fingers, to avoid pinch injuries or property damage.
- When opening or closing the trunk door, make sure that the surrounding area is safe.
- Do not allow children to operate the trunk door or play near the open trunk door. Unintended closure due to an improperly secured trunk door may result in pinching and injury to their body parts.
- Do not drive the vehicle when the trunk door is not locked normally, to avoid the sudden opening of the trunk door, causing items to fall or accidents. In addition, abnormal locking of the trunk door may cause exhaust gas to enter the car, endangering health and causing death in severe cases.
- Do not sit in the trunk during driving. In the event of emergency braking or a collision, there is a high risk of safety accidents that could lead to injury.
- Be careful when opening the trunk door in strong wind conditions. Under the action of strong wind, the trunk door may be deformed due to too large opening.

Hint

- The vehicle is automatically locked only when the trunk door is in the unlocked state, and the trunk door is still closed after 30 s.

6 Operation

6.3 Seat adjustment

6.3.1 Front seats

I. Adjustment of driver seat

The front seats support electric adjustment. Before driving the vehicle, you can adjust it through the adjustment buttons on the side of the seat.

- Adjust the seat position
 1. Move the front part of the seat adjustment button up/down to adjust the tilt angle of the seat cushion; Move the rear part of the seat adjustment button up/down to adjust the seat height; Push the seat adjustment button forward/backward to adjust the position of the seat.
 2. Move the seat adjustment button forward/backward to adjust the tilt angle of the seat backrest.

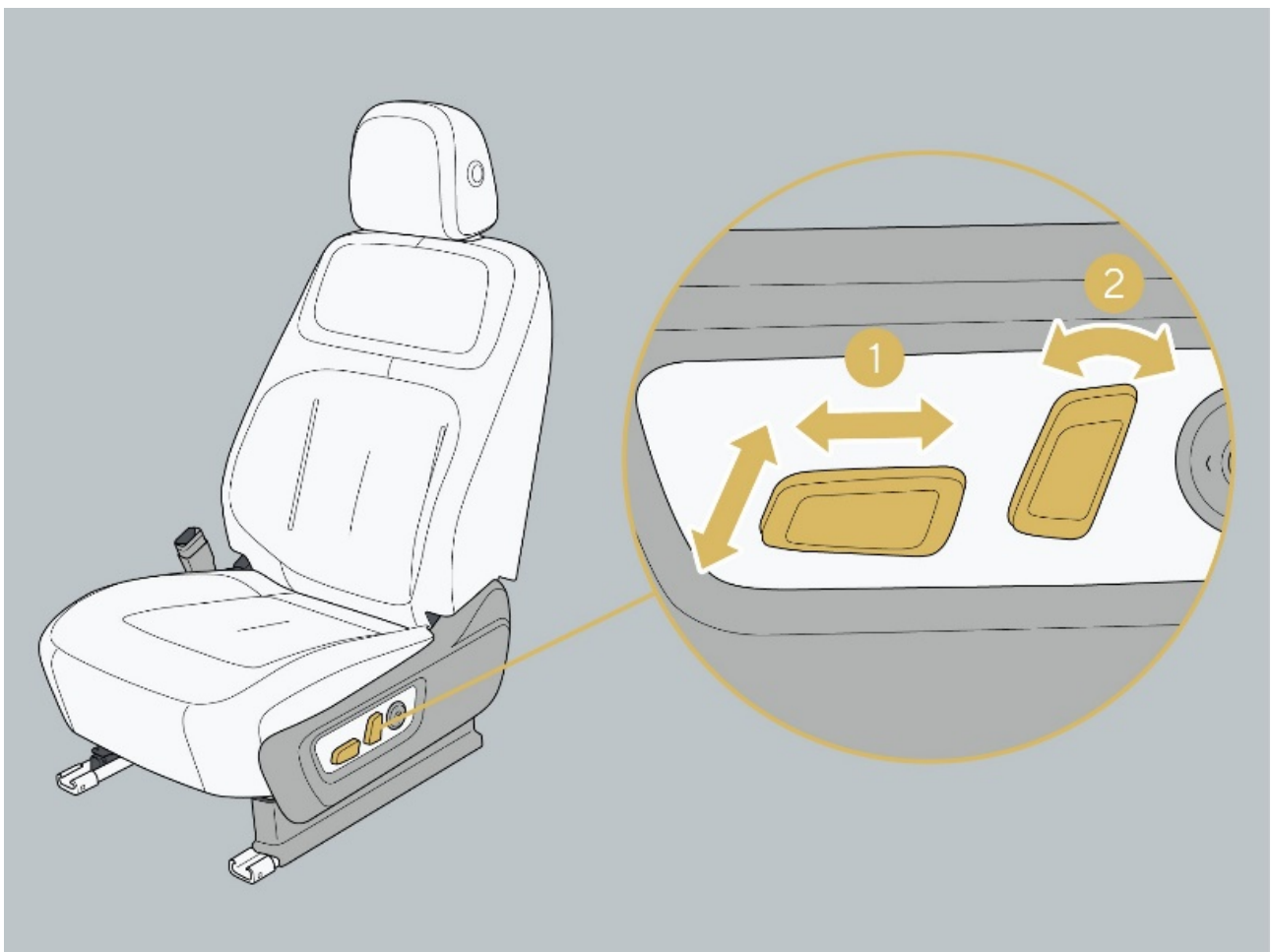

II. Adjustment of front passenger seat

1. Move the rear part of the seat adjustment button up/down to adjust the seat height; Push the seat adjustment button forward/backward to adjust the position of the seat.
2. Move the seat adjustment button forward/backward to adjust the tilt angle of the seat backrest.

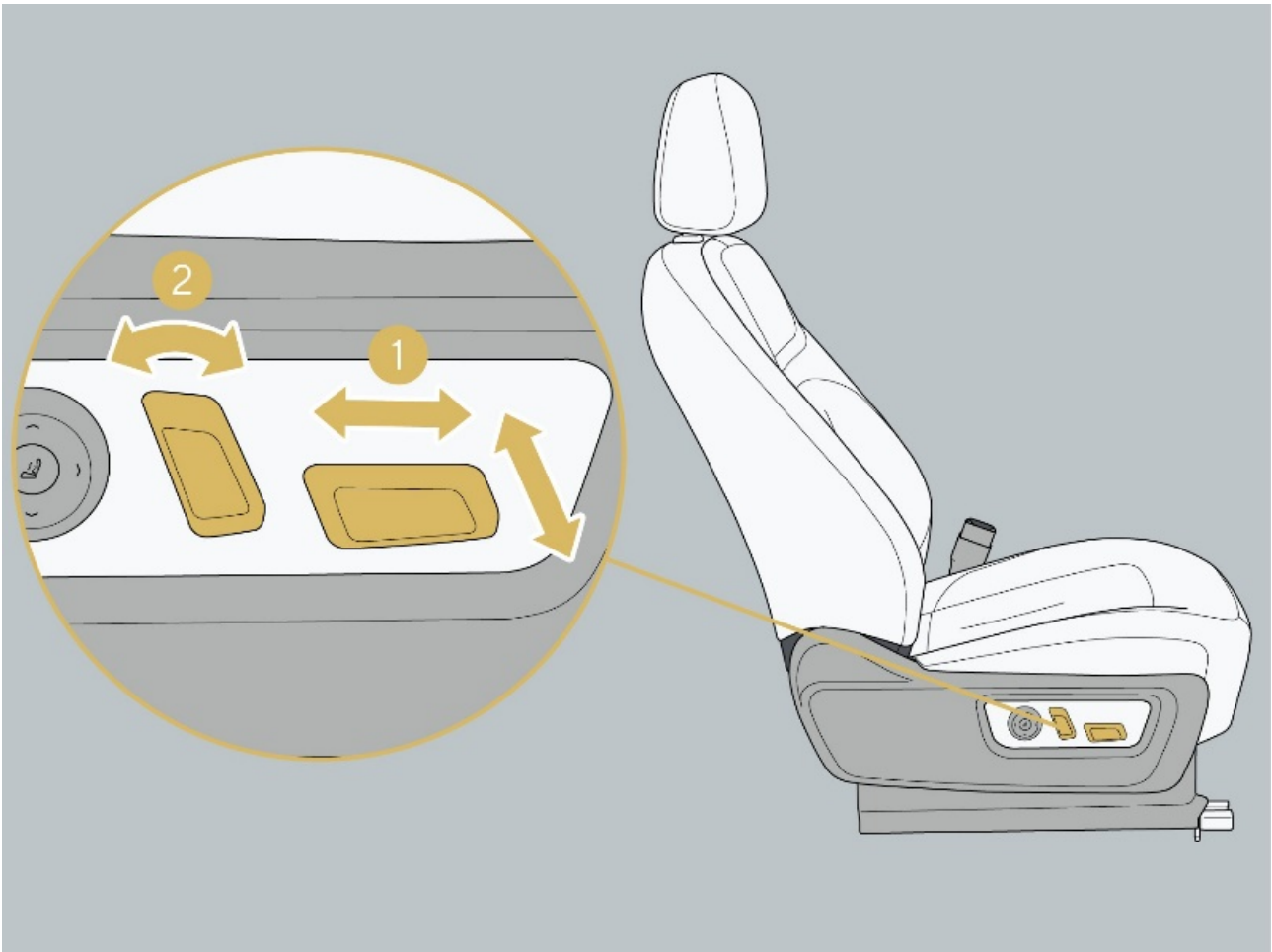

6 Operation

- Front passenger seat boss key
1. Push the seat adjustment button forward/backward to adjust the front or rear position of the seat.
 2. Move the seat adjustment button forward/backward to adjust the tilt angle of the seat backrest.

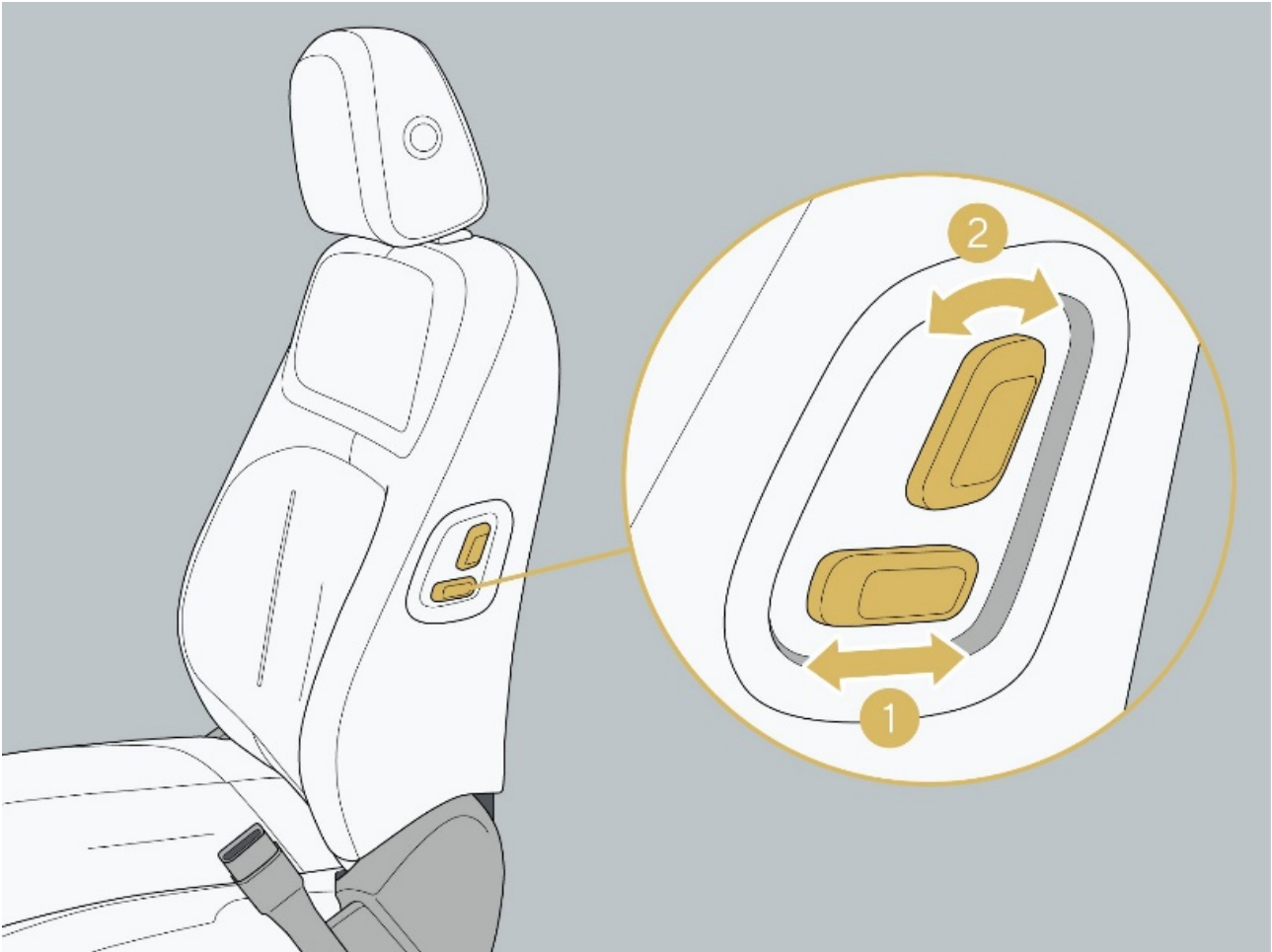

- Adjust the seat waist support
 1. Enhance waist supporting: Press the front part of the waist support button.
 2. Move down: Press the lower part of the waist support button.
 3. Weaken waist supporting: Press the back of the waist support button.
 4. Move up: Press the upper part of the waist support button.

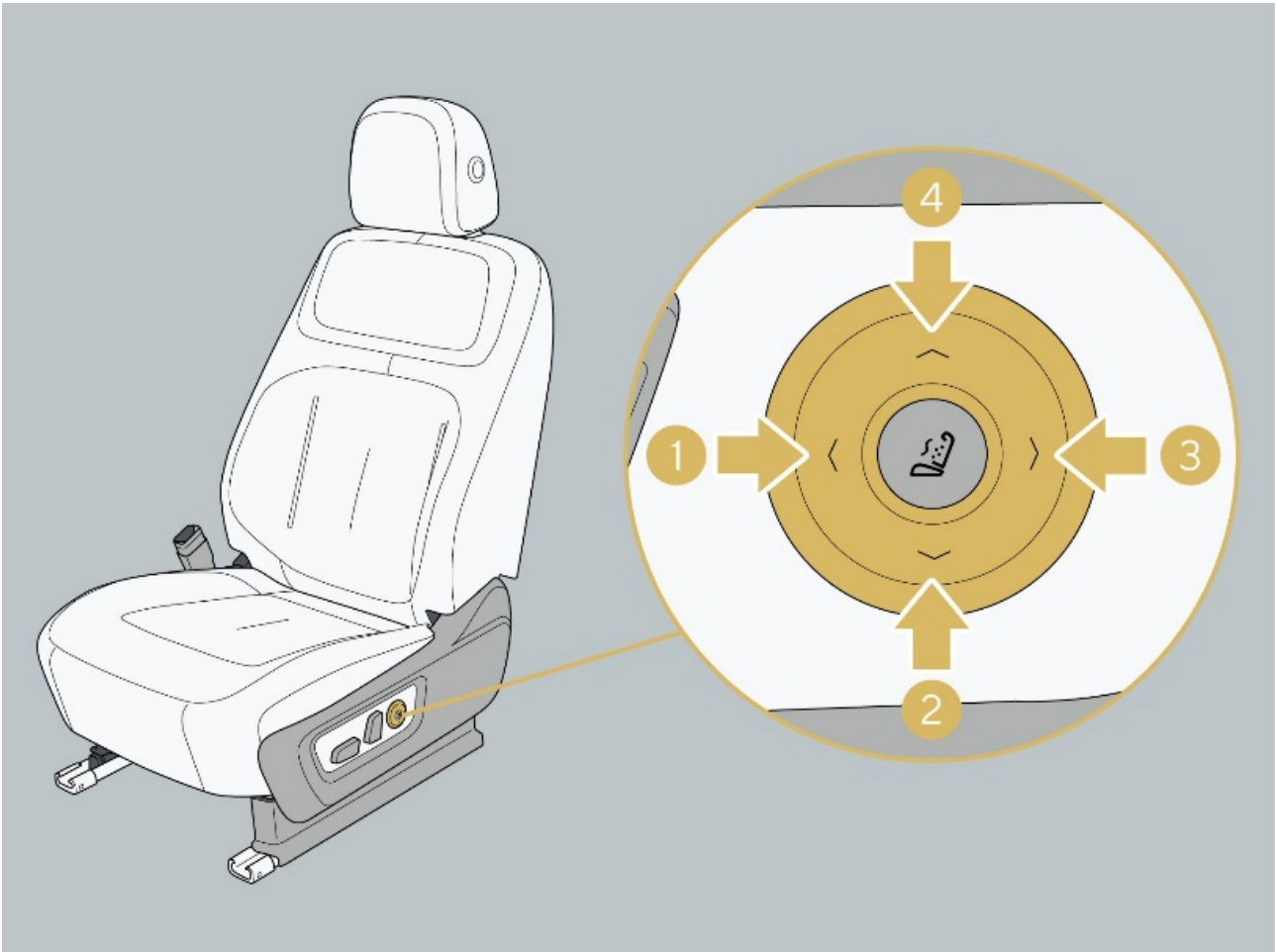

III. Seat massage

1. Activate and deactivate seat massage through the central control screen

Click the "Seat" icon on the A/C system control interface of the central control screen to enter the seat massage control interface.

Activation: Click the "Start Massage" icon to activate the seat massage function.

Deactivation: Click the "Turn off Massage" icon to deactivate the seat massage function.

2. Activate and deactivate seat massage with the button

Activation: When the massage function is off, short press the massage button to activate the massage function.

Deactivation: When the massage function is on, short press the massage button to deactivate the massage function.

6 Operation

After the massage function is activated, short press the seat massage button again to switch the seat massage intensity. The start intensity is strong mode by default, and the switching order is strong, standard, gentle and off.

Hint

- When the massage function is on, operate the waist support adjustment button to deactivate the massage function.
- When the energy-saving mode is enabled, the seat massage function is unavailable.
- The system will automatically turn off the seat massage function when it detects that the seat massage function is on and no one sits on it for 3 minutes.

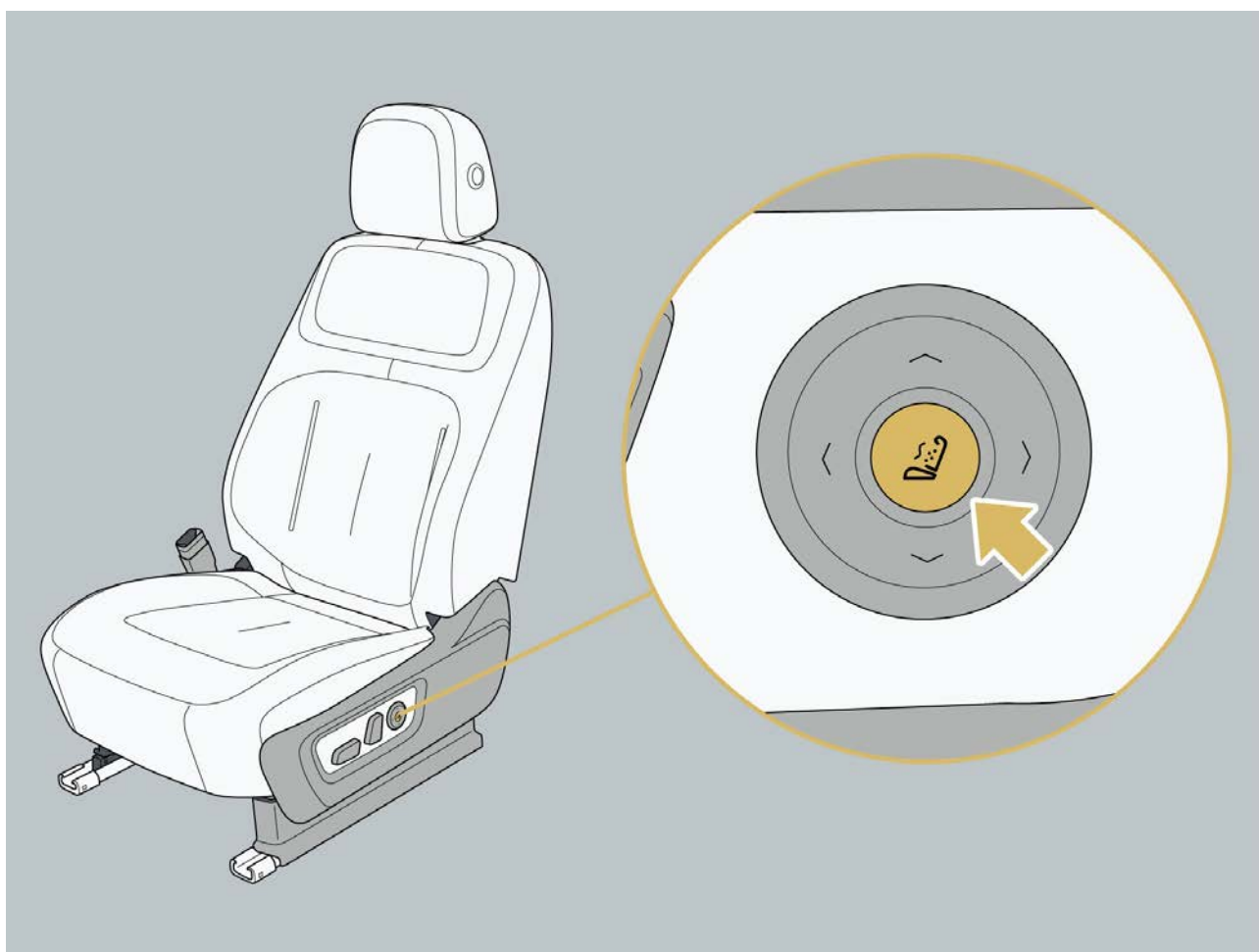

IV. Seat position parameter

Seat travel: 200 mm forward, 60 mm backward.

Up and down travel: 20 mm down, 40 mm up.

Warning

- Do not adjust the driver's seat while driving to avoid losing control of the vehicle due to sudden body tilt.
- Do not tilt the seat backrest too backward. Otherwise it will seriously affect the protection of seat belts and airbags.
- Do not drive the vehicle when the seat and the headrest are not adjusted correctly or the seat belt is not fastened, to prevent it from being unable to provide protection in the event of an accident.
- When adjusting the seat, do not place your hands on the seat movement area to avoid pinching.

6 Operation

6.3.2 Second row seat

I. Seat adjustment (common seat)

- Adjust the seat position (common seat)
 1. Push the seat adjustment button forward/backward to adjust the front or rear position of the seat.
 2. Move the seat adjustment button forward/backward to adjust the tilt angle of the seat backrest.
 3. Adjust the seat armrest: Push the seat armrest up and down. Lift the armrest up to the highest position and then put it down. The armrest can be reset to the lowest position.

Caution

- When seat armrest is lowered, do not place your hands on the armrest movement area to avoid pinching.

Hint

- When the seat backrest is tilted too forward, the seat armrest cannot be locked.



6 Operation

- Adjust the seat waist support (common seat)
 1. Enhance waist supporting: Press the front part of the waist support button.
 2. Move down: Press the lower part of the waist support button.
 3. Weaken waist supporting: Press the back of the waist support button.
 4. Move up: Press the upper part of the waist support button.

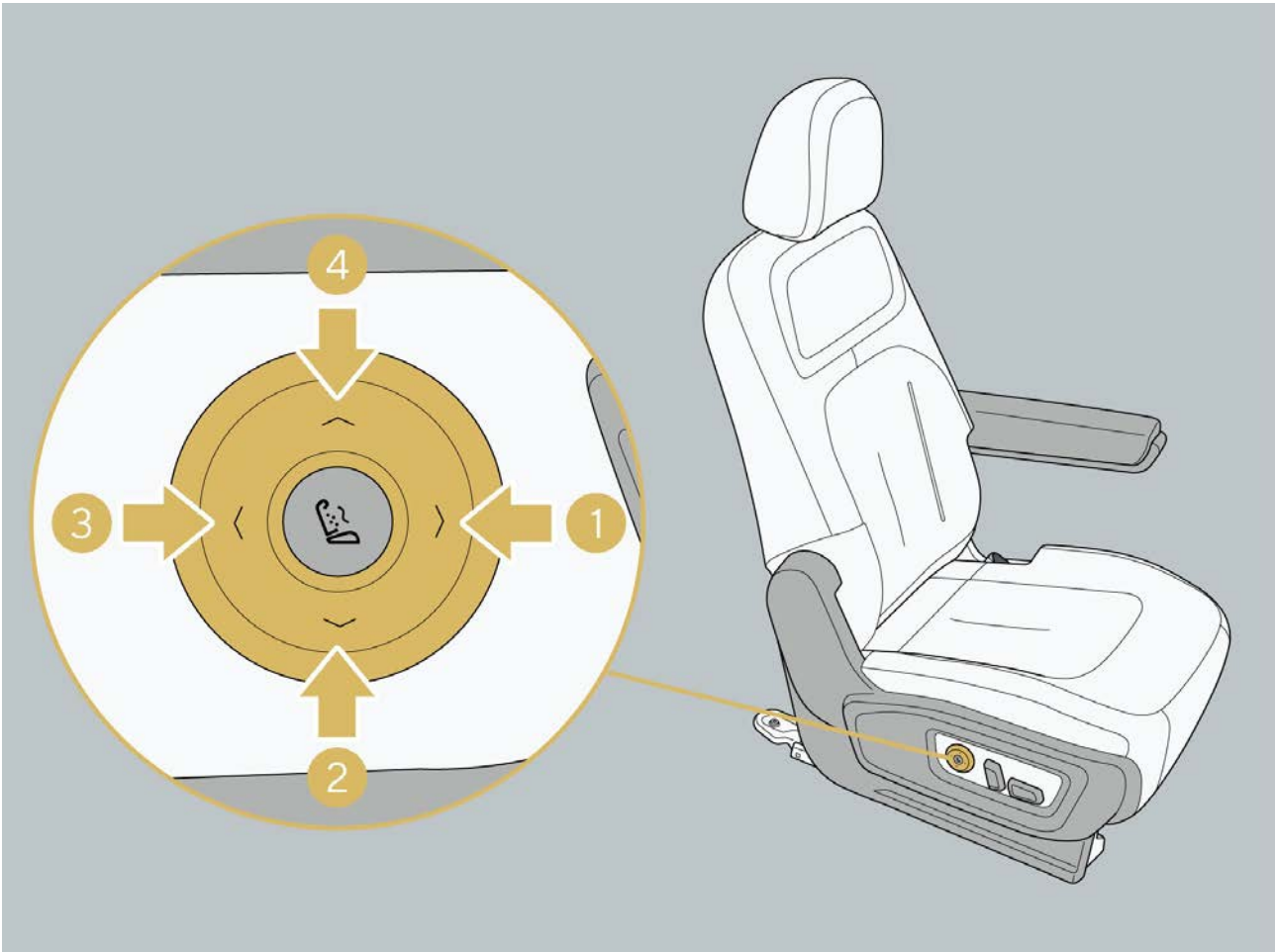

6 Operation

II. Seat massage (common seat)

- Activate and deactivate seat massage with the button (common seat)

Activation: When the massage function is off, short press the massage button to activate the massage function.

Deactivation: When the massage function is on, short press the massage button to deactivate the massage function.

After the massage function is activated, short press the seat massage button again to switch the seat massage intensity. The start intensity is strong mode by default, and the switching order is strong, standard, gentle and off.

When the massage function is on, operate the waist support adjustment button to deactivate the massage function.



- Activate and deactivate seat massage through the central control screen (common seat)

Click "A/C Control Interface → Seat" through the central control screen, and select the second-row left/right seat massage function. Activation: When the massage function is off, click Start massage to activate the massage function.

Deactivation: When the massage function is on, click Close Massage to deactivate the massage function.

Massage intensity: There are three intensity options for seat massage intensity: strong, standard and gentle.

Hint

- When the massage function is on, operate the waist support adjustment button to deactivate the massage function.
- When the energy-saving mode is enabled, the seat massage function is unavailable.
- The system will automatically turn off the seat massage function when it detects that the seat massage function is on and no one sits on it for 3 minutes.

6 Operation

III. Seat adjustment (three- seat version)

- Adjust the seat position
1. Pull the seat adjustment handle upward to adjust the tilt angle of the seat backrest.

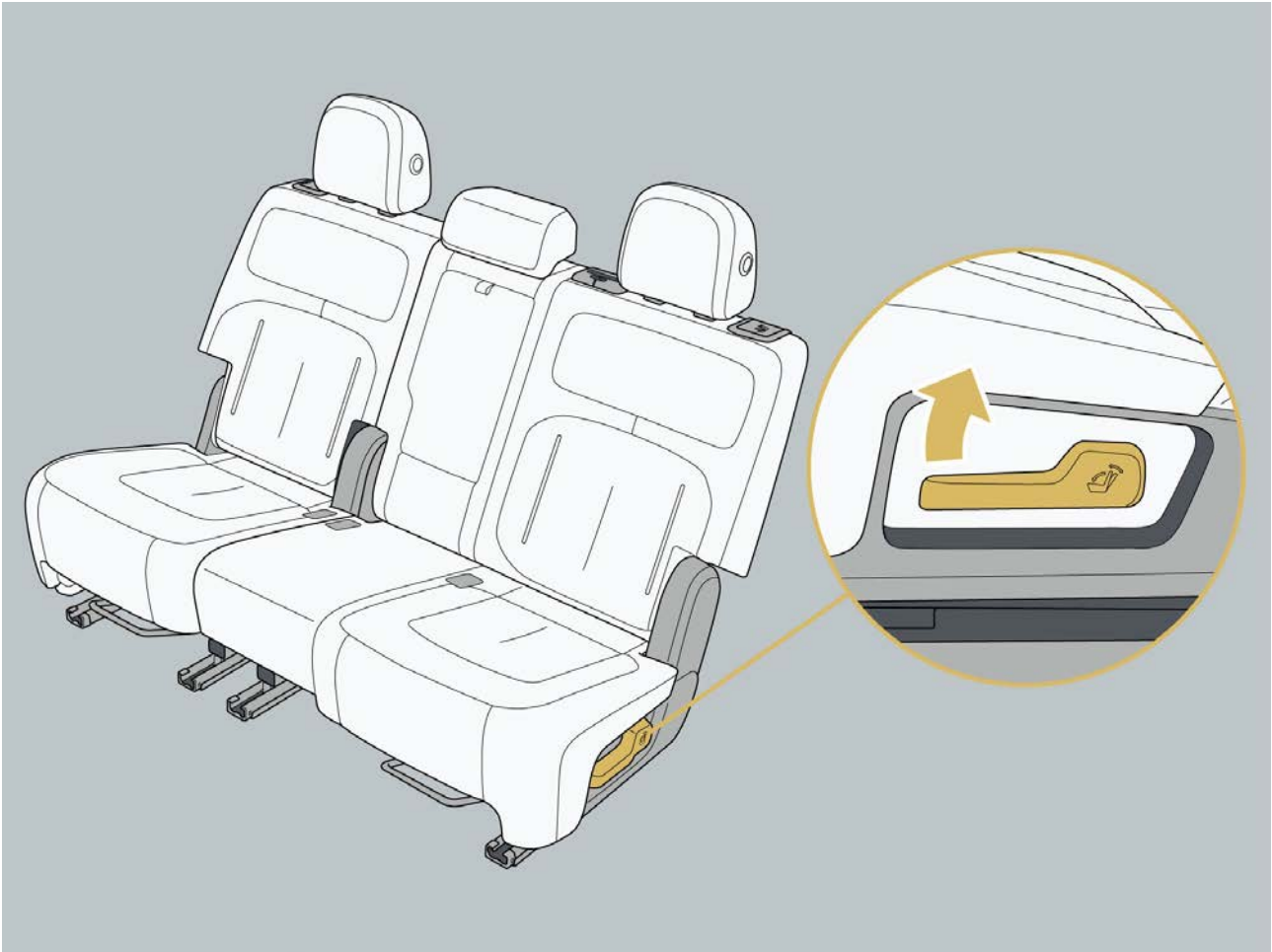

6 Operation

2. Pull the unlock handle upward to move the seat forward and backward to the appropriate position.

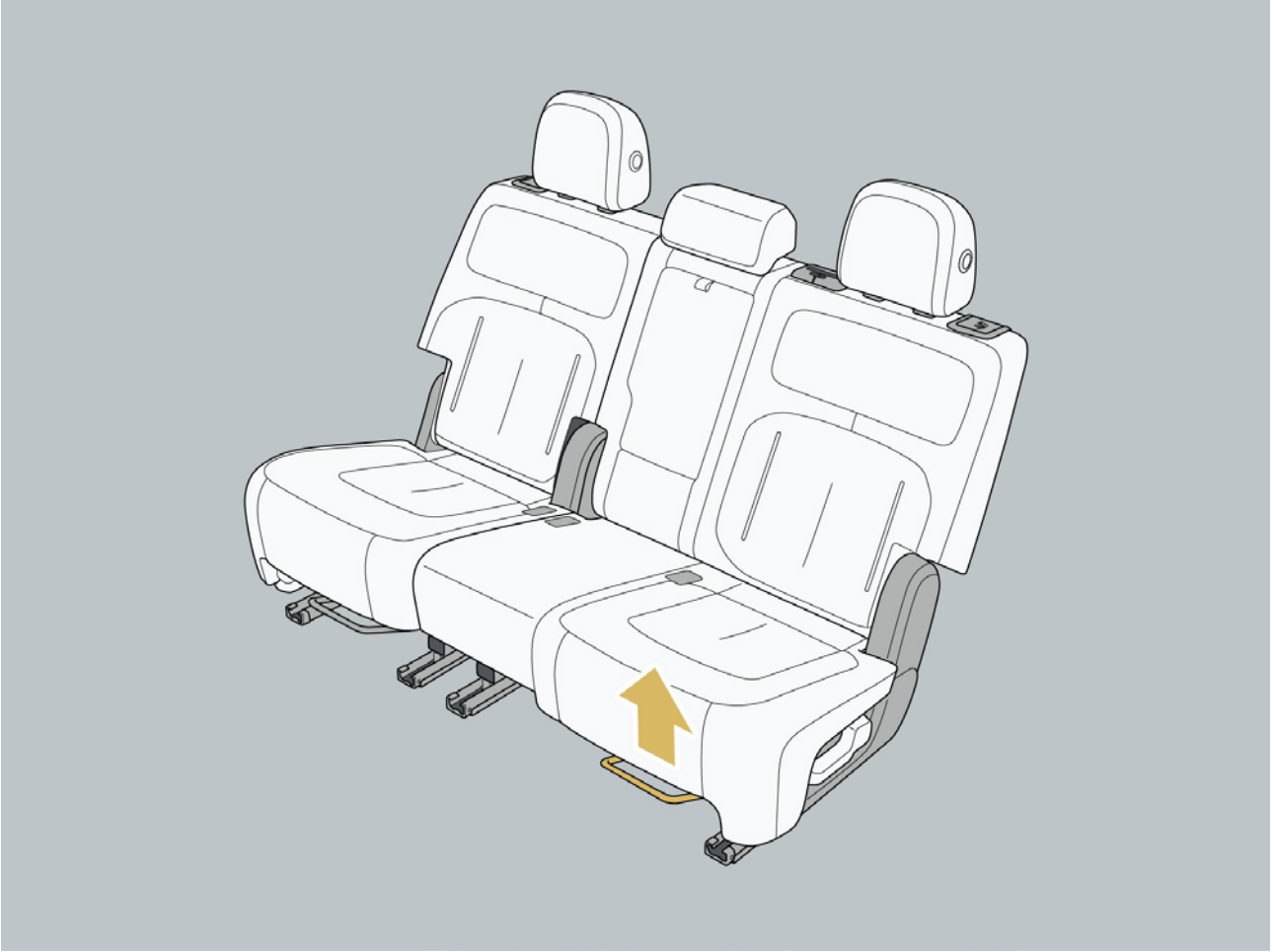

6 Operation

3. Seat folding and restoration

- Folding: Push the shoulder unlock handle upwards, and the seat backrest folds forward after unlocked.
- Recovery: Lift the seat up to the seat locked position until you hear a “click” sound.

Hint

- When folding the seat, please adjust the headrest to the lowest position first.

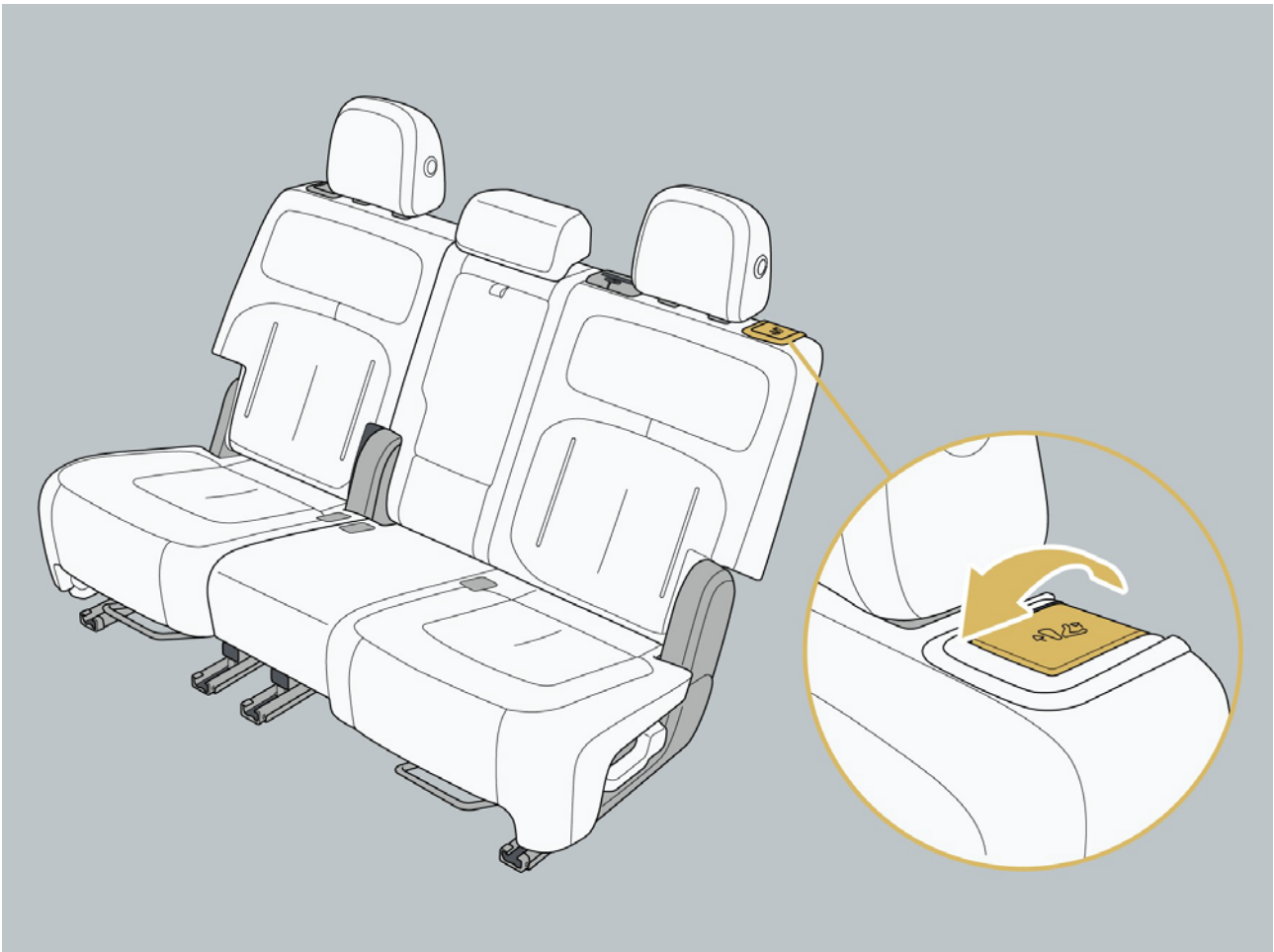

IV. Seat adjustment (aviation seat)

- Adjust the seat position (aviation seat)
 1. Move the seat adjustment button forward/backward to adjust the unfolding angle of the legrest.
 2. Pull the seat buttons back and forth to adjust the front or rear position of the seat; Pull the rear of the adjustment button up and down to adjust the tilt angle of the seat cushion.
 3. Move the seat adjustment button forward/backward to adjust the tilt angle of the seat backrest.

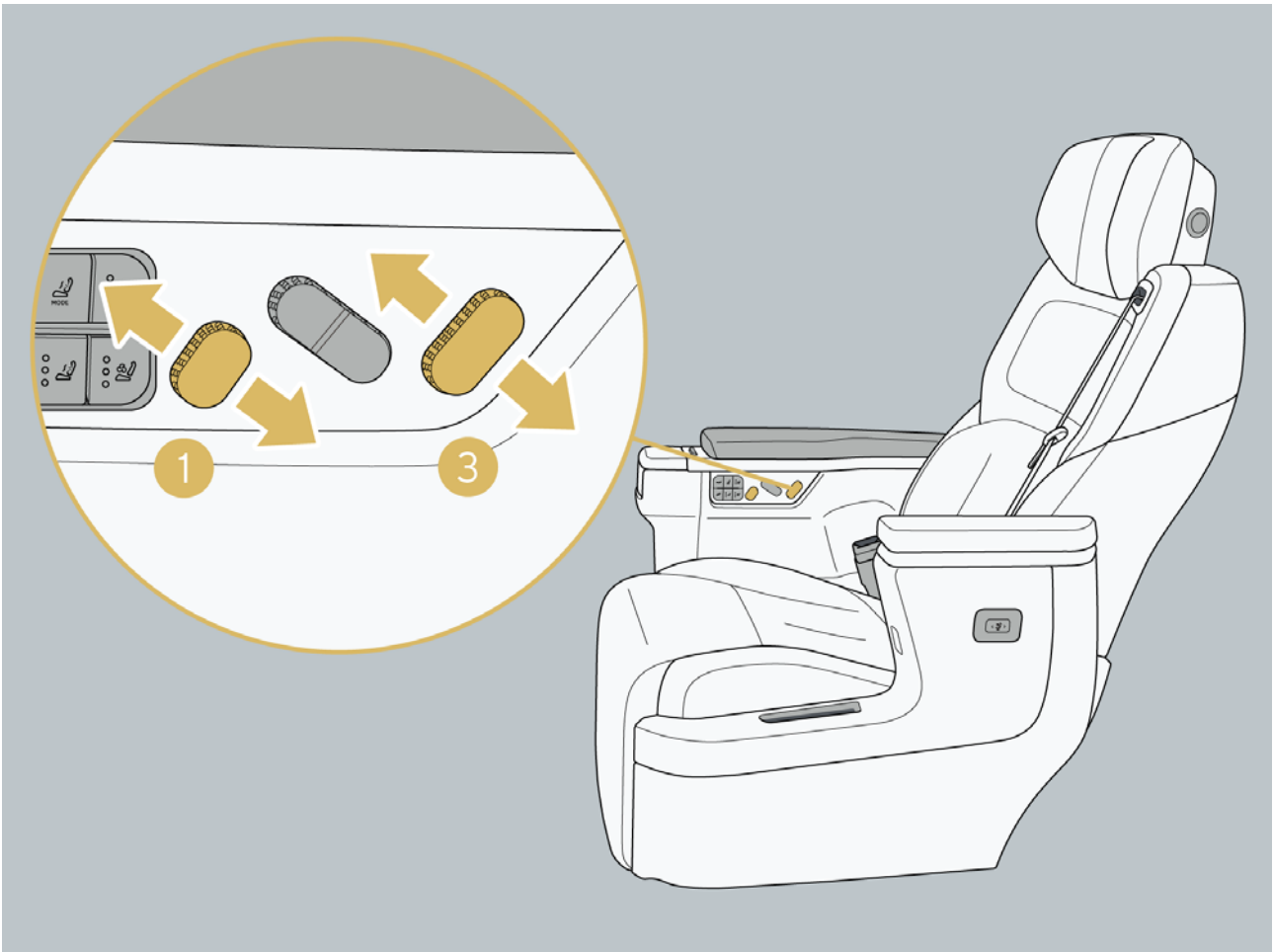

6 Operation

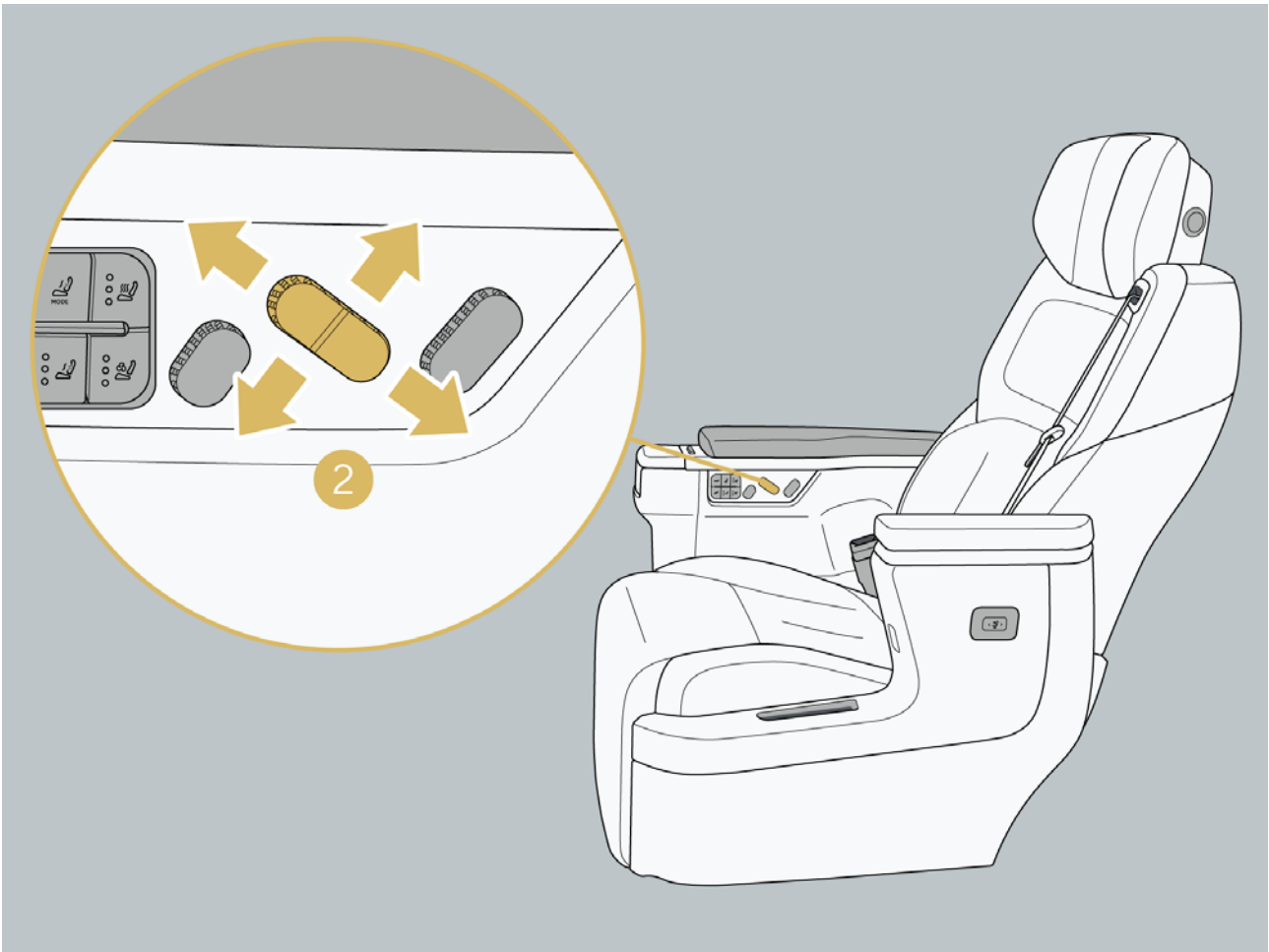

V. Seat massage (aviation seat)

1. Activate and deactivate seat massage through the central control screen (aviation seat)

Click "A/C Control Interface → Seat" through the central control screen, and select the second-row left/right seat massage function.

Activation: When the massage function is off, click Start massage to activate the massage function.

Deactivation: When the massage function is on, click Close Massage to deactivate the massage function.

Massage intensity: There are three intensity options for seat massage intensity: strong, standard and gentle.

Massage mode: There are 9 seat massage modes for option, including: full circulation, back activation, back relaxation, back relief, spinal stretch, waist activation, waist stretch, full back relief and shoulder relaxation. You can choose the seat massage mode according to your preference.

2. Activate and deactivate seat massage with a button (aviation seat)

Activation: When the massage function is off, short press the massage button to activate the massage function.

Deactivation: When the massage function is on, short press the massage button to deactivate the massage function.

When the massage function is on, operate the waist support adjustment button to deactivate the massage function.

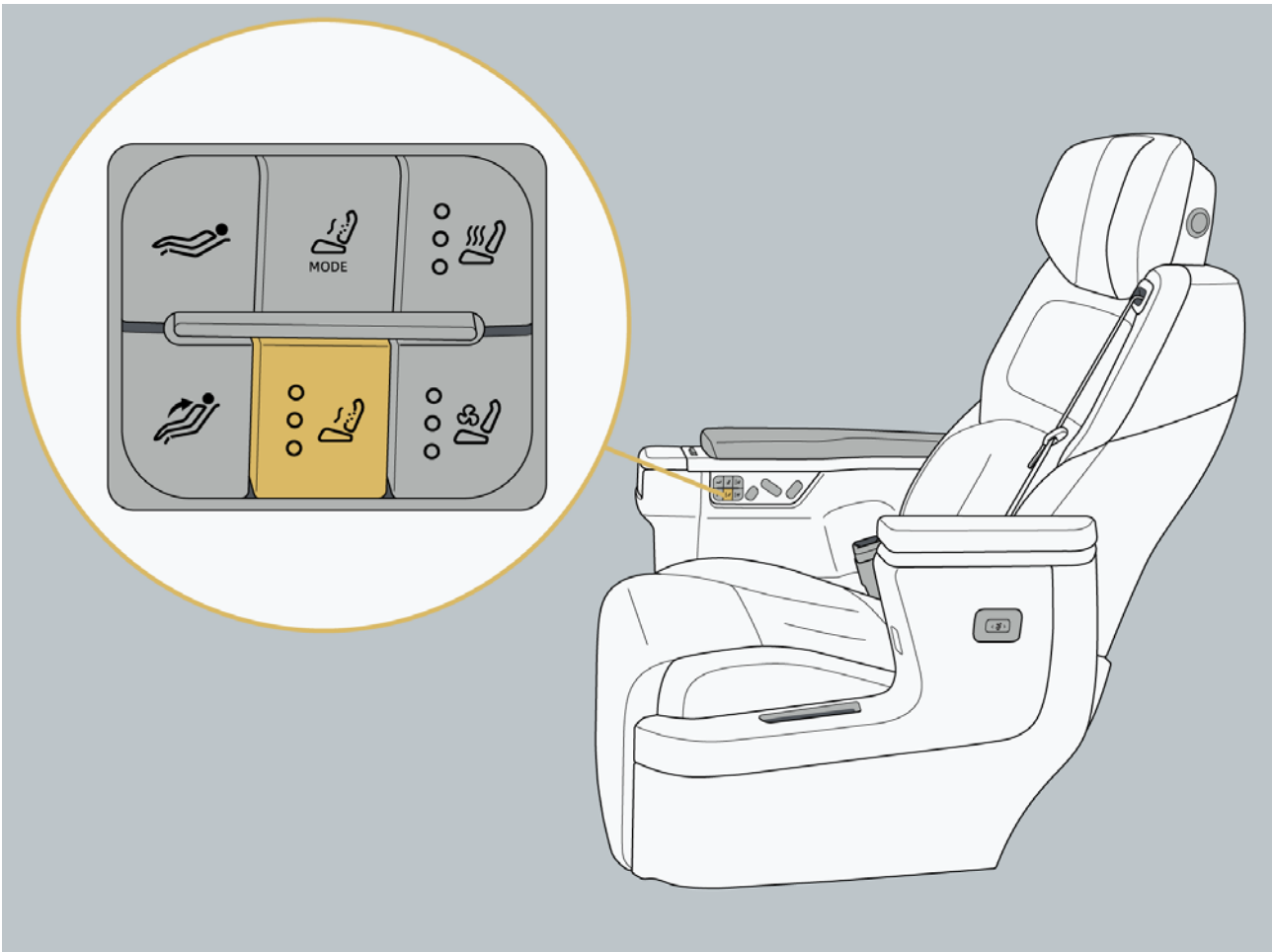

- Adjust the seat position through the central control screen (aviation seat)

Click "Vehicle Settings → Vehicle → Seat" through the central control screen. Select the second-row left/right seat to adjust the front/rear movement of the seat, the angle of the backrest and the leg support.

- Second-row seat comfort mode (aviation seat)

The comfort mode of the second-row seats can be turned on or off through "Vehicle Settings → Vehicle → Seat → Comfort Mode" on the central control screen.

Or press the "Comfort Mode" button of the second-row seat, and the seats will automatically adjust the front and rear directions, seat angles, and leg rest positions, so that they can move to the preset position of lying flat for rest.

6 Operation

When using the "Comfort Mode" function, ensure that there are no occupants in the first and third-rows.

Warning

- Do not tilt the seat too much during driving, to avoid the waist seat belt may slip over the hip in an accident and directly cause the abdomen to be strangled, or the shoulder seat belt may contact with the neck, resulting in serious injury or death to the occupant.

Hint

- During the Comfort Mode adjustment or in the comfort mode, adjust any position of the seat to stop adjusting the comfort mode and maintain the current position. Press the Comfort Mode button again to exit the Comfort Mode.

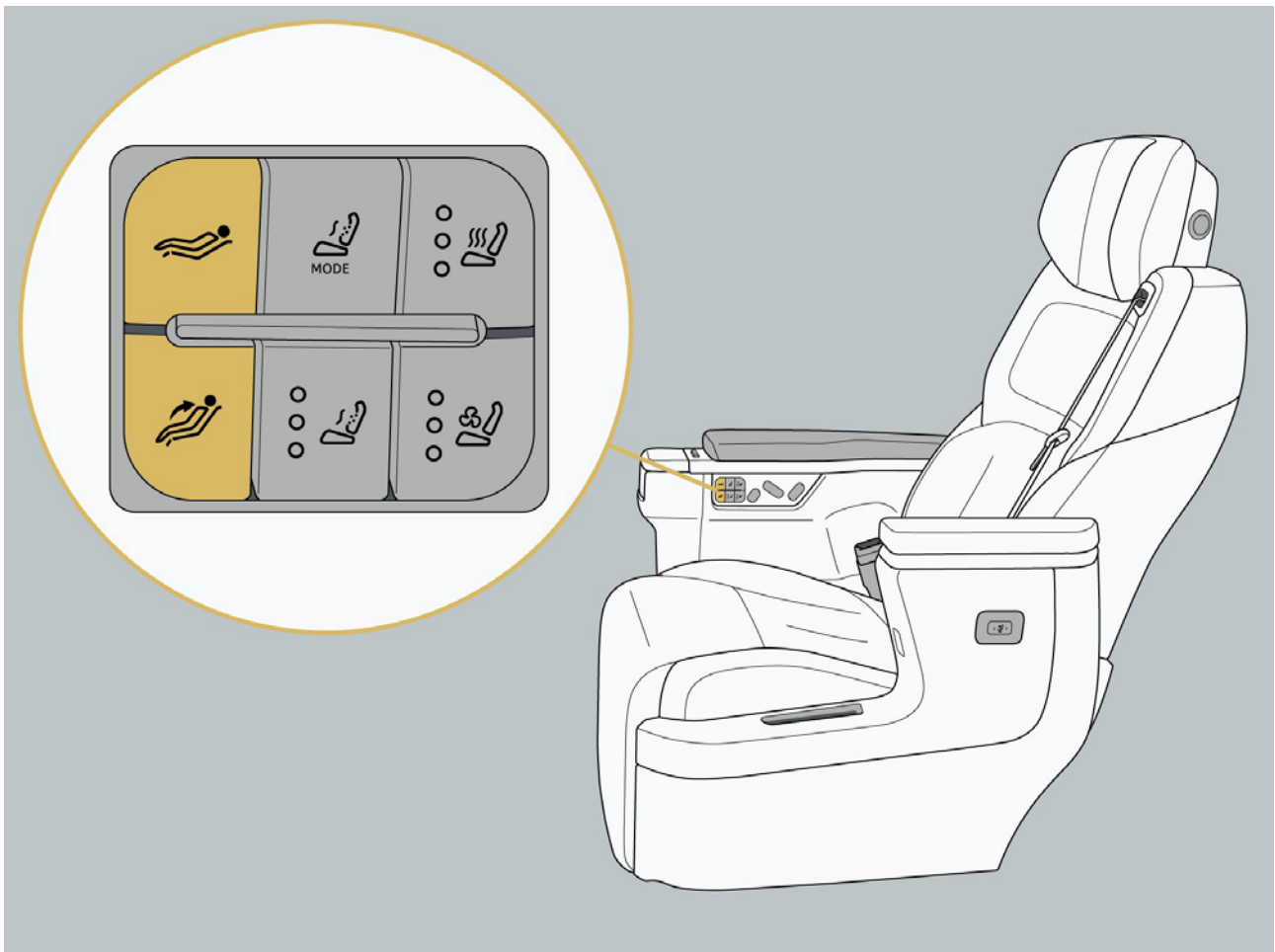

- Second-row easy entry (aviation seat)

When the gear is in P position and there are no occupants in the second-row seat, press the front end of the "One-click Entry" button, and the second-row seat will automatically adjust the backrest angle,

6 Operation

leg rest angle, and seat angle while the seat moves forward to the set position, facilitating people to enter and exit. Press the rear end of the "One-click Entry" button to restore the seat to the set position.

Caution

- When using the easy access function, do not place items on the seat to avoid damaging the seat.
- When using the easy entry function, do not allow people to sit on the seat to avoid pinching.

Hint

- In the process of easy entry adjustment, operate any switch of the second-row seat to facilitate the exit of the easy entry function.
- In the process of easy entry adjustment, when it is detected that there are occupants in the second-row seat, the easy entry function stops, and the seat stops moving.
- In the process of easy entry adjustment, press the easy entry button to pause the easy entry function. Repress the easy entry button within 30 s to continue to execute the easy entry function. The function exits after over 30 s.

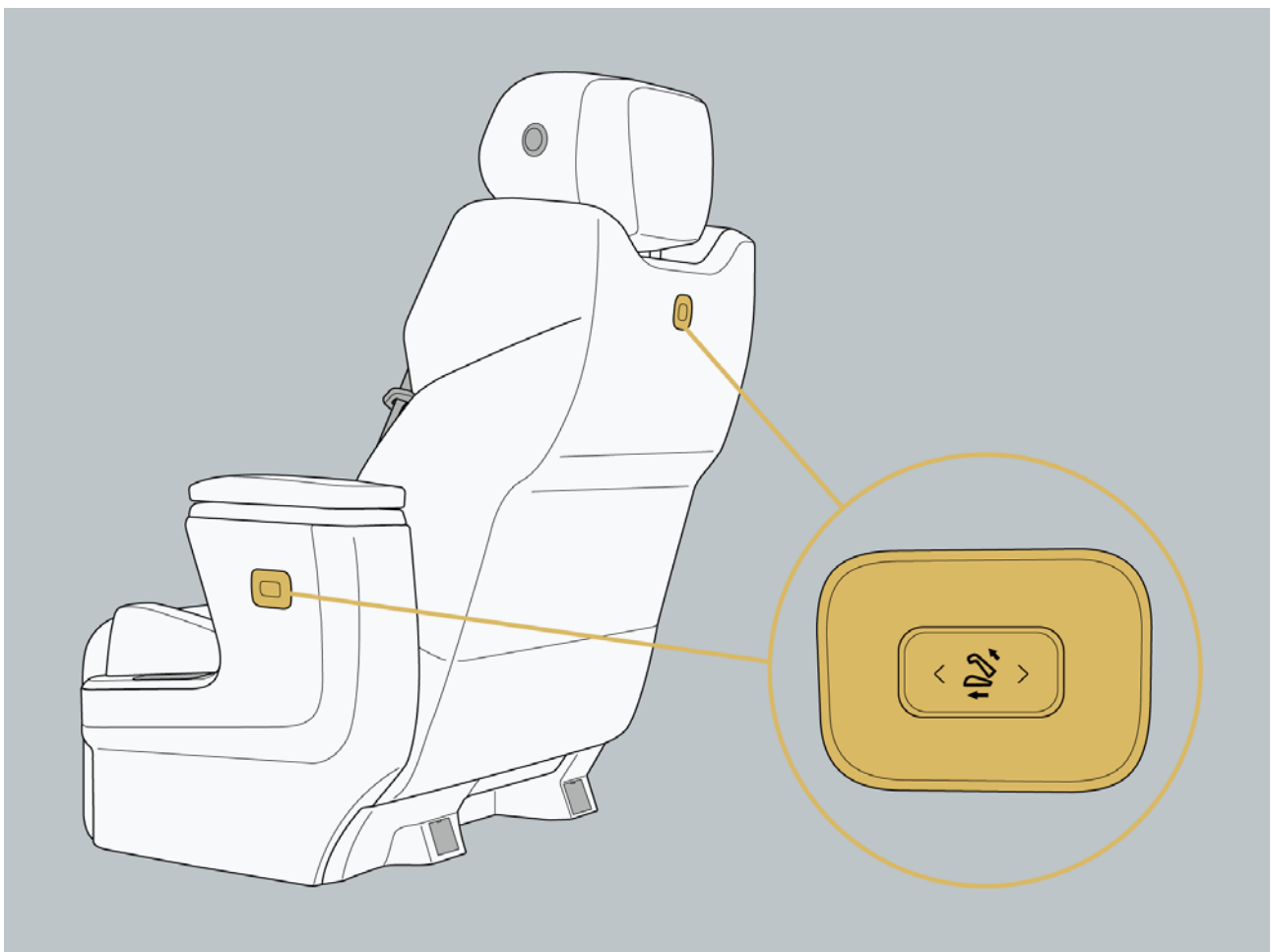

6 Operation

VI. Seat position parameter

Seat backrest angle: 25°

Common seat travel: 110 mm forward, 110 mm backward.

Aviation seat travel: 195 mm forward, 110 mm backward.

6.3.3 Third row seat

I. Adjust the seat backrest tilt angle

- Move the seat adjustment button forward/backward to adjust tilt angle of the seat backrest.

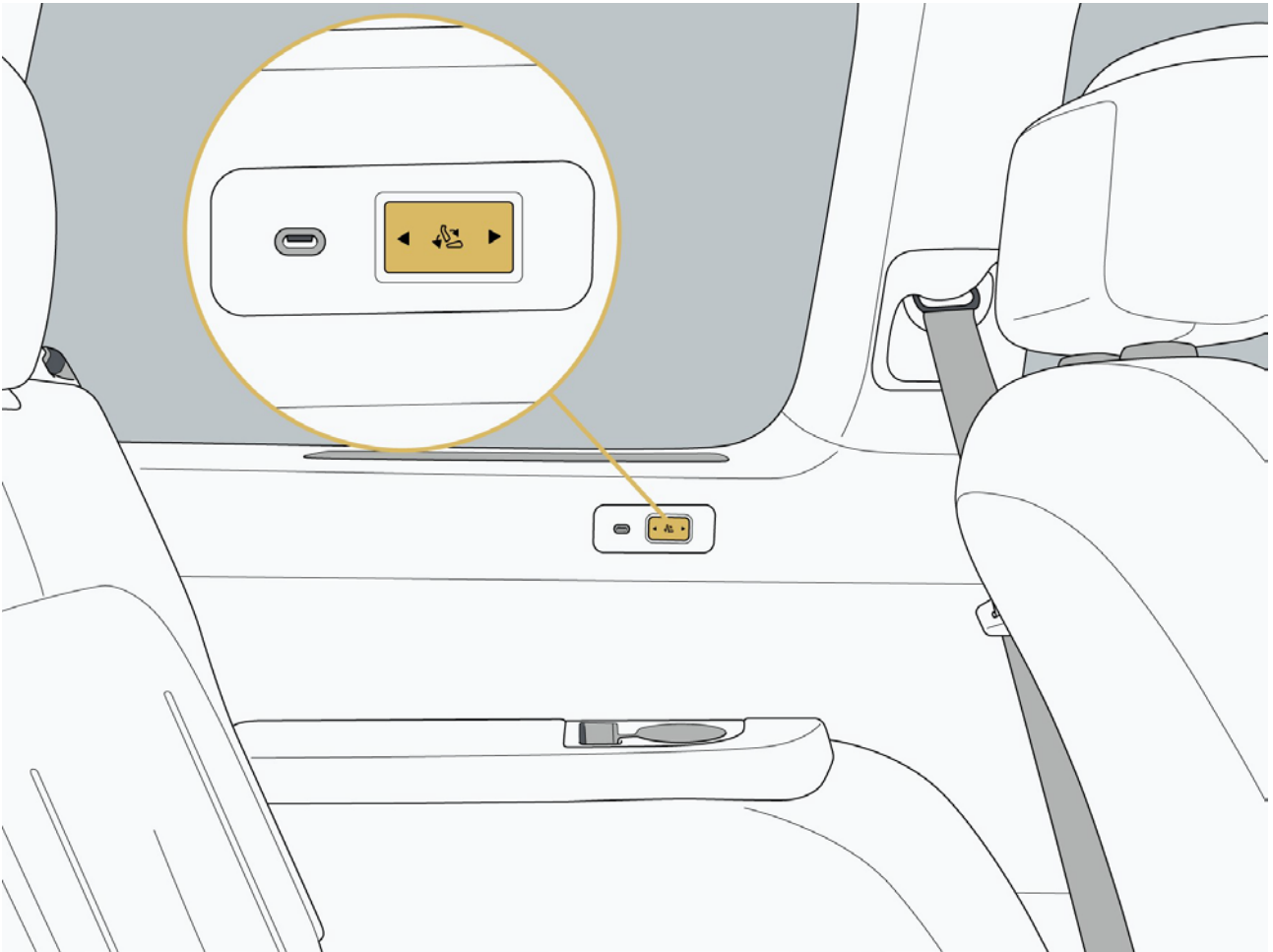

6 Operation

- Long press the front part of the seat folding switch to adjust the seat backrest forward. Long press the rear part of the seat folding switch to adjust the seat backrest backward.

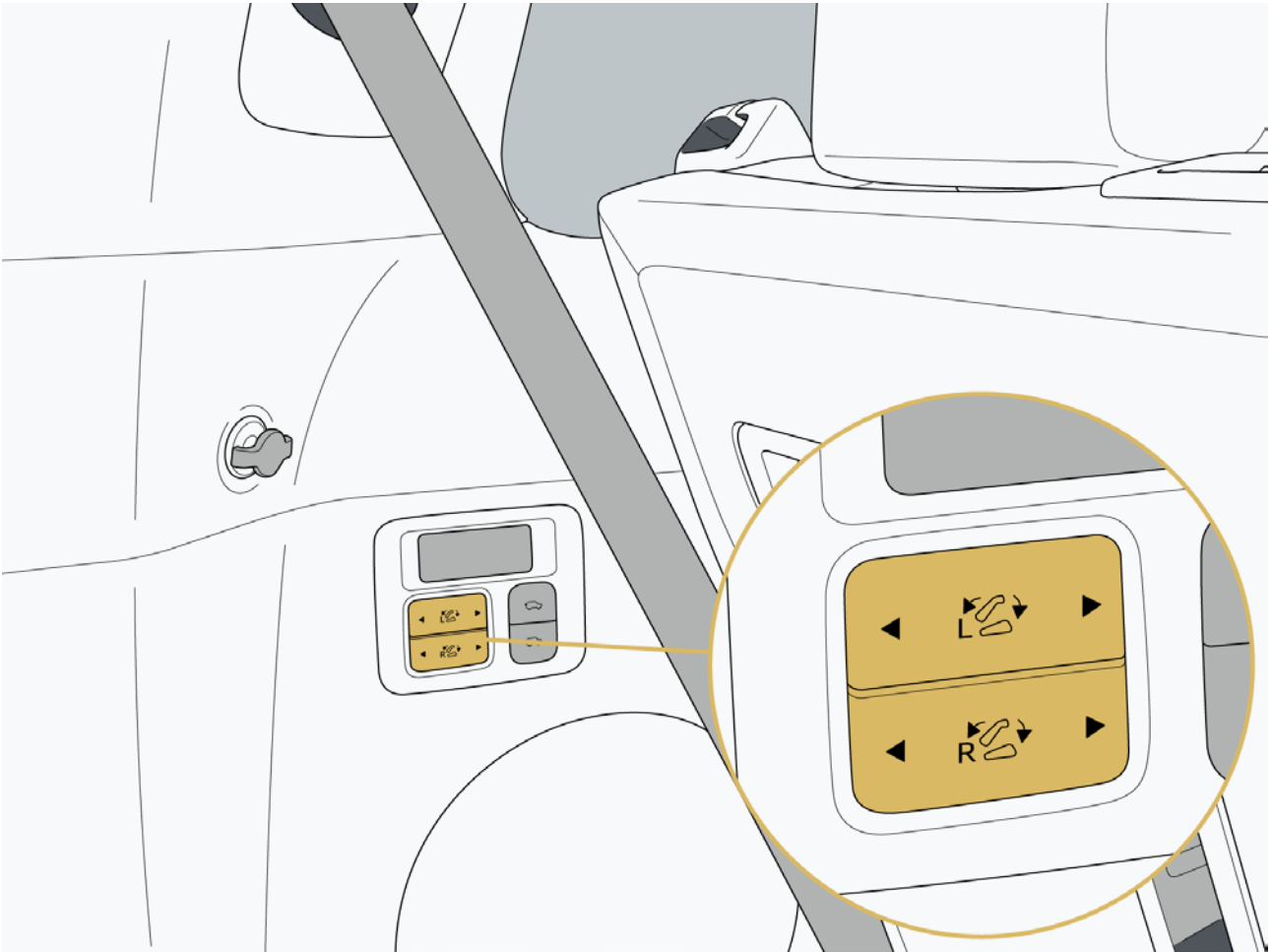

II. Fold down the seat backrest

1. Adjust the third-row seat headrests to the lowest position.
2. Push the shoulder unlock handle upwards, and the seat backrest folds forward.

Hint

- When folding down the third-row seats, if the second-low seat interferes with the folding down/lifting of the third-row seat backrest, first move the second-row seat forward to a position that does not interfere, and then carry out the folding down/lifting action.
- The seat backrest can be adjusted appropriately by shoulder unlock handle.

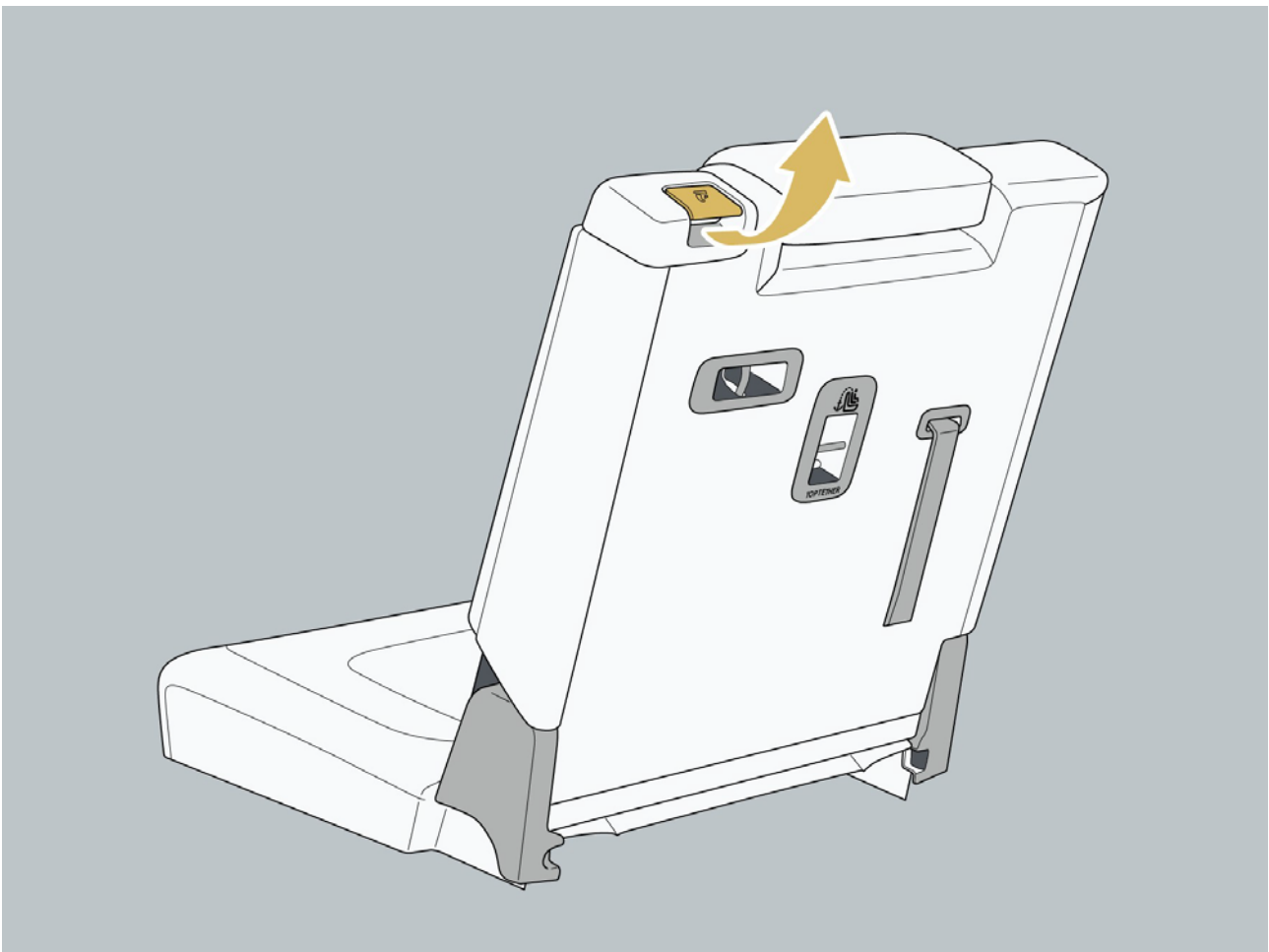

6 Operation

III. One click folding and restoration of seat

Short press the front part of the folding switch, and the seat backrest will fold forward. Short press the rear part of the folding switch to restore the seat back.

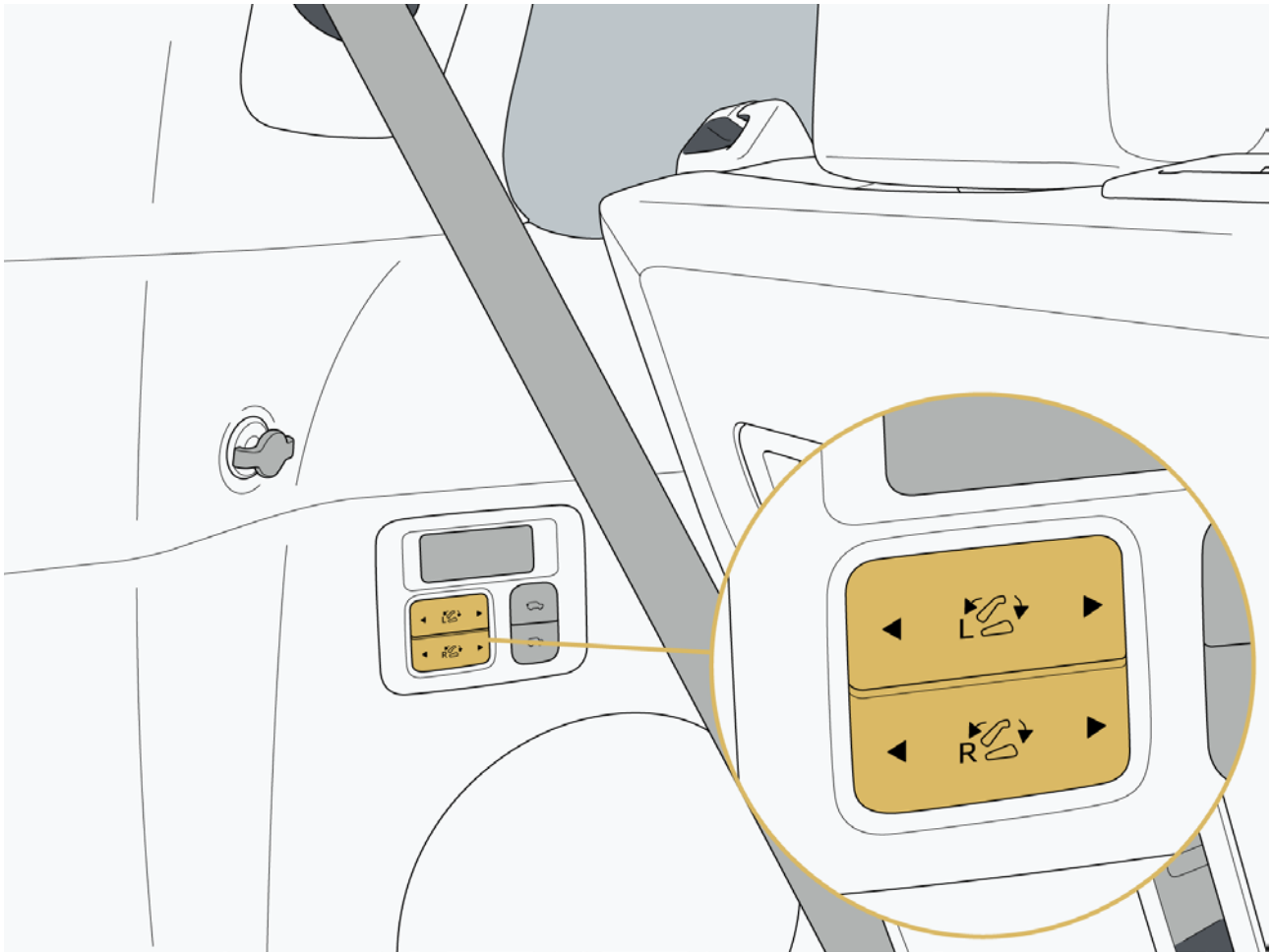

IV. Lift the seat backrest

Lift the seat up to the seat locked position until you hear a “click” sound. After the seat is lifted, gently shake the seat back and forth to ensure that the seat is locked.

Caution

- Before folding the seat backrest, make sure that the seat belt is in an unfastened state to avoid damaging the seat or seat belt.
- Before folding the seat backrest, make sure that there are no items in the third-row foot area and the seat to avoid damaging the seat or other items.

6.3.4 Headrest

The headrest is an important part of protecting the driver and passengers. Correctly adjusting the seat headrest can effectively reduce the injury to the neck in case of a collision.

I. Headrest height

Adjust the seat headrest according the height to make the ears flush with the center of the headrest, ensuring that the entire head is well supported.

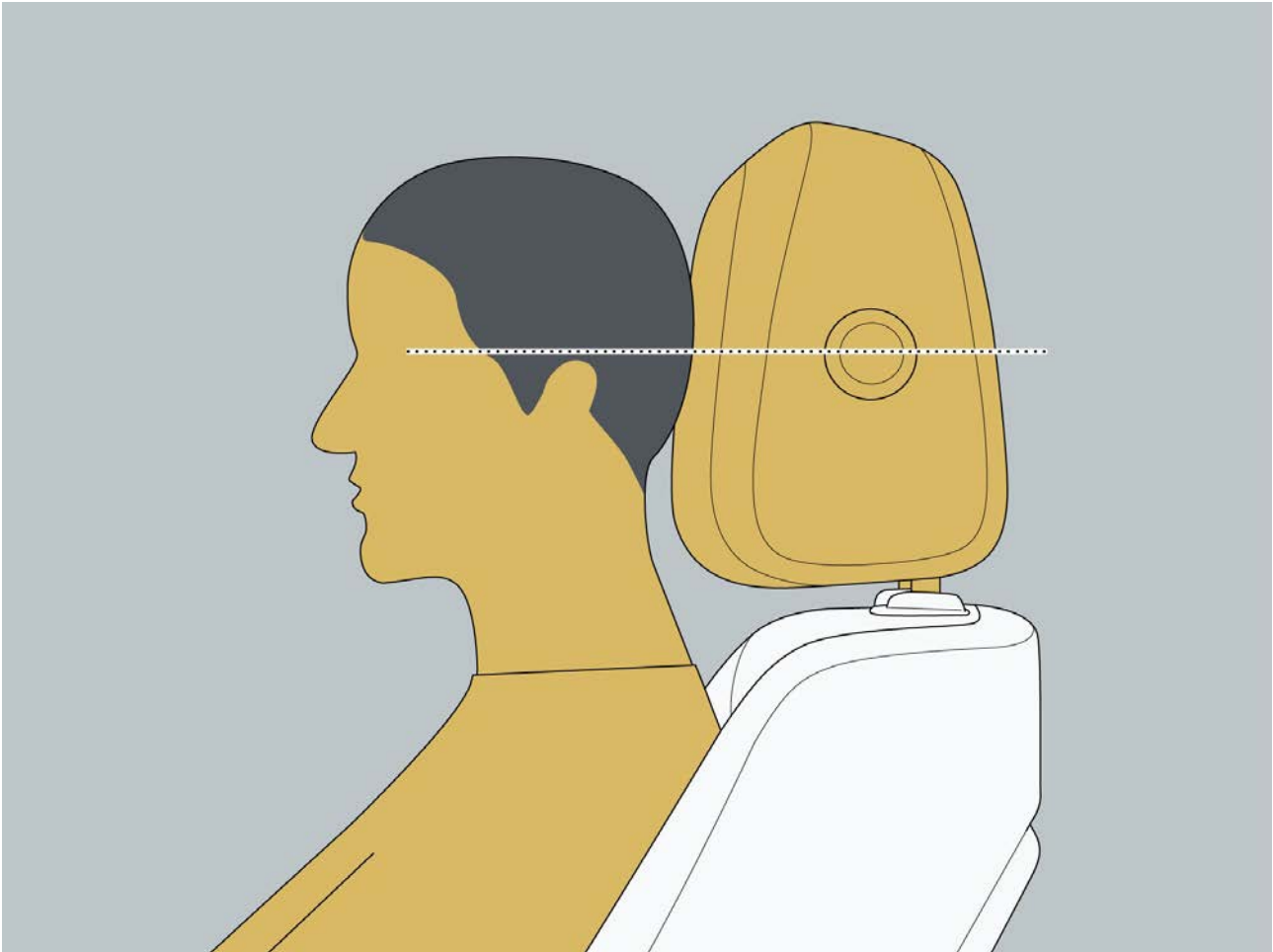

6 Operation

II. Front row headrest height adjustment (common seat)

Upward adjustment: Pull up the headrest to the desired position, and the adjustment is completed. After adjusting to the desired position, press the headrest again to ensure that the headrest is locked.

Downward adjustment: Press the headrest side unlocking button, press the headrest down to the desired position, and then release the unlocking button to complete the adjustment. Press the headrest again after adjusting it to the desired position. Make sure that the headrest is locked.

Hint

- The adjustment method of the second-row common seat headrests is the same as that of the front-row headrest.

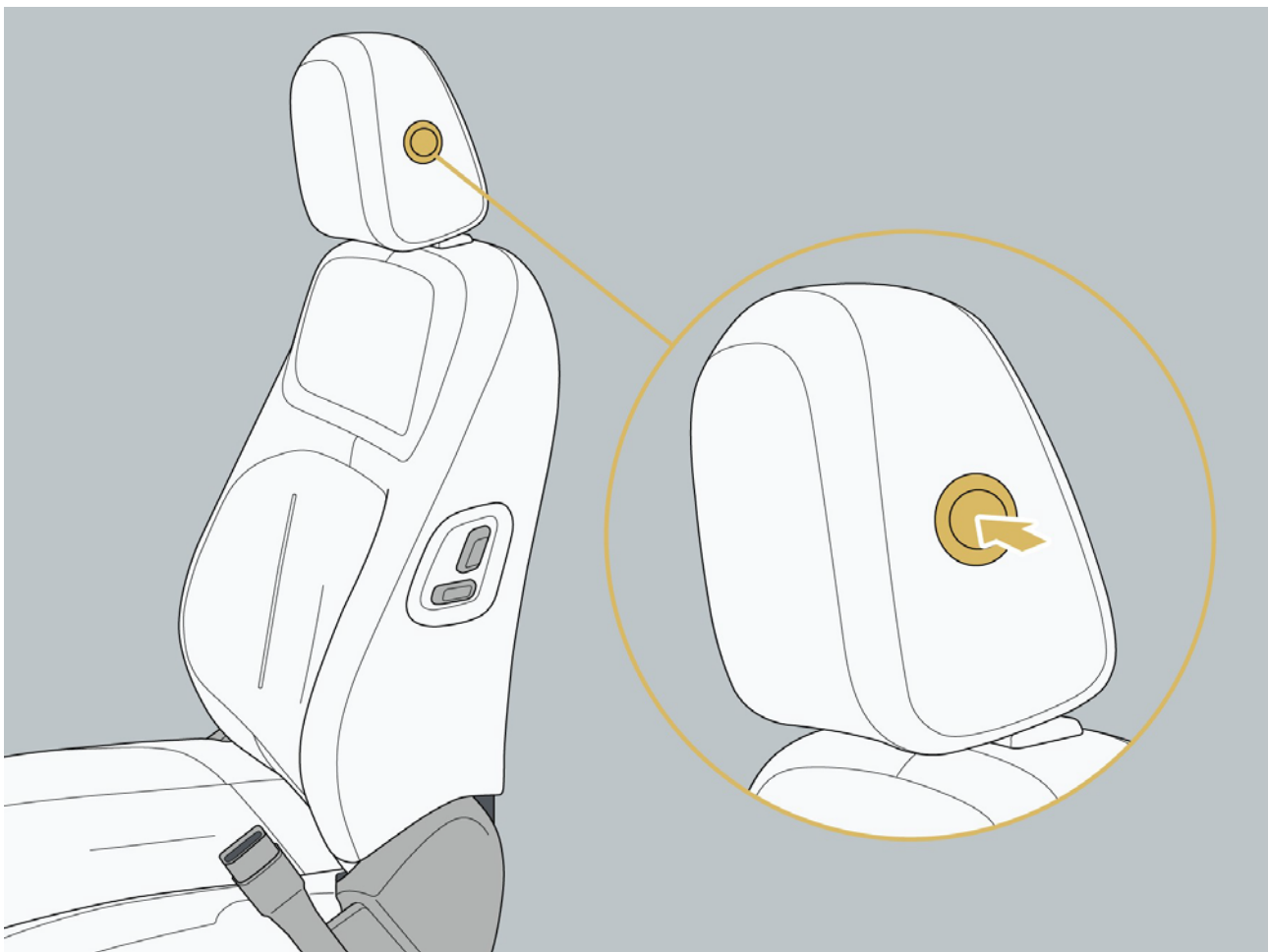

III. Second-row headrest adjustment (aviation seat)

Upward adjustment: Pull up the headrest to the desired position, and the adjustment is completed. After adjusting to the desired position, press the headrest again to ensure that the headrest is locked.

Downward adjustment: Press the headrest side unlocking button, press the headrest down to the desired position, and then release the unlocking button to complete the adjustment. After adjusting to the desired position, press the headrest again to ensure that the headrest is locked.

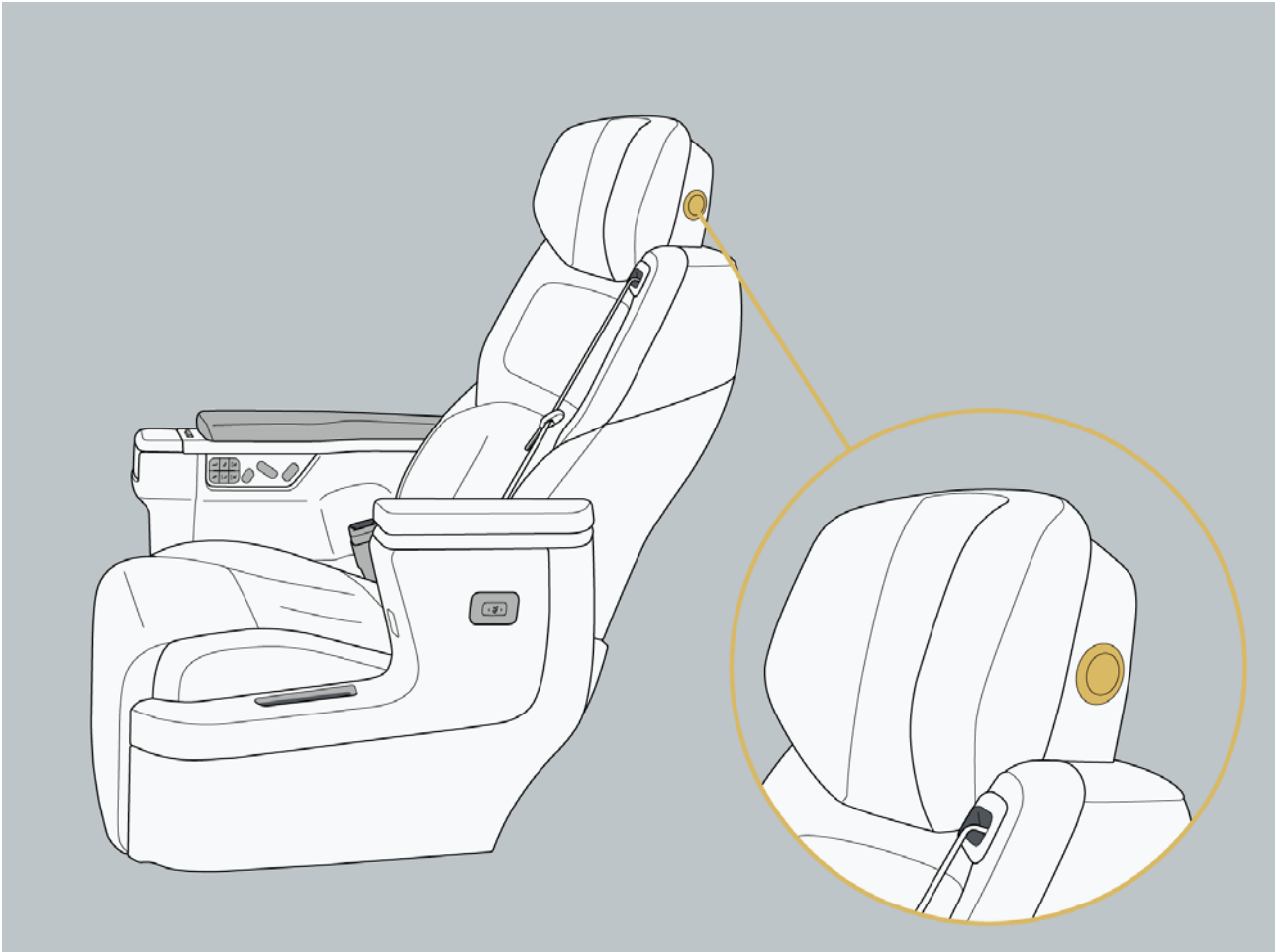

IV. Third-row headrest adjustment

Upward adjustment: Pull up the headrest to the desired position, press the headrest again after adjusting it to the desired position. Ensure that the headrest is locked.

Downward adjustment: Press the unlocking button, press the headrest down to the desired position, and then release the unlocking button to complete the adjustment. Press the headrest again after adjusting it to the desired position. Make sure that the headrest is locked.

i Hint

- When using the third-row seat headrest, adjust the headrest upwards to the use position. The lowest position is the non-use position.

6 Operation

V. Headrest disassembling

Remove the headrest: Press the unlocking button while pulling up the headrest to remove the headrest.

Install the headrest: After the headrest is aligned with the installation hole, press the unlock button and press down to the desired position. After the installation is completed, press the headrest again to ensure that the headrest is locked.

Warning

- Do not replace the headrest with the one from another vehicle.
- Do not adjust the seat headrest while driving.
- Please adjust the headrest to the appropriate position before driving. This can reduce the injury to the neck in case of a collision.

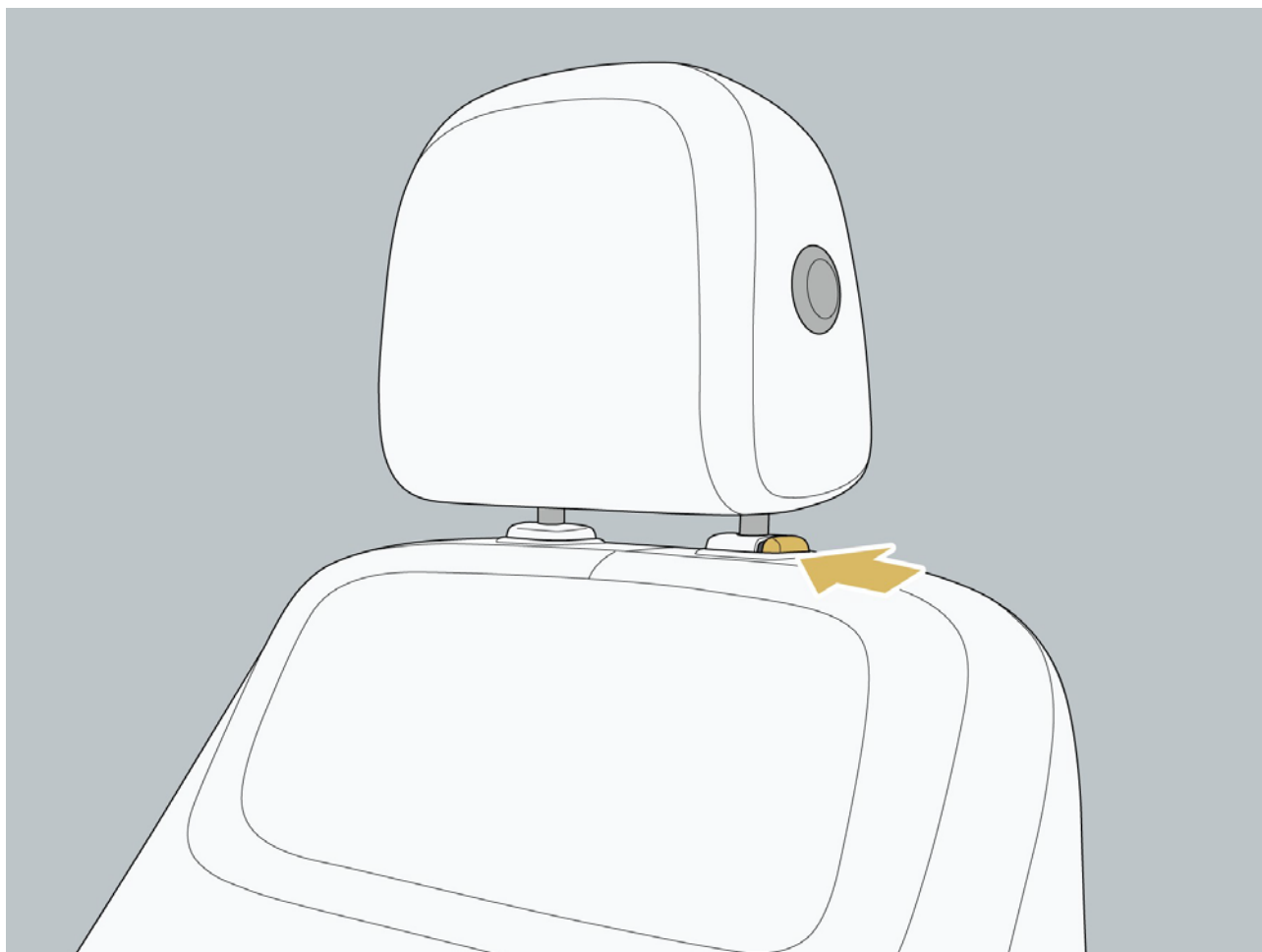

6.4 Adjustment of steering wheel and rearview mirror

6.4.1 Steering wheel

I. Adjustment of steering wheel

1. Push the steering wheel lock handle 1 down to unlock the steering wheel.
2. Adjust the steering wheel position up, down, back and forth according to the needs.
3. Pull the steering wheel lock handle 1 up to lock the steering wheel. Shake the steering wheel after adjustment is completed to ensure that the steering wheel is firmly locked.

Warning

- Do not adjust the steering wheel during driving to avoid accidents.
- After adjusting the steering wheel, be sure to lock the steering wheel to prevent it from shifting during driving.

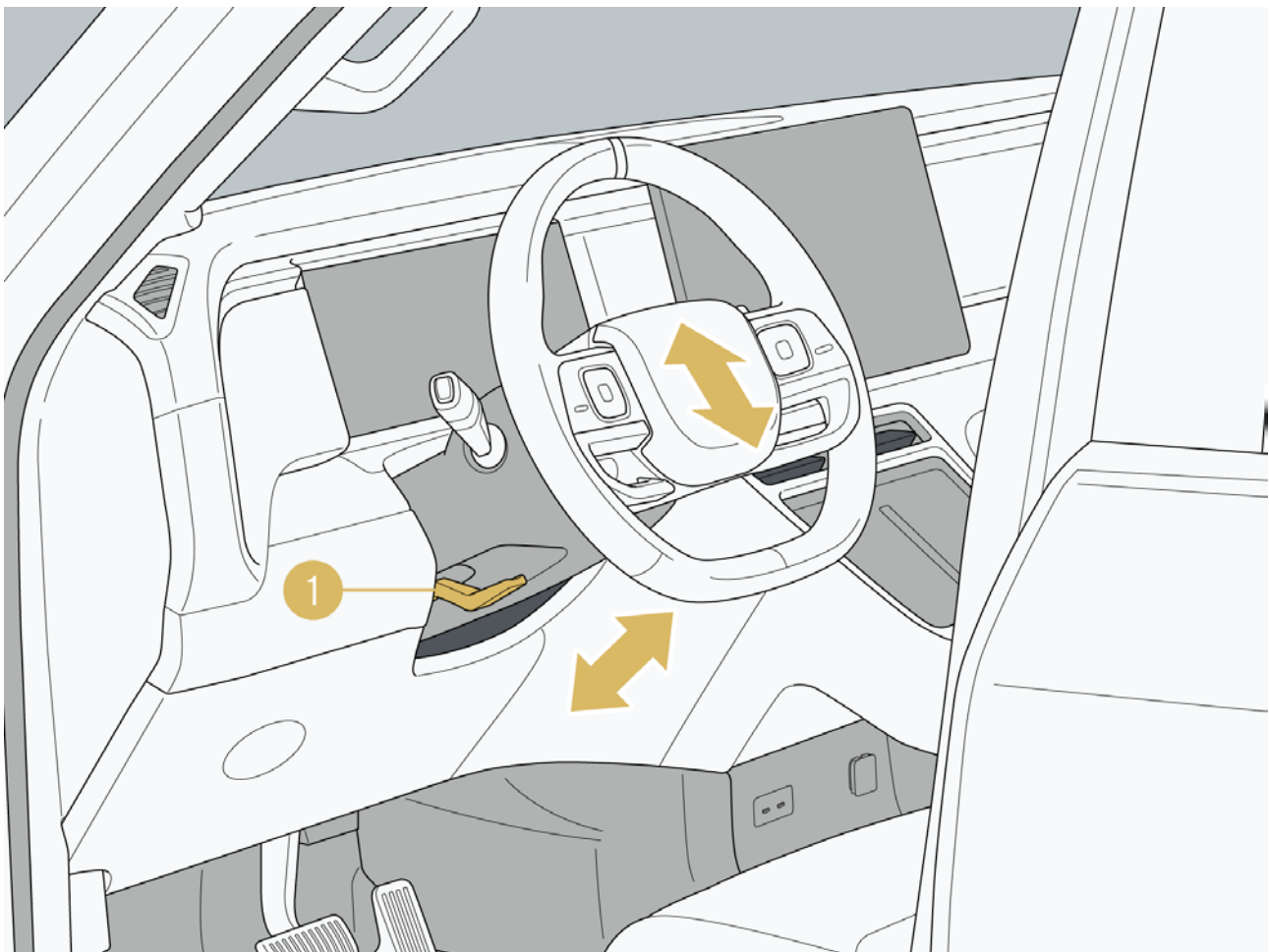

6 Operation

II. Horn

Press the horn switch in the middle of the steering wheel, and the horn will sound. Release the horn switch and the horn stops honking.

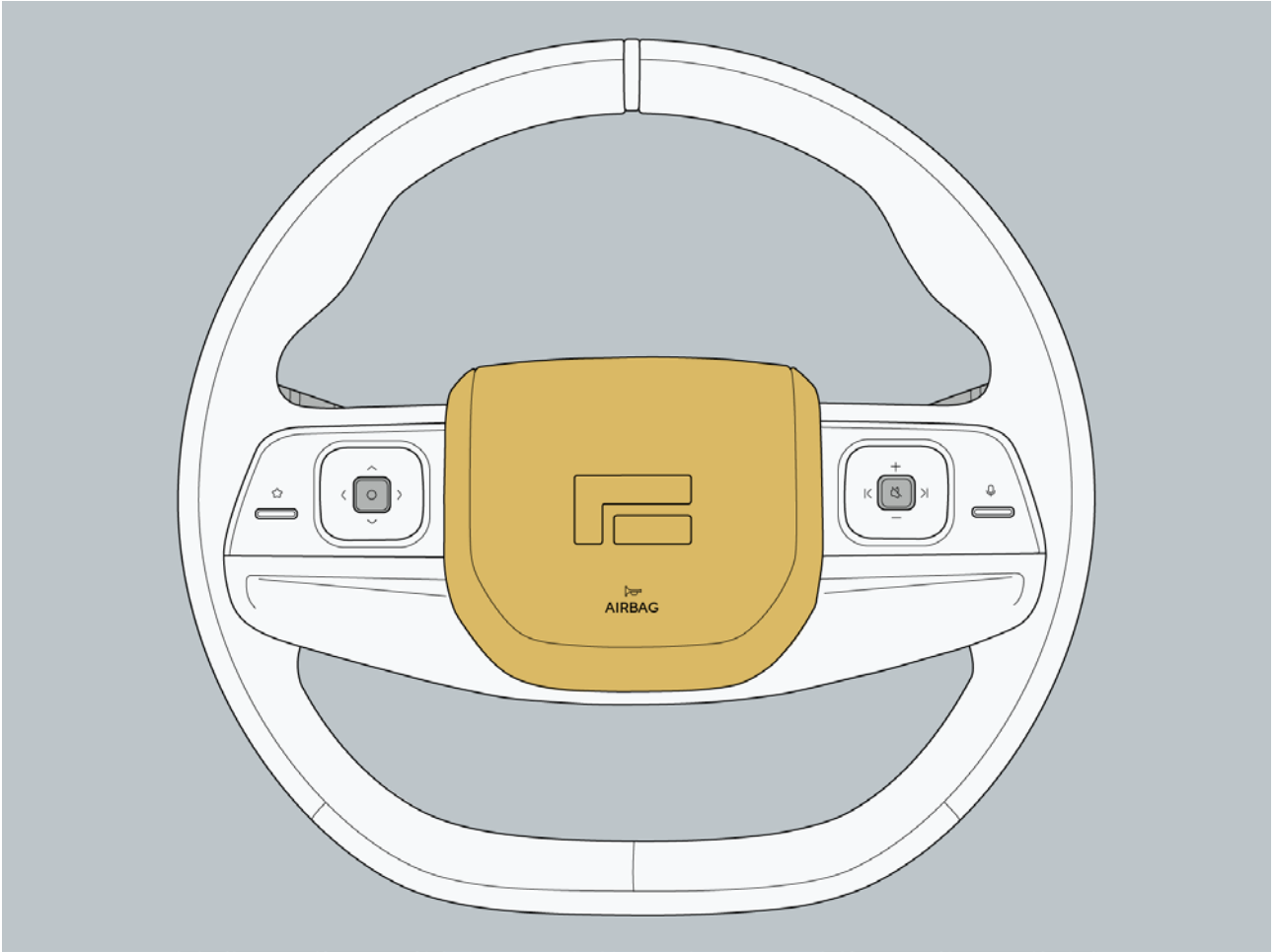

III. Steering wheel left button

1. Custom buttons: Set custom buttons by clicking “Vehicle Settings → Vehicle → Steering Wheel” through the central control screen, including: AVM (default), playback sound source switching, rear screen switch, and emergency video recording. After the setting is completed, short press the button to realize the corresponding function.
2. Confirm key: Short press to answer/hang up the phone, hide the alarm information on the instrument side, and edit the status of the entry/exit menu function. Long press to refuse to answer the phone.
3. Upper key: Short press to increase the A/C temperature; long press to switch the card function on the left side of the instrument screen.
4. Right button: Short press to increase the A/C wind speed.
5. Lower key: Short press to decrease the A/C temperature; long press to switch the card function on the left side of the instrument screen.
6. Left button: Short press to reduce the A/C wind speed.

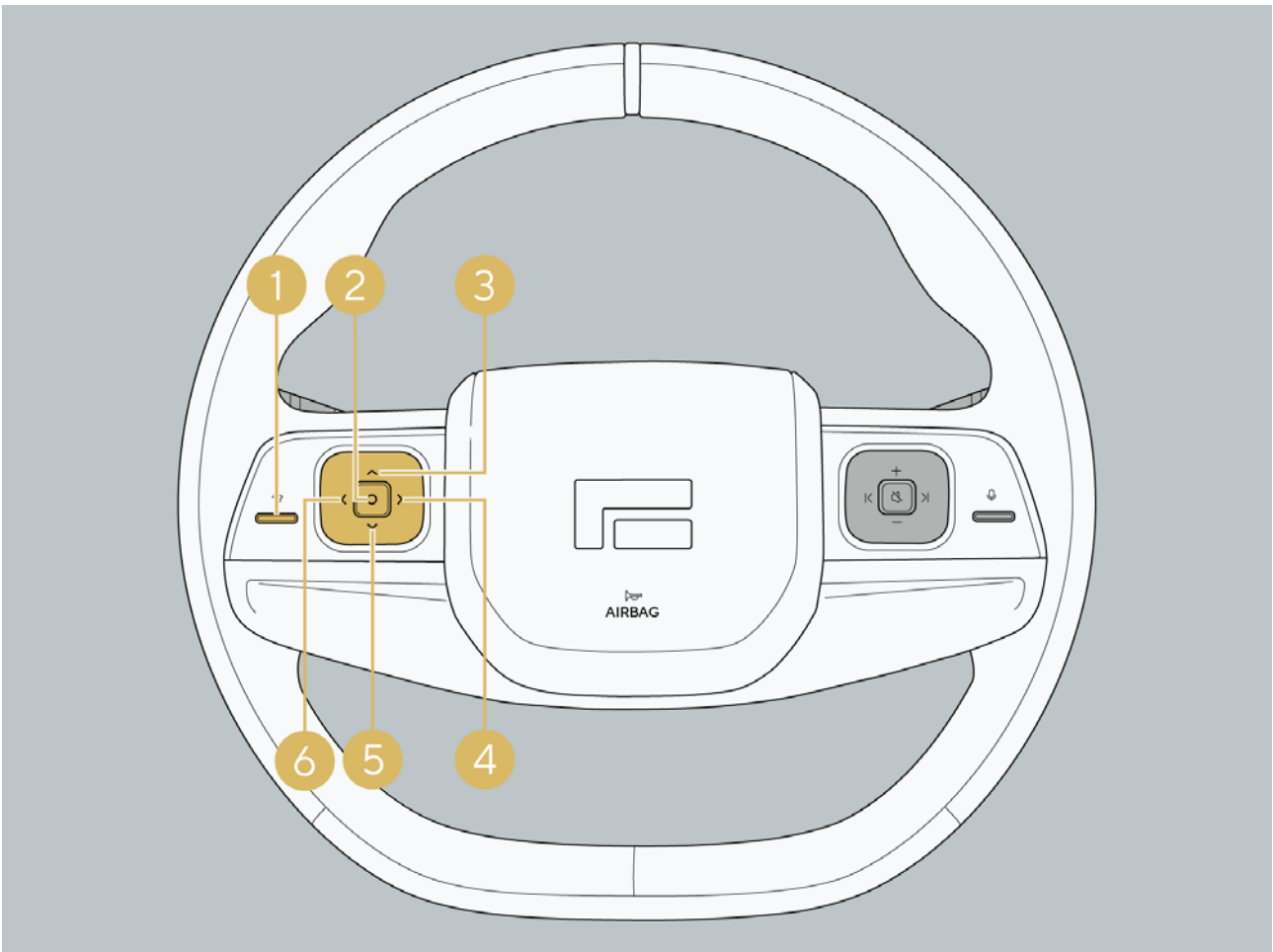

6 Operation

IV. Steering wheel right key

1. Voice key: Short press to wake up/exit the voice interaction function.
2. Mute key: Short press to mute multimedia (default), or call.
3. Volume increase key: Short press to increase the volume of multimedia/call/navigation; or adjust the function switch of the card on the right side of the instrument.
4. Left key: Short press to skip to the last track of the media music, or last video/radio channel.
5. Volume decrease key: Short press to reduce the volume of multimedia, call and navigation, or adjust the function switch of the card on the left side of the instrument.
6. Right key: Short press to skip to the next track of the media music, or next video/radio channel.

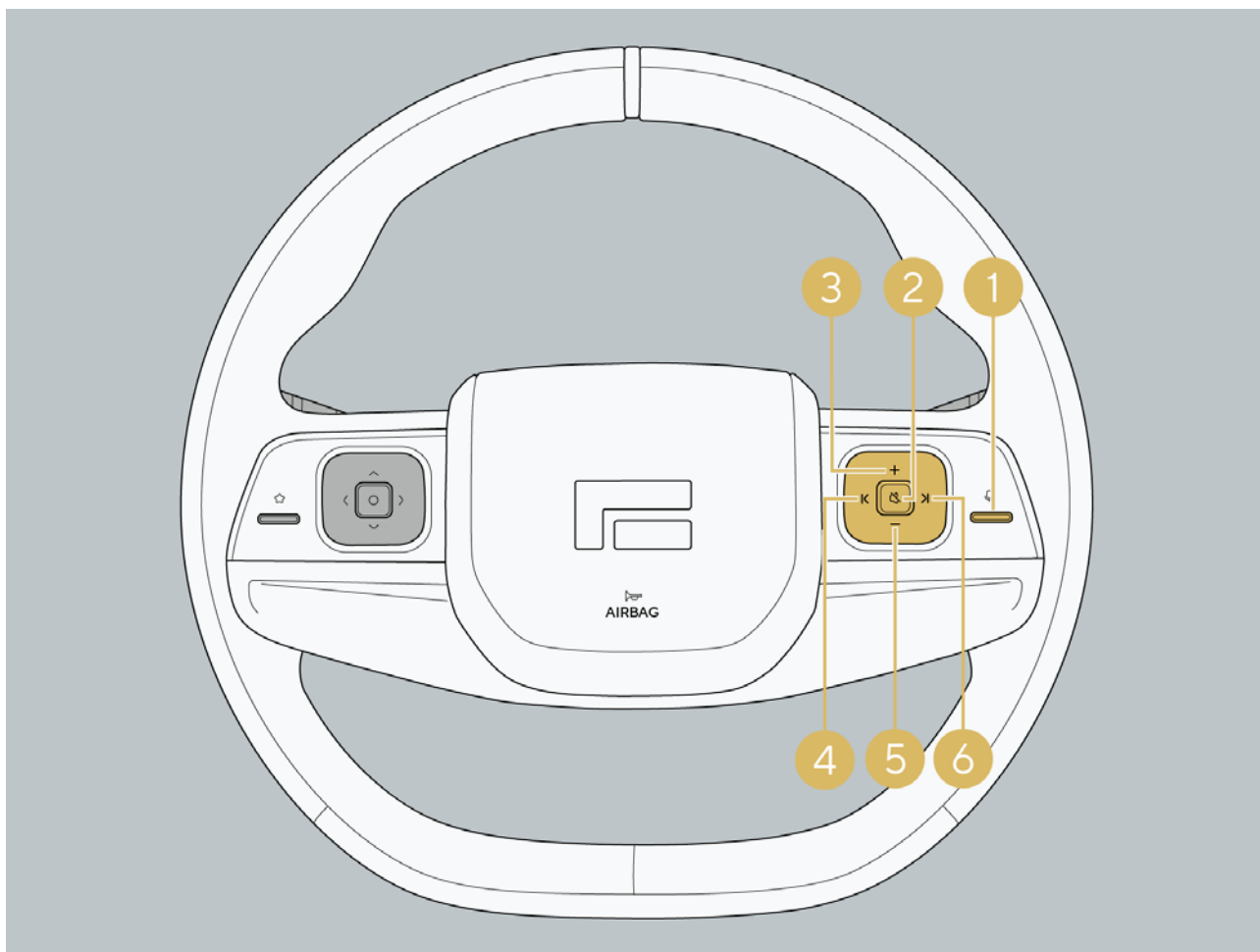

V. Restart the car infotainment system

If the vehicle infotainment system does not respond or there is an abnormality, you can try to restart the car infotainment system. You can press and hold the Custom Button 1 and Voice Button 2 simultaneously (for about 10s) to restart the central control screen and instrument screen.

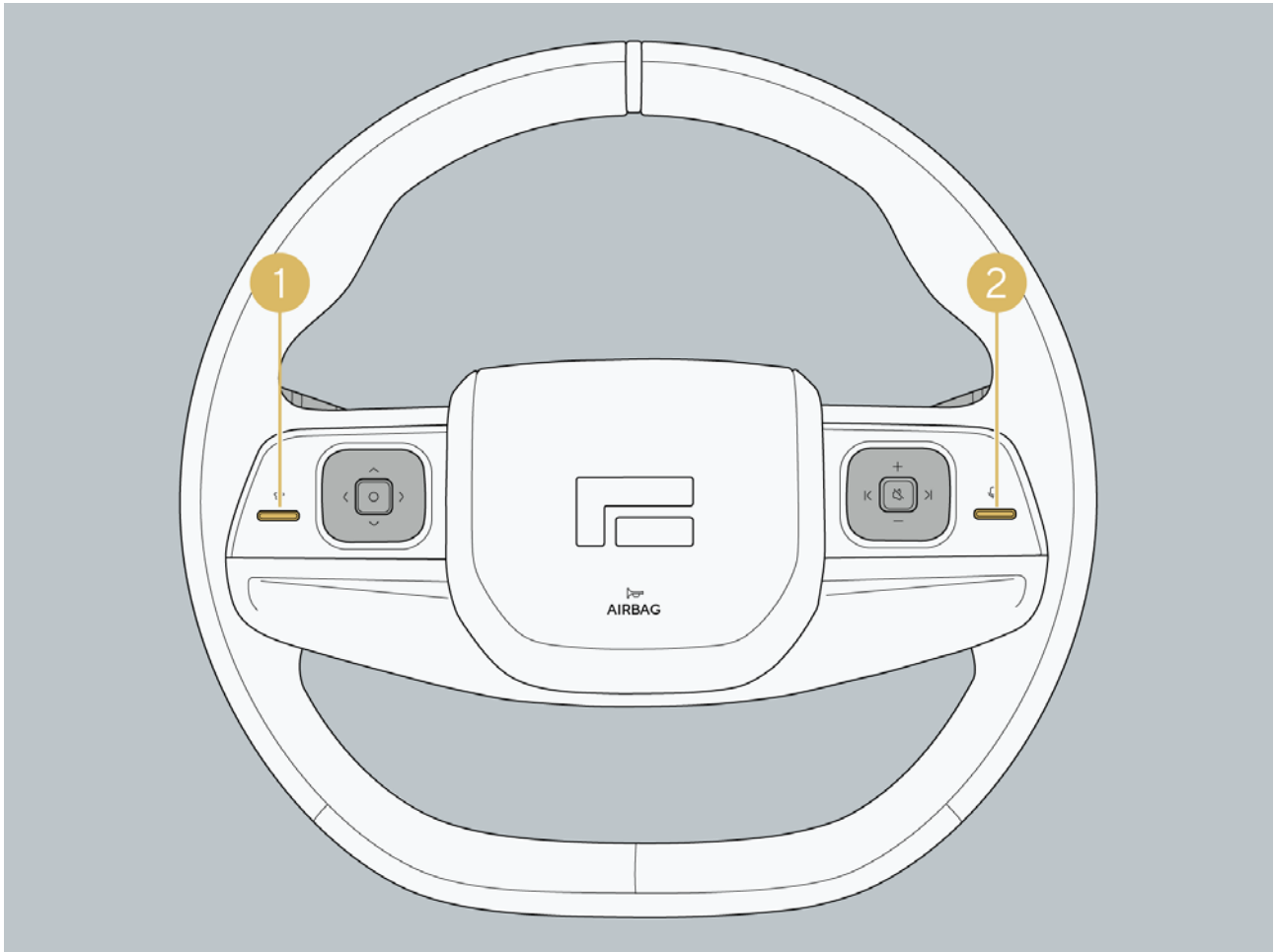

6 Operation

6.4.2 Interior rearview mirror

I. Adjust the interior rearview mirror

According to your own situation, manually adjust the angle of the inner rearview mirror until you can observe the road conditions behind the vehicle through the inner rearview mirror.

Warning

- Do not install items or trims that affect the line of sight around the interior rearview mirror. This will avoid affecting the driver's observation of road conditions.
- Do not adjust the interior rearview mirror during driving. This will avoid loss of control of the vehicle due to distracting, resulting in casualties or vehicle damage.

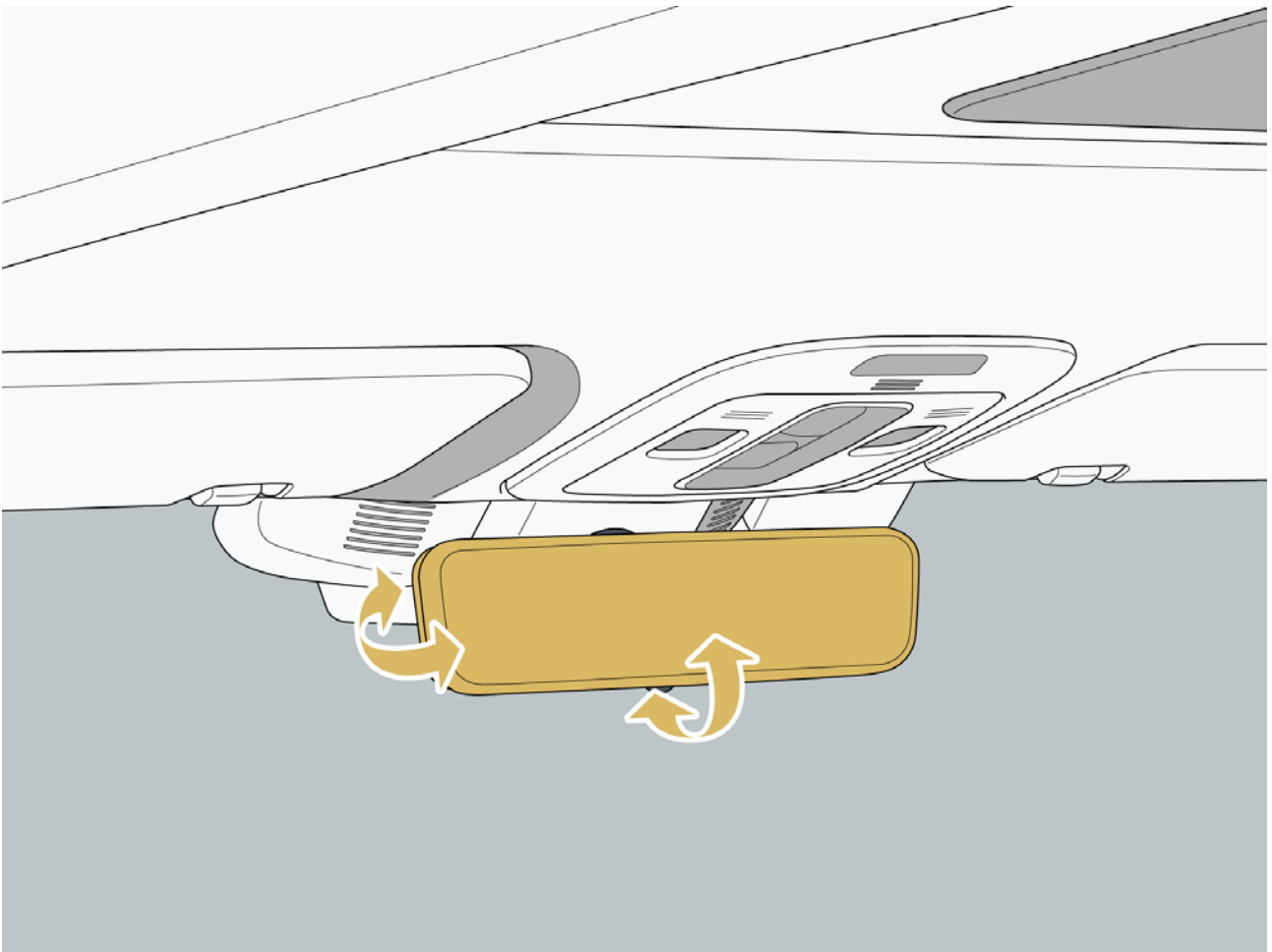

II. Interior rearview mirror anti-dazzling

The inner rearview mirror has an automatic anti-dazzling function. When strong light from behind (such as the high beam of the vehicle behind) shines on the inner rearview mirror, it will automatically dim the mirror surface, thereby reducing the impact of the strong light on the driver.

III. Turn on or off the anti-dazzling function

To turn on or off the anti-glare function, click "Vehicle Settings → Accessories → Streaming Media Rearview Mirror → Anti-Dazzling" on the central control screen.

Hint

- Rear passengers or raised rear headrests may affect the automatic anti-dazzling function of the rearview mirror.
- When the vehicle switches to R gear, the automatic anti-dazzling function will be turned off, allowing you to better observe the road conditions behind.

IV. Stream media rearview mirror

The streaming media rearview mirror function takes pictures of the environment behind the vehicle through the rearview camera and presents the images in real time on the display screen of the inner rearview mirror, increasing the driver's visual angle and avoiding the danger caused by the inability to see the environment behind the vehicle due to the opening of the rear screen and the rain and fog on the rear windshield.

1. Turn on or off streaming media

Click "Vehicle Settings → Accessories → Streaming Media Rearview Mirror → Working Mode" on the central control screen, and select "Streaming Media Mode" to start streaming media. Select "Mirror Mode" to turn off the streaming media mode.

2. Adjust the streaming media interior rearview mirror

Backlight brightness adjustment: Slide the slider left or right to adjust the backlight brightness. Click "Auto", and the streaming media will automatically adjust the backlight brightness according to the external brightness.

Display height adjustment: Slide the slider left or right to adjust the display height. Click "Standard", and the streaming media will display the height adjustment to the system default position.

Screen size adjustment: Slide the slider left or right to adjust the display screen size.

Color temperature adjustment: You can choose cold color temperature, standard color temperature, and warm color temperature.

V. Functional limitation

Stream media interior rearview mirrors may not function or display a clear image if:

- The sun reflects or the headlamps of the rear car cause dazzling, or obstacles block the view.
- The camera lens is clogged by dust, snow, or other debris. Clean the lens with a soft, damp cloth.
- The vehicle was damaged and the position and installation angle of the camera changed.

6 Operation

Warning

- If there is any dirt on the rearview camera, please clean it in time.
- If the stream media function fails, please switch to the traditional rearview mirror for use. At the same time, contact ROX Service Center.
- The stream media function cannot replace the driver's judgment of the external situation. Do not only observe the interior rearview mirrors when driving or parking. Under any circumstances, the driver should be responsible for the safety of the vehicle and observe the surrounding conditions of the vehicle at any time.

6.4.3 Exterior rearview mirror

The rearview mirror is crucial for driving safety. You can use the rearview mirror control button on the driver's door trim to adjust the external rearview mirror.

I. Adjust the exterior rearview mirror

1. Press the left or right selection button on the external rearview mirror and select the one that needs to be adjusted.

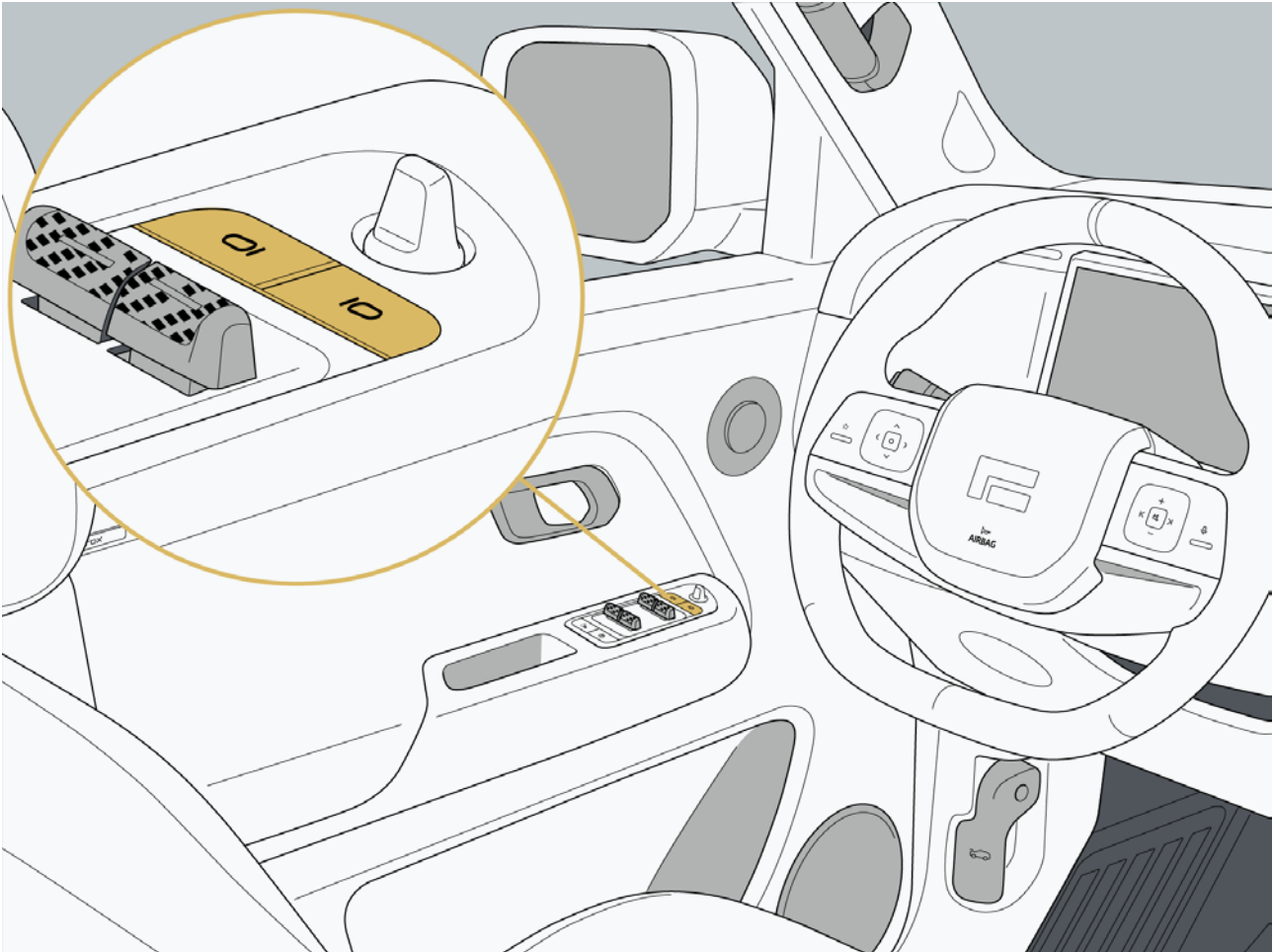

6 Operation

2. After pressing the corresponding rearview mirror adjustment button, adjust the angle of the external rearview mirror through the circular button.

Warning

- To avoid dangerous driving and accidents, please adjust the external rearview mirrors when the vehicle is stationary.
- Do not drive your vehicle when the exterior mirrors are not adjusted to the appropriate position.

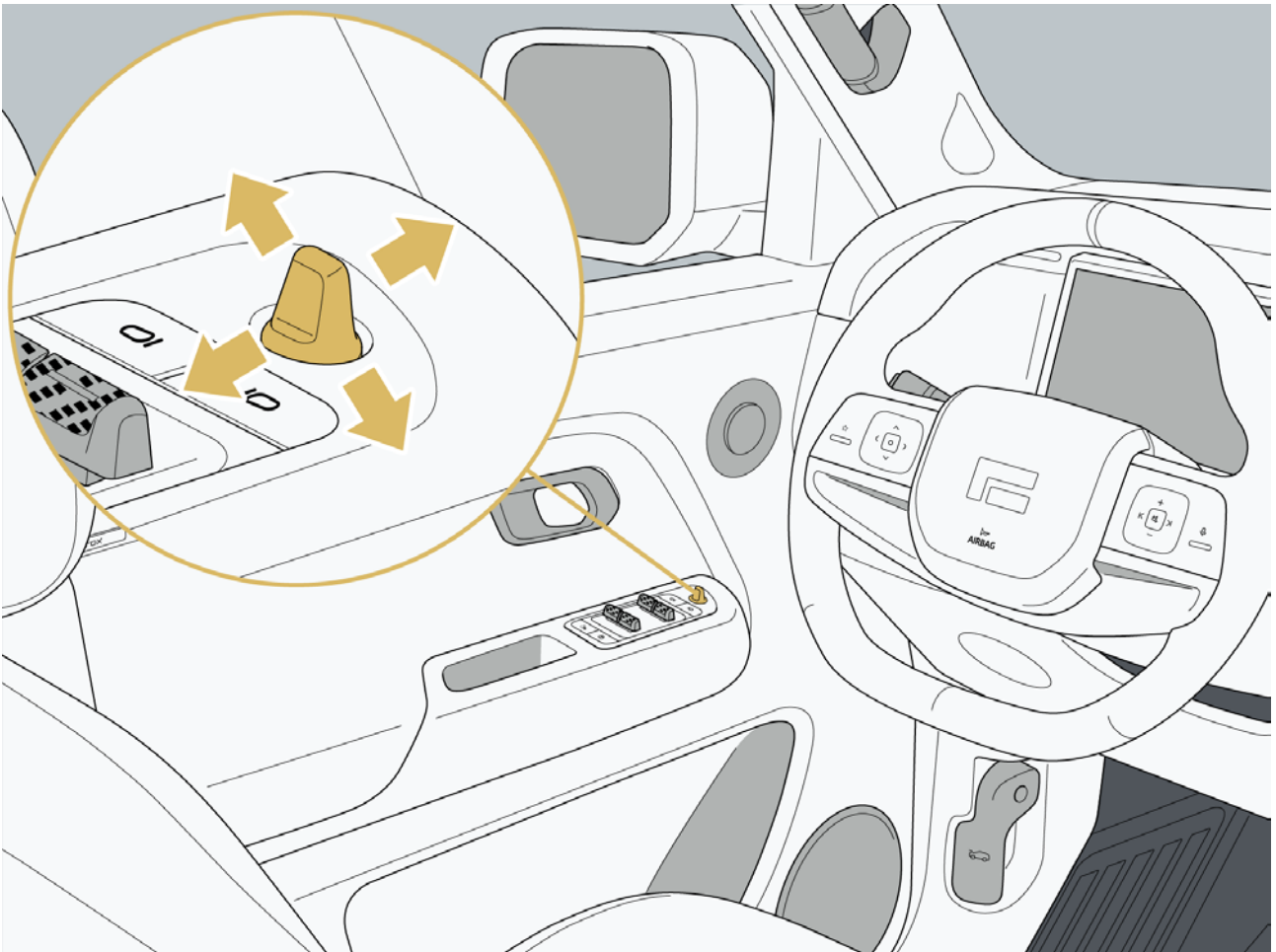

II. Unfold and fold the exterior rearview mirror

1. Manual folding and unfolding

Press the left and right selection buttons of the external rearview mirror simultaneously to fold the external rearview mirror. Press it simultaneously again, and the external rearview mirrors will unfold.

Hint

- When the vehicle speed is greater than 15 km/h, the operation of the electric folding exterior rearview mirror is invalid.

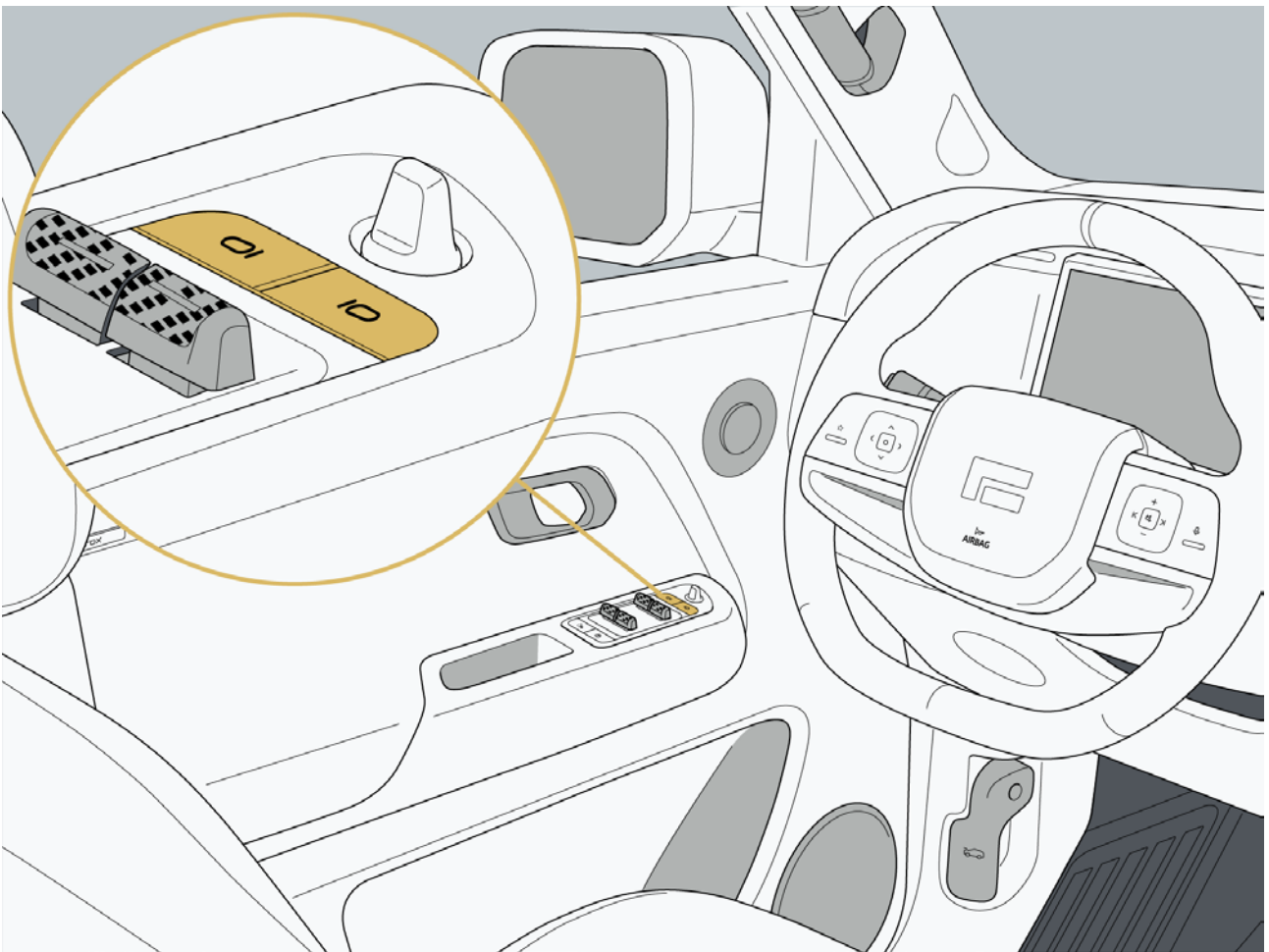

2. Auto folding and unfolding

Click "Vehicle Settings → Vehicle → Rearview Mirror → Lock → Auto Fold Rearview Mirror" through the central control screen, to set the activation and deactivation of the auto fold function for the exterior rearview mirror.

Auto folding: When the door is locked from outside, the exterior rearview mirror automatically folds.

Auto unfolding: When the door is unlocked from outside, the exterior rearview mirror automatically unfolds.

6 Operation

Warning

- Do not touch the exterior rearview mirror during movement to avoid pinching.

3. Folding and unfolding through the central control screen

Click "Vehicle Settings → Vehicle → Rearview Mirror → Fold Rearview Mirror" through the central control screen, to set the activation and deactivation of the folding or unfolding for the exterior rearview mirror.

III. Reversing exterior rearview mirror tilt down

1. Turning on/off reversing exterior rearview mirror tilting down

Click "Vehicle Settings → Vehicle → Rearview Mirror → Reverse Auto Tilt Down Rearview Mirror" through the central control screen, to set the activation and deactivation of the reversing exterior rearview mirror tilt down function to turn off, only left side, only right side or turn on both sides.

2. Storage of exterior rearview mirror tilt down position

After the function setting is activated, switch to R rear to manually adjust the exterior rearview mirror on the corresponding side. After the adjustment is completed, the system will automatically store this position as the exterior rearview mirror tilt down position.

3. Activating reverse exterior rearview mirror tilt down function

After the function setting is activated, when the vehicle gear is switched to R position, the exterior rearview mirror on the corresponding side will automatically tilt down to the storage position.

Hint

- During the activation process of the reversing exterior rearview mirror tilt down function, if the vehicle speed is greater than 15 km/h, the vehicle power supply exits the "READY" mode, or when operating the exterior rearview mirror adjustment switch, the reversing exterior rearview mirror tilt down function will automatically exit.

IV. Heating of external rearview mirror lenses

The exterior rearview lenses come with a heating function. The function is used to heat the left and right exterior rearview lenses to quickly dry water or snow stains in rainy and snowy days.

1. Manual heating

Click the "Rear Defrost" icon through the A/C control interface of the central control screen to manually turn on/off the exterior rearview mirror/rear window heating function.

2. Auto heating

When the heating function of the exterior rearview mirror is turned off, and the wiper gear is switched to low/high speed gear, or the wiper gear is switched to automatic gear for wiping, the heating function of the rear windows and the exterior rearview mirror is automatically turned on. When the wiper gear is switched to "OFF" position, or the wiper stops wiper with the gear in automatic position, the heating

function of the rear window and the exterior rearview mirror is automatically turned off. The current power-on cycle only performs automatic heating once.

Warning

- Do not touch the exterior rearview mirror lenses during heating to avoid burns.

Hint

- The heating function of the exterior rearview mirror and rear window will be automatically turned off after 15 min.

V. Auto anti-dazzling of exterior rearview mirror

When the vehicle power supply is in the "READY" mode, the mirror surface of the exterior rearview mirror will automatically dim according to the dazzling degree of the rear car lamps.

6 Operation

6.5 Memory function

6.5.1 Driver memory function

The driver can quickly obtain the relevant driver's seat position and exterior rearview mirror position through memory position function, which is convenient for the driver to quickly choose a comfortable driving position.

I. Memory position setting

When the user adjusts the position of the driver's seat or the exterior rearview mirror, the central control screen will automatically pop up the memory position setting interface. Click any sitting posture icon on the setting interface to save the mirror position information of the current driver seat and the exterior rearview mirror to the corresponding memory position.

II. Memory position call-out

Click the corresponding sitting posture icon through the central control screen to call out the corresponding memory position information.

Warning

- It is forbidden to call out the memory position during the driving to prevent accidents.

Hint

- During the memory position call-out process, such as manually adjusting the driver's seat or exterior rearview mirror, the memory position call-out of the corresponding function will be interrupted.

6.5.2 Driver welcome seat

Click "Vehicle Settings → Vehicle → Seat → Driver welcome seat" through the central control screen, set activation or deactivation of the driver welcome function. It is activated by default.

If the vehicle is in P gear and the seat belt of the driver is untied, when the door on the driver's side is opened, the driver's seat will automatically adjust down to the welcome position for you to get out of the car. When you get in the car and close the door, the driver's seat automatically returns to its original position.

When using seat memory to adjust the memory position or manually adjusting the seat position, the vehicle will record this position as your current driving preference position. When you open the door again to prepare for driving, the seat will automatically return to the driving preference position you set last time.

Hint

- When the driver welcome seat function is working, if the seat position is manually adjusted, the function will stop working.

6 Operation

6.6 Window and sunshade

6.6.1 Window

You can open or close the windows through the window button on the driver's door, the remote key or the central control screen.

I. Window button

You can use the window buttons on the driver's door to operate all the windows, and passengers can use the window buttons on the door of their side to operate the corresponding windows.

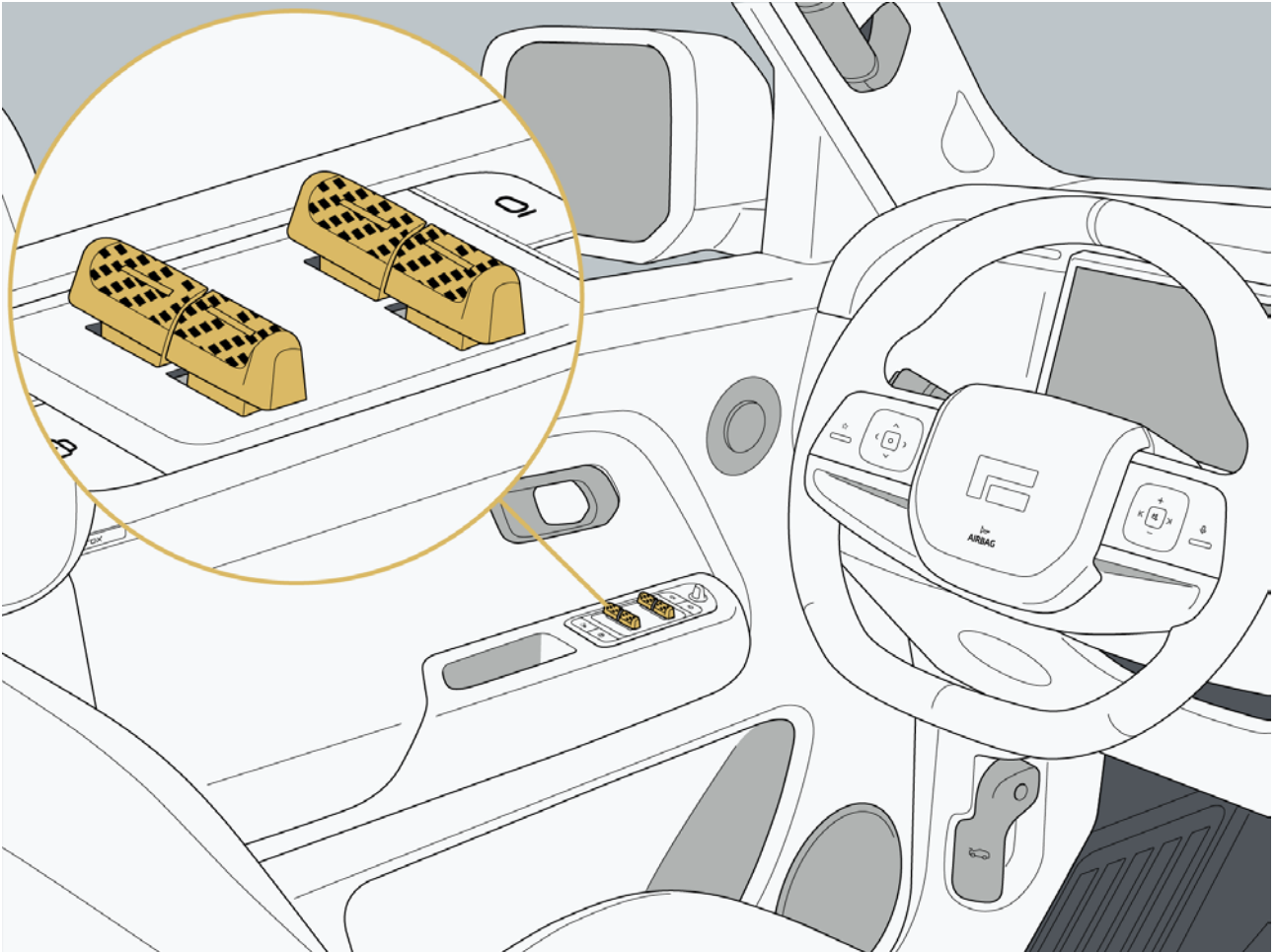

II. Open and close the window

- First gear: When you need to open some windows, you can move the window button forward and release it when the window is lowered to the desired position; When closing, move the window button backward to raise the window to the desired position and release it.
- Second gear: Move the window button forward to the limit position and release it, the window will automatically lower to the fully open position; Move the window button backward to the limit position and release it, the window will automatically rise to the fully closed position; During automatic up and down of window, move the corresponding button forward/backward again to stop the window movement.

Caution

- After the child safety lock is activated, the corresponding window switch on the rear door cannot control the window. Avoid children or other occupants from mistakenly operating the windows.

Hint

- In low-temperature conditions, the window glass may freeze, making it difficult to lift and lower. At this time, thawing treatment should be carried out first.

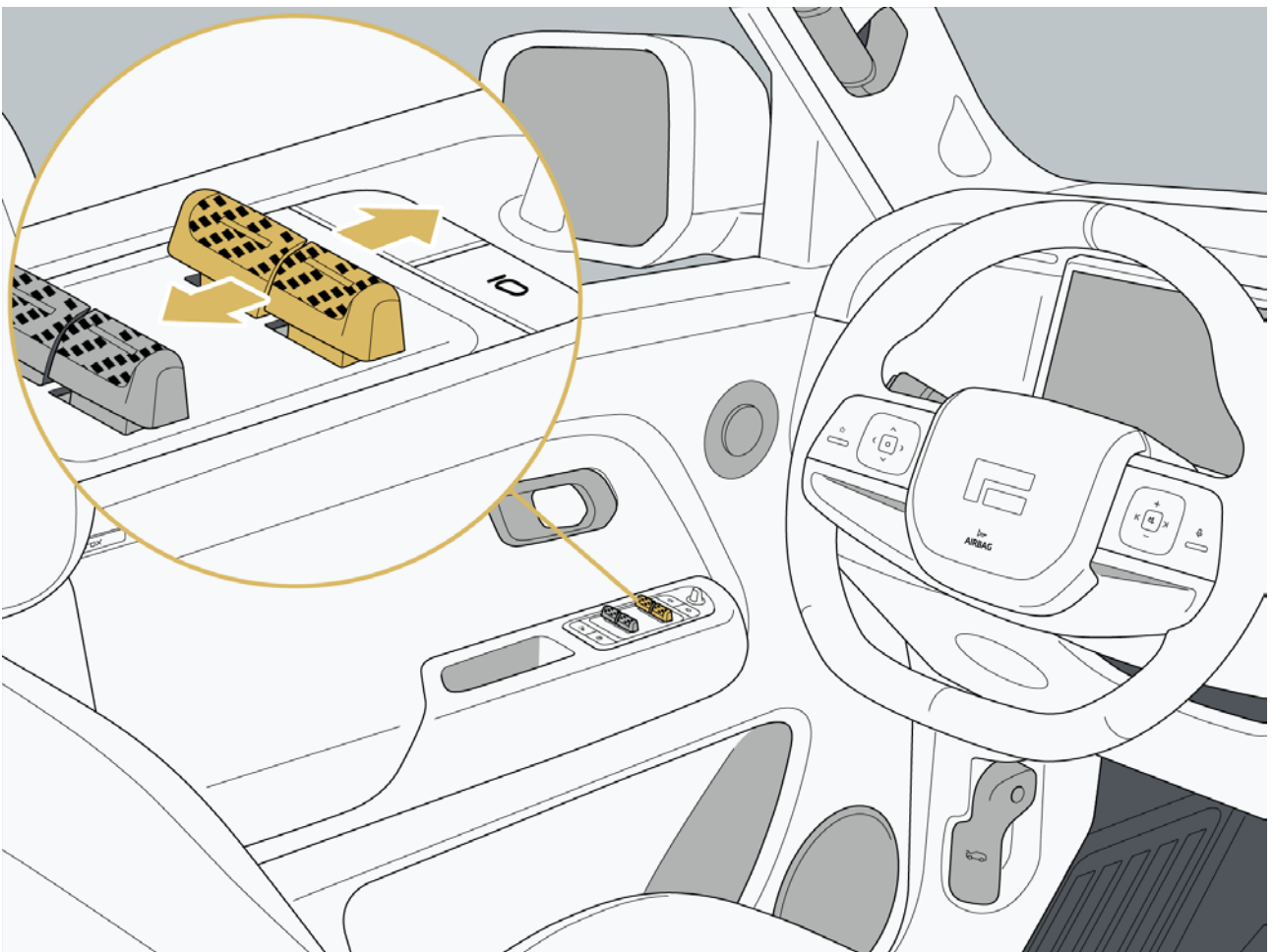

6 Operation

III. Control the window through the remote Key

1. Long press the remote key unlock button to open the window. When opening the window, release the unlock button and the window will stop opening.
2. Long press the remote key lock button to close the window. When closing the window, release the lock button and the window will stop closing.

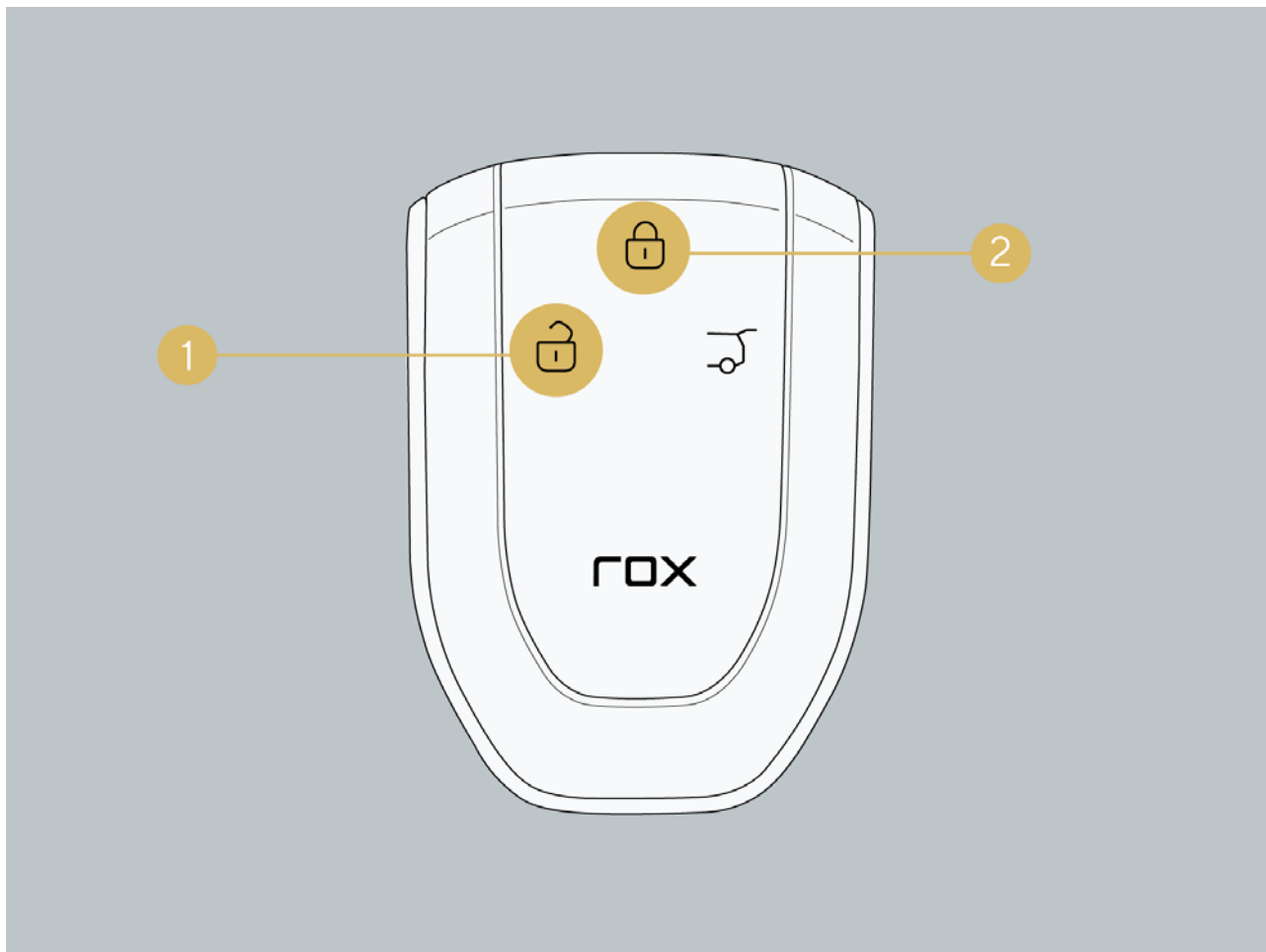

Warning

- When closing the window with the remote key, be sure to confirm that there are no obstacles in the movement area of the window before operating to avoid being pinched or damaging the car.

IV. Automatically close the window in rainy day

With the complete vehicle in alarm mode, if any window is not closed, when the vehicle senses rain, the window will automatically close.

Caution

- This function does not work in all cases (for example, when the sensor fails or the auto window lift function fails, the window will not be closed). Do not rely on this function to close the window to avoid property loss.

V. Automatically close the window by locking the car

If any window is not closed, when the vehicle is locked from outside, the window will automatically close. You can click "Vehicle Settings → Vehicle → Door/Window Lock → Auto Window Close on Lock" through the central control screen to set the activation and deactivation of the auto window closing function.

Warning

- After the auto window close on lock function is activated, do not leave children or pets in the car after locking the car to avoid accidents.
- After the auto window close on lock function is activated, note that there are no obstacles in the movement area of the window when locking the car to avoid unnecessary losses.

VI. Window ajar

The windows are equipped with an ajar function. When the window encounters obstacles or the window is restricted to move during the closing process, the window will stop moving or reverse moving for a certain distance.

Warning

- Do not test the window ajar function with various items to avoid unnecessary losses.
- Although the window has ajar function, it is still necessary to make sure that the closed area of the window is free of obstacles. In special cases (such as thin or soft obstacles), it is impossible to ensure that the window ajar function can be activated.

VII. Window initialization

If the auto window lift or ajar function fails, carry out the initialization operation as follows:

1. Pull the window button backward. The window will step up until the window is completely closed.
2. Pull the window button forward until the window is fully open. The initialization is completed.

Warning

- Before closing the windows, the driver must ensure that all occupants (especially children) do not lean any part of their bodies out of the windows. Otherwise, serious injury may be caused.

6 Operation

- Do not leave children alone in the car. Children may misoperate window switches.
- If the vehicle is unattended, make sure that the vehicle is powered off when leaving the vehicle to ensure that the windows are inoperable.

6.6.2 Sunshade

I. Front sunshade control

1. Sunshade switch control

Open: Short press the back of the front sunshade switch, the front sunshade will stop moving after opening for a short distance. Press the back of the front sunshade switch for a period of time, the front sunshade will automatically move to the fully open position.

Close: Short press the front of the front sunshade switch, the front sunshade will stop moving after closing for a short distance. Press the front sunshade switch for a period of time, the front sunshade will automatically move to the fully closed position.

Hint

- During the automatic movement of the front sunshade, press the front sunshade switch again, the front sunshade will stop at the current position.

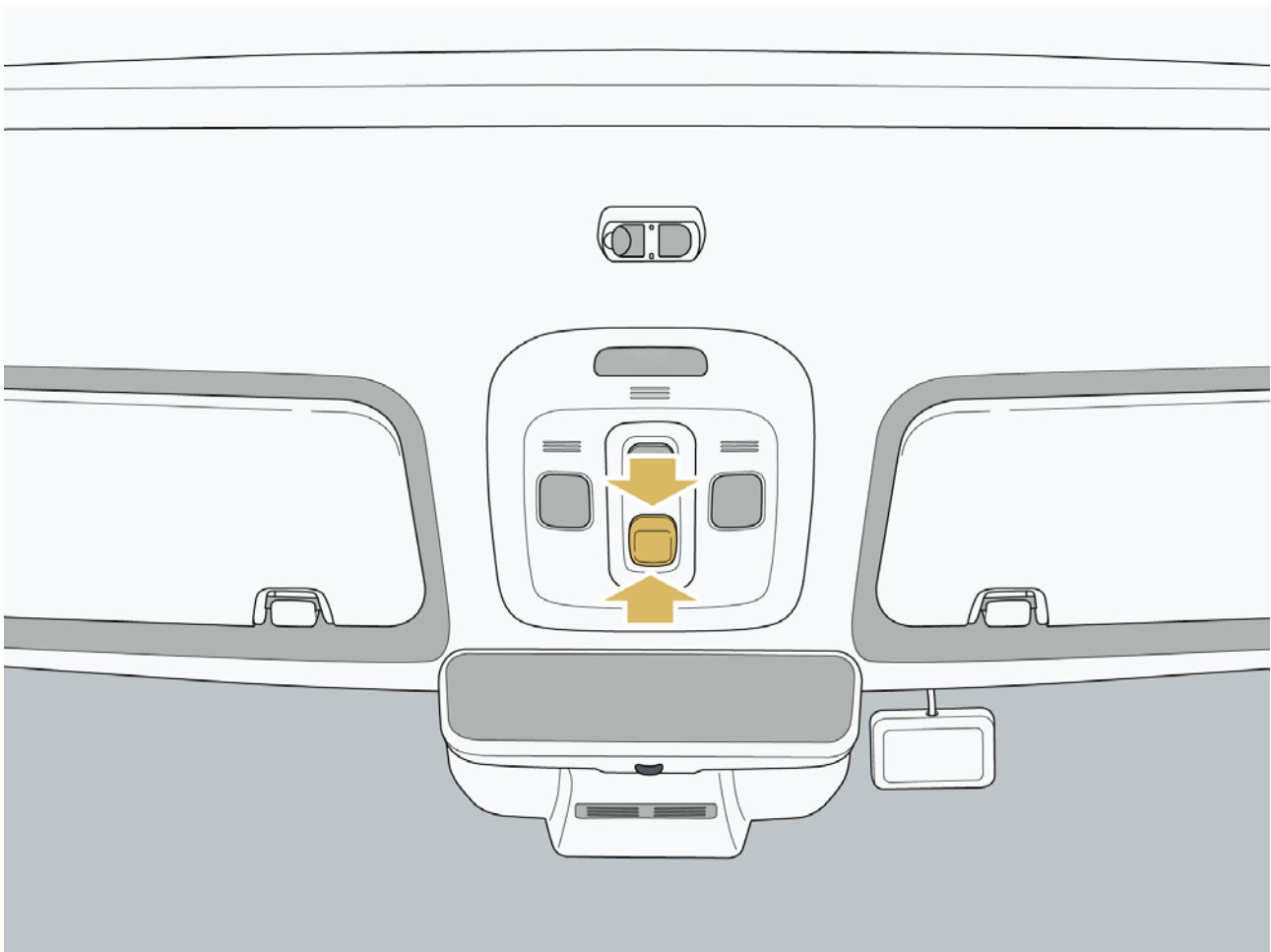

2. Remote Key control

When the vehicle power supply is in non "READY" mode, the front sunshade can be opened and closed by the remote key unlocking/locking button.

6 Operation

Open: Long press the remote key unlocking button, the front sunshade will automatically move to the fully open position.

Close: Long press the remote key locking button, the front sunshade will automatically move to the fully closed position.

II. Rear sunshade control

1. Rear sunshade switch control

Open: Short press the back of the rear sunshade switch, the rear sunshade will stop moving after opening for a short distance. Press and hold the back of the rear sunshade switch for a period of time, the rear sunshade will automatically move to the fully open position.

Close: Short press the front of the rear sunshade switch, the rear sunshade will stop moving after closing for a short distance. Press and hold the rear sunshade switch for a period of time, the rear sunshade will automatically move to the fully closed position.

Hint

- During the automatic movement of the rear sunshade, press the rear sunshade switch again, the rear sunshade will stop at the current position.

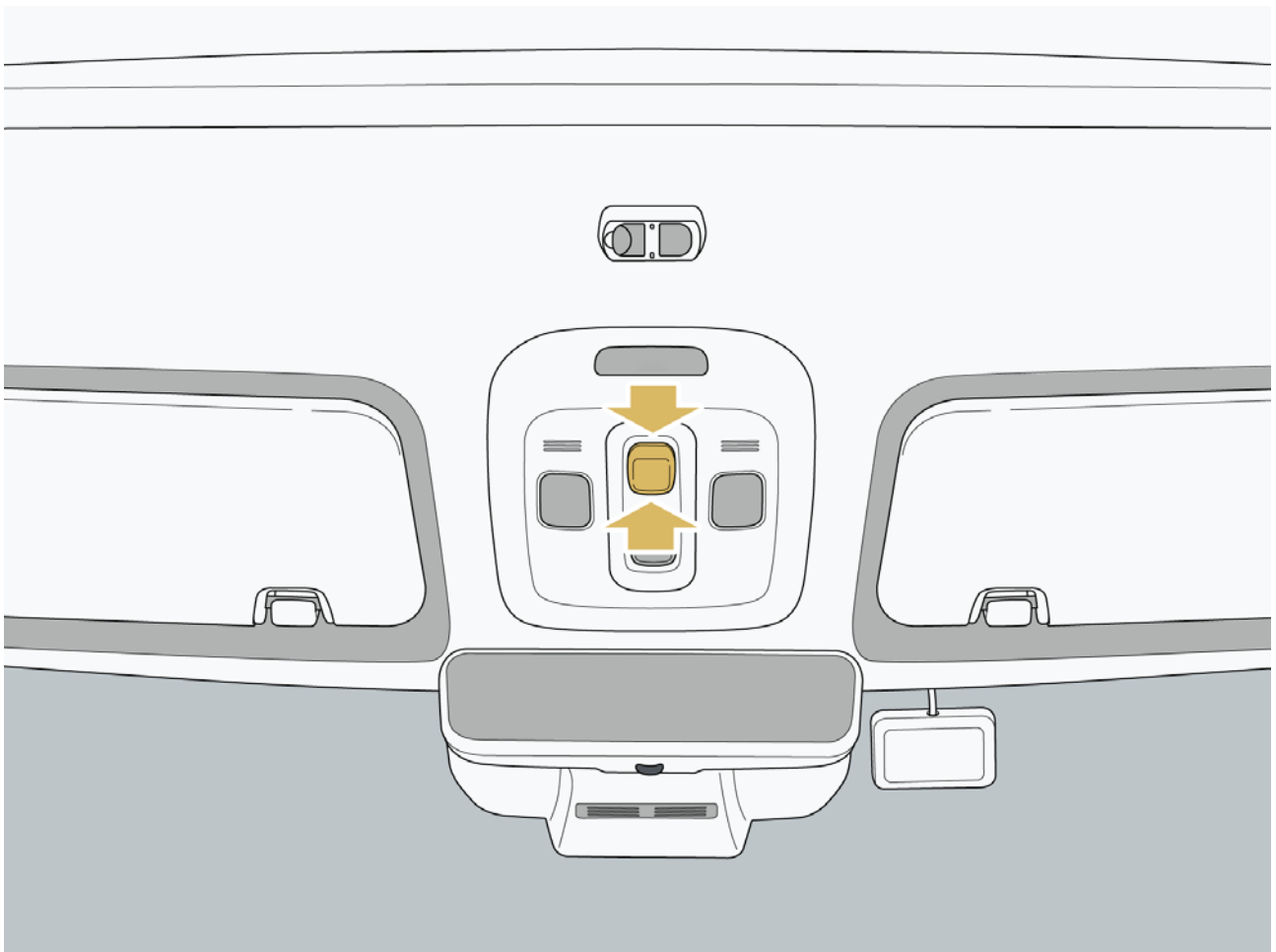

2. Remote Key control

When the vehicle power supply is in non "READY" mode, the rear sunshade can be opened and closed by the remote key unlocking/locking button.

6 Operation

Open: Long press the remote key unlocking button, the sunshade will automatically move to the fully open position.

Close: Long press the remote key locking button, the sunshade will automatically move to the fully closed position.

III. Automatically close the sunshade by locking the car

Click "Vehicle Settings → Vehicle → Door/Window Lock → Auto Window Close on Lock" to set the activation and deactivation of the auto window close on lock function. After activation, the front and rear sunshades will automatically close when the vehicle is locked.

IV. Sunshade ajar

The front/rear sunshades are equipped with an ajar function. When the sunshade encounters obstacles or the sunshade is restricted during the closing process, the sunshade will stop moving or reverse moving for a certain distance.

Warning

- Do not test the sunshade ajar function with various items.

V. Sunshade self-learning

1. Press and hold the sunshade close button until the sunshade is fully closed.
2. After the sunshade is fully closed, press and hold the sunshade close button for more than 10 s.

Warning

- When using the remote key to close the sunshade, note that there are no obstacles in the movement area of the sunshade to avoid unnecessary losses.
- After the auto sunshade close on lock is activated, note that there are no obstacles in the movement area of the sunshade when locking the car from outside to avoid unnecessary losses.

Caution

- During the initialization operation, keep the sunshade close button pressed all the time. If it is released halfway, the initialization fails, and the above operations need to be carried out again.

6.7 A/C system

6.7.1 Front A/C system

Front A/C system

Click the A/C icon on the central control screen to open the control A/C interface. Click the collapse icon in the upper left corner or click the air conditioner icon in the bottom function bar to collapse the air conditioner control interface.



I. Front A/C switch

Click the "Switch" icon through the A/C control interface to turn on the front A/C. Click again to turn off the front A/C.

When the front A/C is turned off, the front A/C can be turned on by the following operations:

- Adjust the air volume.
- Turn on A/C auto mode.
- Adjust the blowing mode.
- Activate windshield defrost and defog mode.
- Adjust the temperature.

II. Temperature setting

In the A/C control interface, slide up/down to set the temperature value. Set the temperature of the driver and the front passenger respectively. Each slide can increase or decrease the temperature by 0.5°C. Fast slide can quickly adjust the temperature. The set temperature is adjustable within LO (16°C) ~ Hi (28°C).

6 Operation

III. Refrigeration mode

Click the "AC" icon through the A/C control interface to turn on the refrigeration mode. Click again to turn off the refrigeration mode.

IV. Air speed adjustment

When adjusting the air speed, slide the "Wind Speed" icon left/right through the A/C control interface. Slide left to reduce the air volume, and slide right to increase the air volume. When turned on, the default is the last set value. The maximum air speed can be adjusted to level 9.

V. Front-row blowing mode

Click the "Blowing Mode" icon on the central control screen. Blowing modes can be combined in different combinations. There are five blowing modes: blowing face, blowing foot, defrosting, blowing face and foot and blowing foot and defrosting.

VI. Front-row temperature synchronization

Click the "Sync" icon through the A/C control interface to turn on the synchronization mode.

When the front-row temperature synchronization is turned on, the temperature of the front passenger's A/C is immediately synchronized with the temperature at the driver. If the temperature is synchronously turned on, when the driver adjusts the A/C temperature, the temperature of the front passenger's A/C changes with the temperature at the driver. When the front passenger adjusts the A/C temperature, the temperature at the driver remains unchanged. At the same time, the temperature synchronization mode is turned off.

VII. Air circulation

A/C circulation includes three modes: internal circulation, external circulation and auto circulation. The mode is selected or switched through the A/C control interface.

- Internal circulation: When the air quality outside the vehicle is poor, you can turn on the internal circulation mode. The system will prevent external dust and harmful gases from entering, ensuring continuous air circulation inside the vehicle.
- External circulation: When the air quality outside the vehicle is good, you can turn on the external circulation mode. The system will automatically introduce fresh air from outside into the vehicle to improve the air quality inside.

Auto circulation: When selecting "Auto circulation", it automatically switches between internal and external circulation modes according to the air quality inside and outside the car to ensure the air quality inside the car.

VIII. Auto mode

Click the "AUTO" icon to turn on/off the automatic mode. In automatic mode, the system will automatically adjust A/C, air volume, air outlet mode, air circulation, etc., to quickly reach and maintain the set temperature inside the vehicle. After the function is turned on, if you manually adjust A/C, air volume, air outlet mode, etc., you will exit to manual mode.

IX. Windshield defrosting and defogging

Click the "Front Defrost" icon through the A/C control interface to turn on the defrosting and defogging functions of the windshield. This can reduce moisture, fog and frost on the surface of the windshield, improve the front vision, and improve driving safety. Click the icon again to turn off the function.

X. Rear window defrosting and defogging and exterior review mirror heating

Click the "Rear Defrost" icon through the A/C control interface to turn on the defrosting and defogging functions of the rear window and the exterior rearview mirror. This can reduce moisture, fog and frost on the surface of the rear window and the exterior rearview mirror, improve the rear vision, and improve driving safety. Click the icon again to turn off the function.

XI. Air purification

The A/C activated carbon filter element has the function of purifying the air. The vehicle displays the current PM2.5 air quality in the vehicle through the A/C control interface. The air quality level value displays different colors according to the air quality level.

XII. Front-row swing mode

Set the swing mode of electric air outlet on the side of the driver and front passenger cabs through the A/C control interface. There are four modes: manual mode, direct blow, indirect blow and auto sweep. The default blowing angle is fixed. Double click an air outlet to close or open it. There are left and right air outlets on the driver's side. After changing the swing mode, the left/right sides change at the same time.

6 Operation

XIII. A/C air outlet position

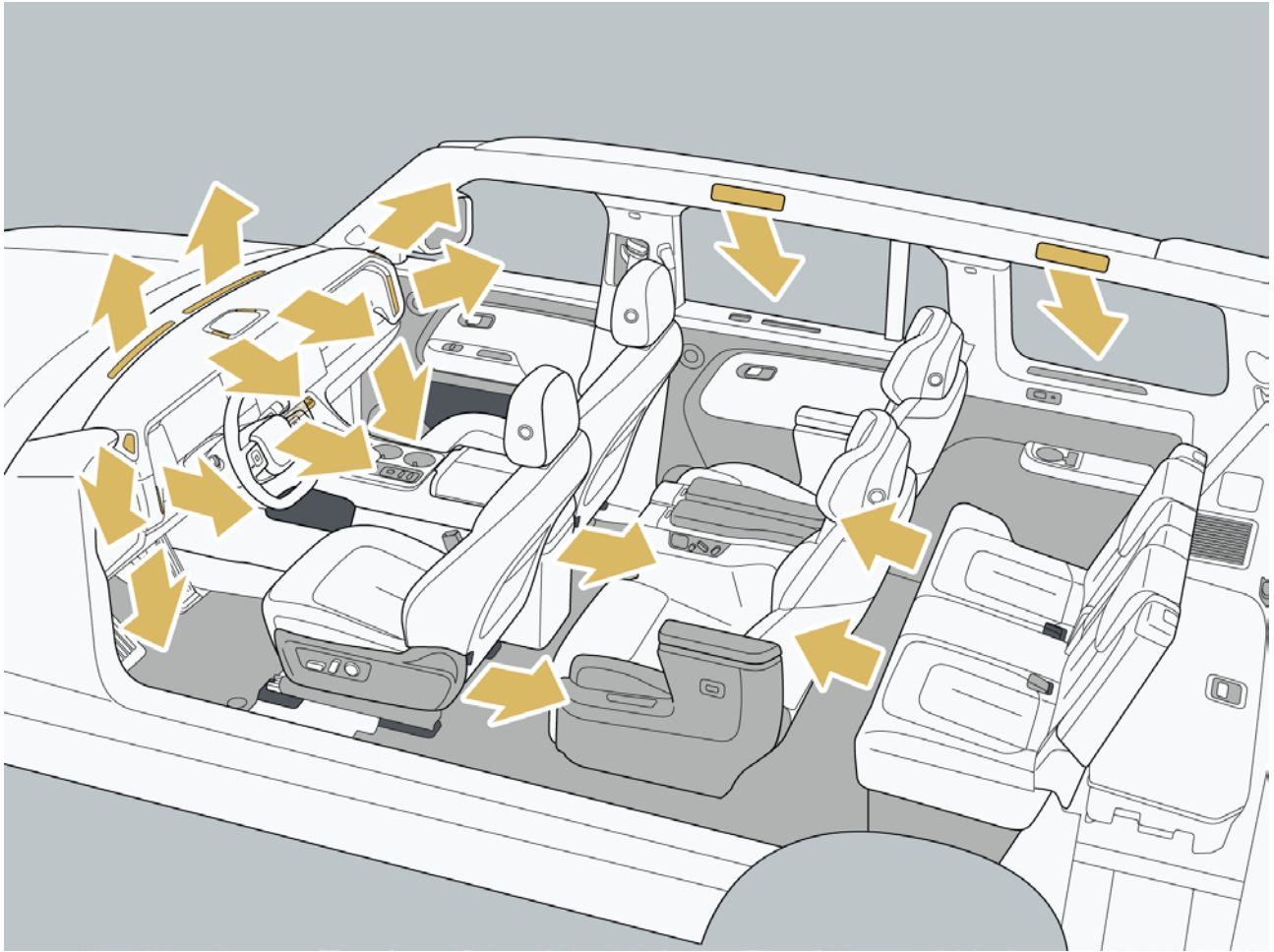

Warning

- While resting in the car for a long period of time, avoid difficulty breathing or suffocation caused by closed windows or poor ventilation.
- Do not place any items on the dashboard. Avoid blocking the air outlet to affect the glass defogging.
- Do not touch the rearview mirror during heating to avoid burns.

Caution

- Check the A/C system in a regular way to keep the A/C system in optimal working condition.
- When using the internal circulation, the recommended use time is within 30 min.
- Clean the A/C condenser with a low-pressure water gun in a regular way to prevent leaves and insects accumulating on its surface from hindering the airflow, resulting in the reduction of the refrigeration effect.

6.7.2 Rear AC system

I. Control through the front central control screen

Click the A/C icon on the central control screen to open the control A/C Control interface. Click the "Switch to Rear Row" icon to switch to the rear A/C control interface.



II. Rear A/C switch

Click the "Switch" icon through the A/C control interface to turn on the rear A/C. Click again to turn off the rear A/C. When turning off the rear A/C, the rear A/C can be turned by the following operations:

- Turn on rear A/C auto mode.
- Set rear A/C air speed.
- Set rear A/C blowing mode.

II. Temperature setting

Set the temperature of the rear A/C by sliding up/down through the A/C control interface. Each slide can increase or decrease the temperature by 0.5°C. Fast slide can quickly adjust the temperature. The set temperature is adjustable within LO (16°C) ~ Hi (28°C).

IV. Air speed adjustment

Click the "Air Speed" icon on the A/C control interface to set the air speed gear. For each click, the air speed gear will change to a gear. Slide left/right to quickly adjust the air speed.

V. Rear-row blowing mode

Click one of the "Blowing mode" icons to select three blowing modes: blowing face, blowing foot and blowing face + foot.

6 Operation

XI. Auto mode

Click the "AUTO" icon through the A/C control interface to turn on/Off the automatic mode. In automatic mode, the system will automatically adjust the air volume, air outlet mode, etc., to quickly reach and maintain the set temperature of the rear seats.

XII. Rear A/C lock

This function is off by default. The A/C lock function can be turned on by clicking the "A/C Lock" icon on the control interface of the A/C system control interface. When the function is turned on, the rear row A/C control panel is unavailable.

VIII. Rear-row intelligent A/C

This function is off by default. Click "Rear Intelligent A/C" through the A/C interface to turn on or off the rear intelligent A/C function.

After the rear intelligent A/C is turned on, if the vehicle detects that the rear passengers get off for more than 3 min, the rear A/C will automatically turn off. After the rear passengers get on for exceeding 10 s, the rear A/C will automatically turn on. The A/C state is the state when it was last turned off.

Hint

- When the remote A/C is turned on, the automatic shutdown function of the rear A/C is not available.

IX. Rear A/C control panel control

S/N	Name	S/N	Name
1	Seat ventilation	5	Rear A/C switch
2	Temperature setting	6	Blowing mode
3	Automatic mode	7	Seat heating
4	Air speed setting		

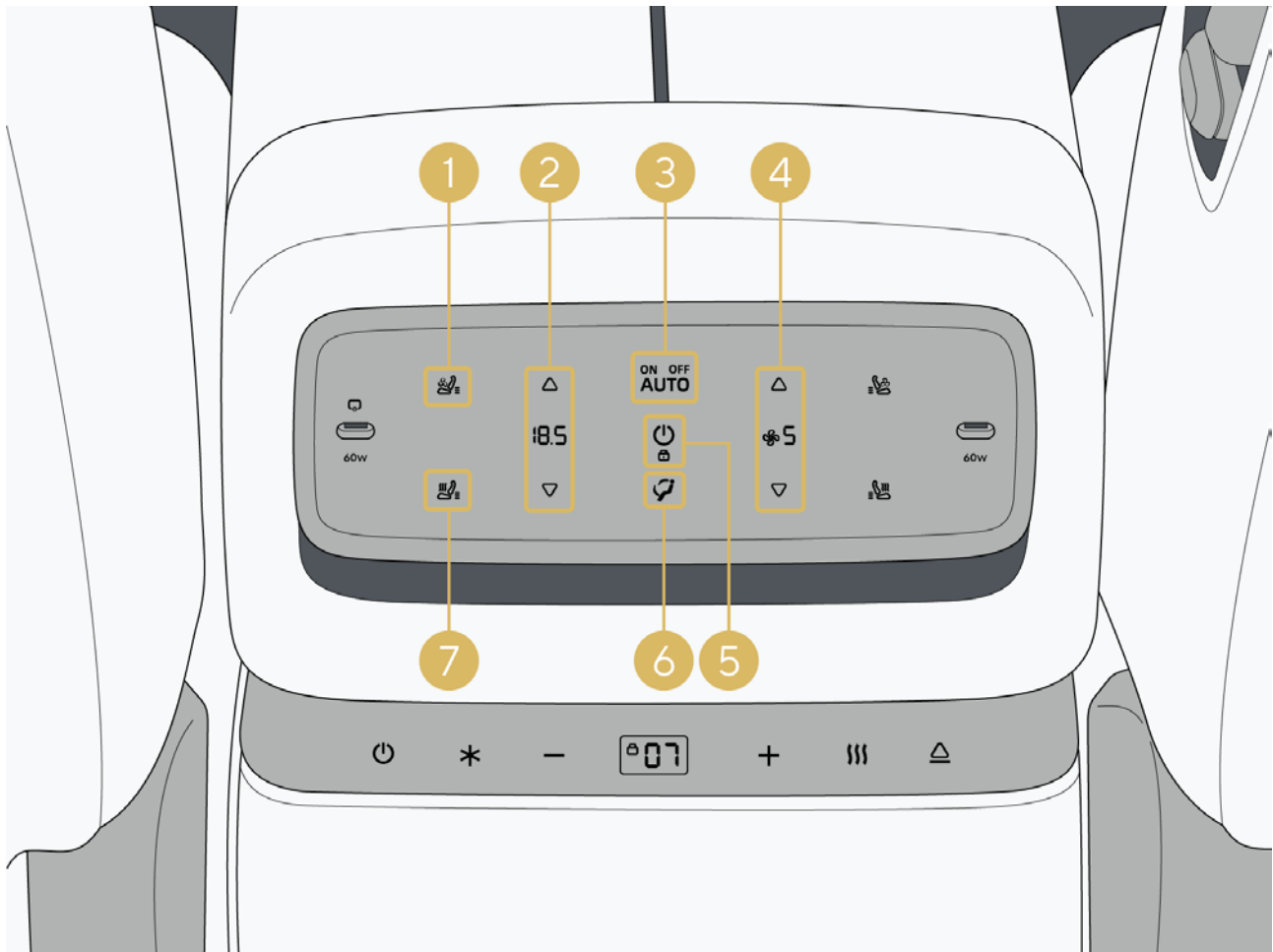

1. Front row seat ventilation

Click the icon to switch the ventilation intensity to level 3, 2, 1 or off.

2. Temperature setting

Short press the temperature adjustment button up/down to set the rear temperature. Each short press can increase or decrease the temperature by 0.5°C. Long press the temperature adjustment button up/down to quickly adjust the temperature.

3. Automatic mode

Click the "AUTO" button to change the rear A/C into the automatic mode. The system will automatically adjust the blowing temperature, blowing mode and air speed.

6 Operation

4. Air speed setting

Short press the air speed adjustment button up/down to set the air speed gear. Each press can change the air speed gear to another position. Long press the air speed adjustment button up/down to quickly adjust the air speed gear.

5. Rear A/C switch

Click the button to turn on/off the rear A/C.

6. Blowing mode

Click the “Blowing Mode” button to select blowing mode: blowing face, blowing foot, or blowing face and foot.

7. Seat heating

Click the icon to switch the heating intensity to level 3, 2, 1 or off.

X. Air outlet position

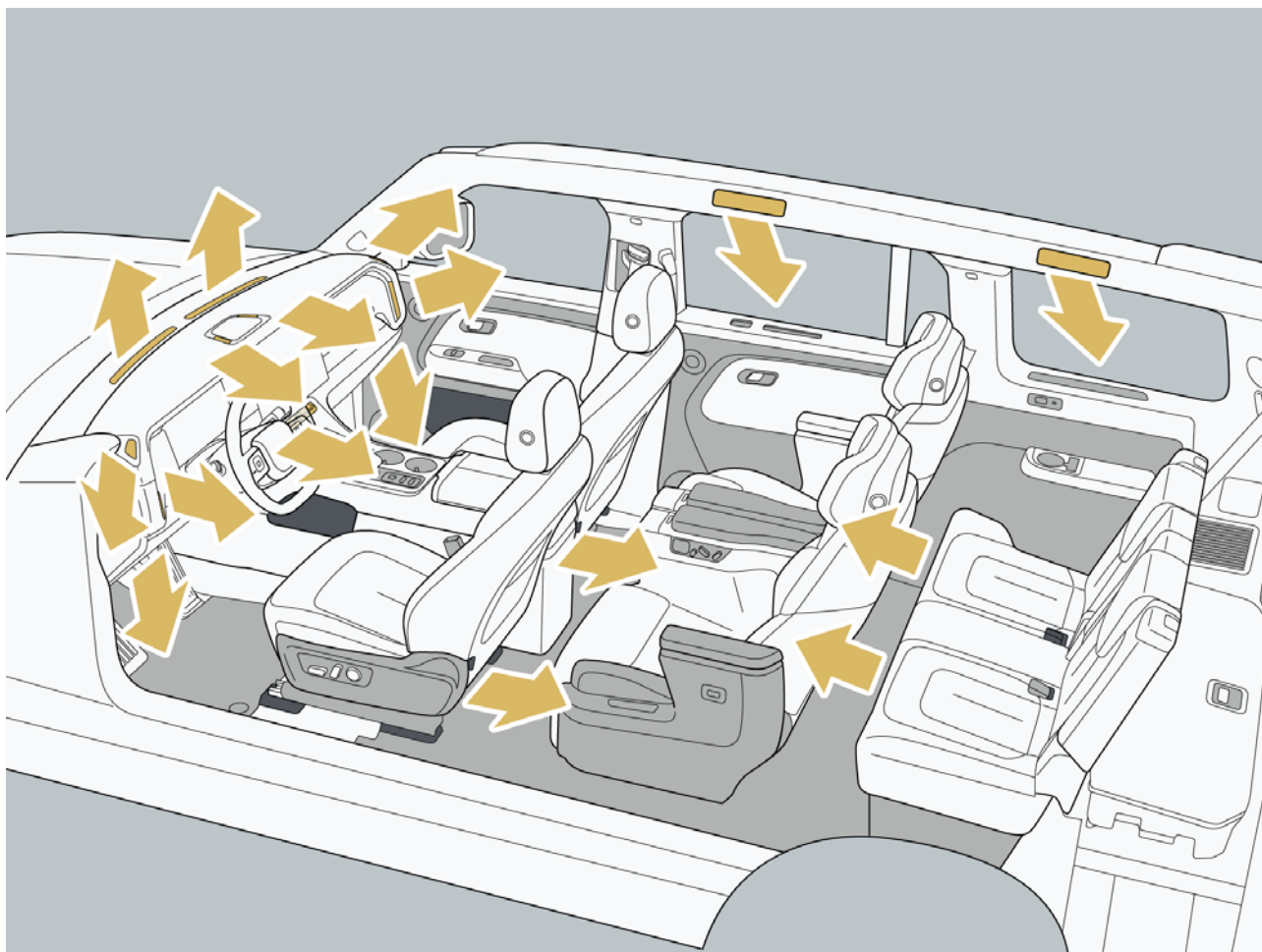

XI. Roof air outlet

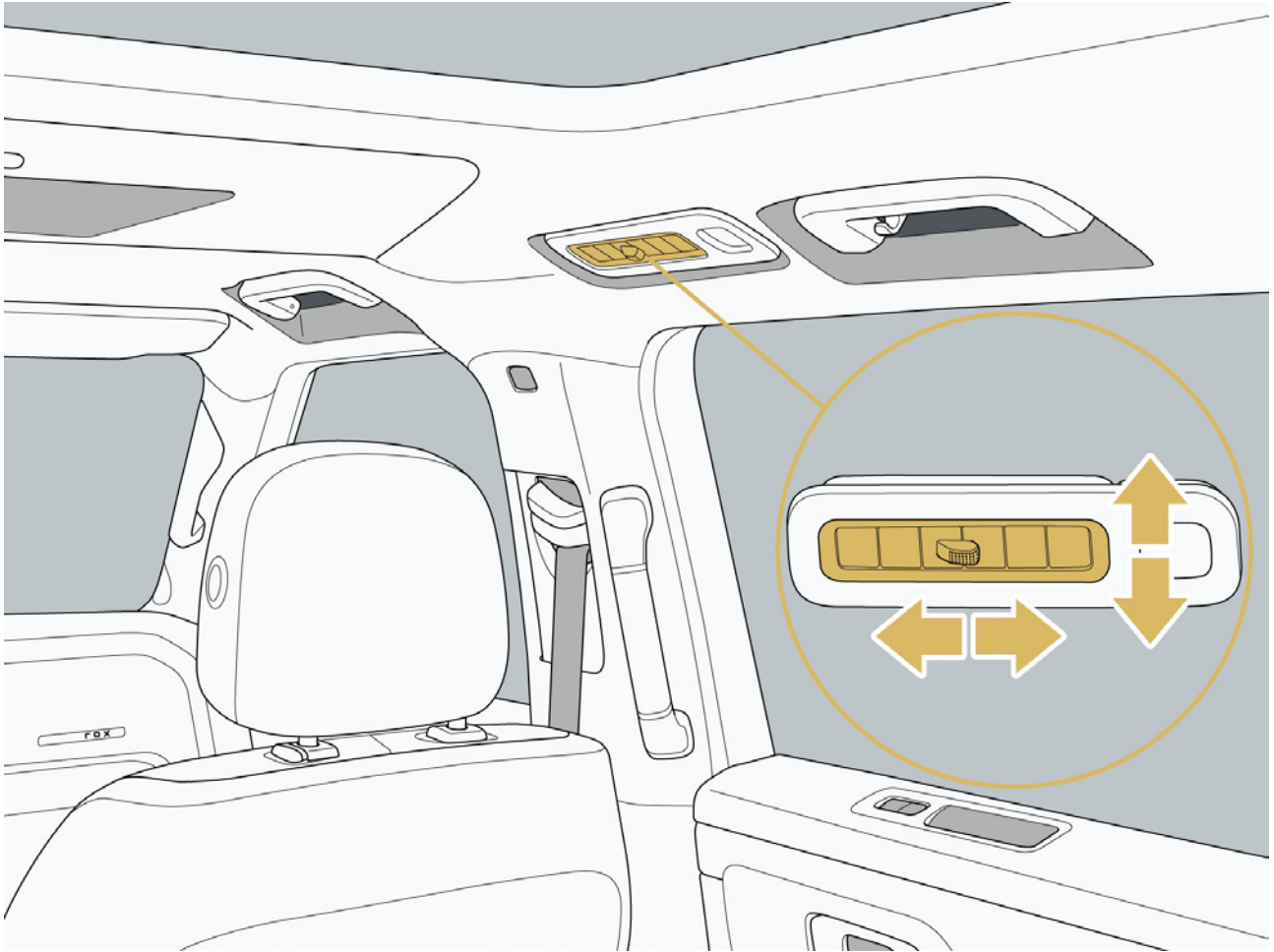

6 Operation

6.7.3 Steering wheel heating/seat heating and ventilation

I. Steering wheel heating

Click the "Steering Wheel Heating" icon on the "A/C Control" interface of the central control screen to turn on the steering wheel heating function. Click again to turn off the steering wheel heating function.

II. Front seat heating/seat ventilation

Click "Seat" icon on the A/C control interface to enter the front-row seat operation interface.

Activation: Click the "Seat Heating" and "Seat Ventilation" icons of the front-row seat on the A/C system control interface to select the heating and ventilation gears for the driver's seat and the front passenger's seat respectively.

Deactivation: With the seat heated or ventilated, click the "Seat Heating" or "Seat Ventilation" icons until it is turned off. The seat heating function consists of three gears: 3, 2 and 1. Gear 3 has the highest temperature, and gear 1 has the lowest temperature.

The seat ventilation function consists of three gears: 3, 2 and 1. Gear 3 has the highest air force, and gear 1 has the lowest air force.

III. Second-row seat heating/seat ventilation (common seat)

- Turn on/off the seat heating/seat ventilation function through the rear A/C control panel.

Activation: Press the "Seat Heating/Seat Ventilation" button on the rear A/C control interface to select the seat heating/ventilation gear for the left/ right seat in the second-row respectively.

Deactivation: With the seat heated or ventilated, click the "Seat Heating/Seat Ventilation" button until it is turned off. The seat heating function consists of three gears: 3, 2 and 1. Gear 3 has the highest temperature, and gear 1 has the lowest temperature.

The seat ventilation function consists of three gears: 3, 2 and 1. Gear 3 has the highest air force, and gear 1 has the lowest air force.

- Click "Seat → Switch to Second Row" through the A/C control interface to enter the rear seat operation interface or turn on/off seat heating through the rear A/C control panel.

Activation: Click the "Seat Heating" and "Seat Ventilation" icons of the second-row seat on the A/C system control interface to select the heating and ventilation gears for the left/right seats of the second row respectively.

Deactivation: With the seat heated or ventilated, click the "Seat Heating" or "Seat Ventilation" icons until it is turned off. The seat heating function consists of three gears: 3, 2 and 1. Gear 3 has the highest temperature, and gear 1 has the lowest temperature.

The seat ventilation function consists of three gears: 3, 2 and 1. Gear 3 has the highest air force, and gear 1 has the lowest air force.

Hint

- Seat ventilation and seat heating functions cannot be turned on at the same time.

IV. Second-row seat heating/seat ventilation (aviation seat)

Click "Seat → Switch to Second Row" through the A/C control interface to enter the rear seat operation interface or turn on/off seat heating through the rear A/C control panel.

Activation: Click the "Seat Heating" and "Seat Ventilation" icons of the second-row seat on the A/C system control interface to select the heating and ventilation gears for the left/right seats of the second row respectively.

Deactivation: With the seat heated or ventilated, click the "Seat Heating" or "Seat Ventilation" icons until it is turned off. The seat heating function consists of three gears: 3, 2 and 1. Gear 3 has the highest temperature, and gear 1 has the lowest temperature.

The seat ventilation function consists of three gears: 3, 2 and 1. Gear 3 has the highest air force, and gear 1 has the lowest air force.

Hint

- Seat ventilation and seat heating functions cannot be turned on at the same time.

V. Second-row seat heating/seat ventilation (aviation seat)

Activation: Short press the "Seat Heating/Ventilation" button on the control panel to cycle through the seat heating/ventilation gear.

Deactivation: With the seat heated or ventilated, press the "Seat Heating" or "Seat Ventilation" buttons until it is turned off.

Hint

- Seat ventilation and seat heating functions cannot be turned on at the same time.

6 Operation

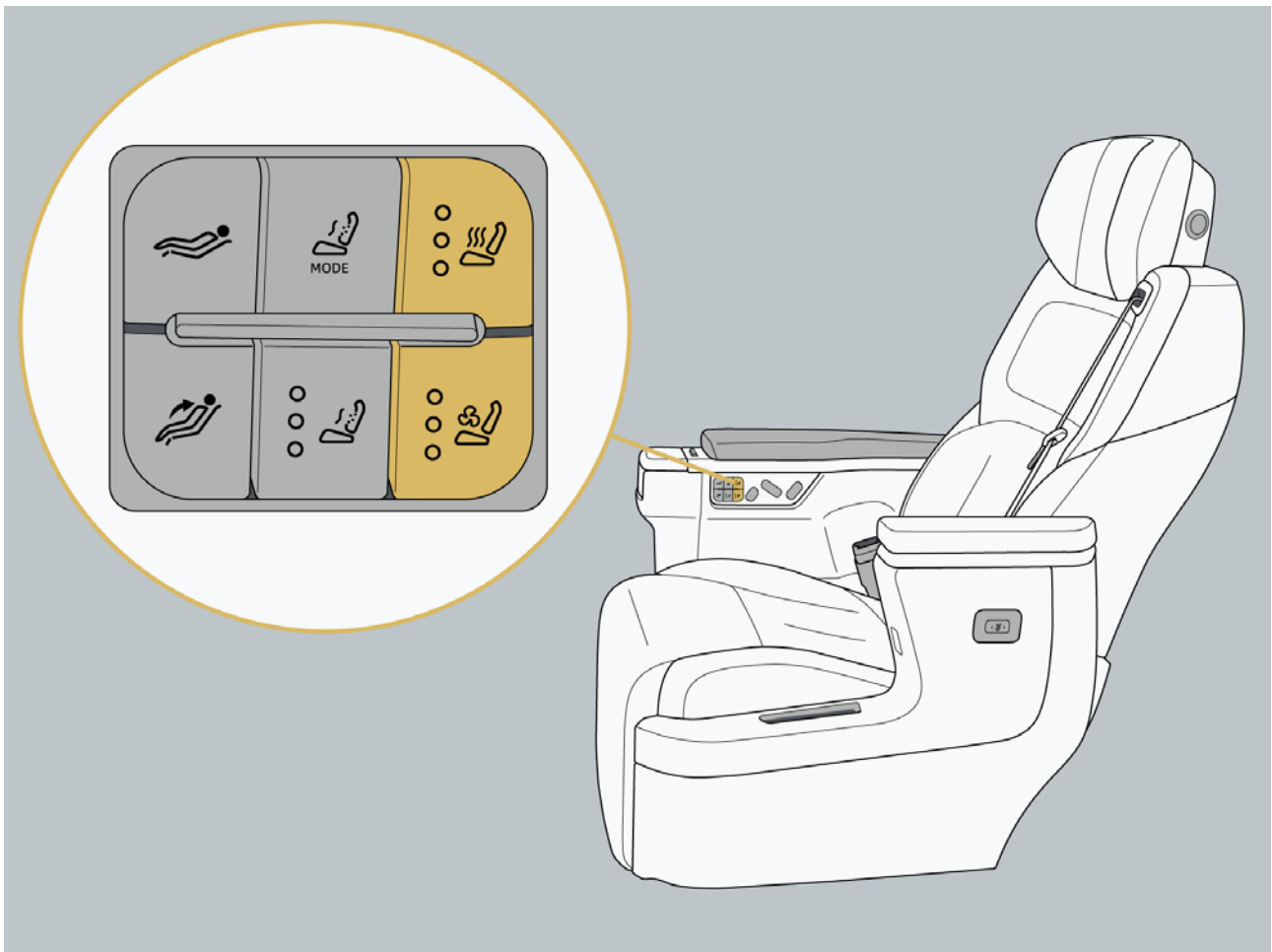

VI. Seat ventilation/heating memory

When the seat ventilation/heating function is on, it automatically remembers the seat ventilation/heating position before the vehicle is powered off and restores the seat ventilation/heating function before the vehicle is powered on next time.

Warning

- Children, the elderly, the sick, the disabled and people with limited pain perception should be particularly careful when using heating function.
- When using seat heating, do not cover the seat with blanket or cushion, etc., to avoid damage or burns.
- Do not place sharp objects on the seat to avoid damaging the heating/ventilation device.
- Turn off the heater when there is no occupant to avoid damage.

6.8 Vehicle interior illumination light

6.8.1 Interior reading lamp control

I. Control of central control screen

The reading lamp switch on the central control screen has three gears: always on, always off, and auto. Click "Vehicle Settings → Vehicle → Light → Reading lamp" through the central control screen to control the reading lamp:

- Fully open: Turn on all reading lamps in the car.
- Fully closed: Turn off all reading lamps in the car.
- Auto: Turn on the reading lamp auto mode.

II. Control of interior reading lamp switch

You can separately control the on and off of each reading lamp with the interior reading lamp switch. Touch the reading lamp switch once to turn on the reading lamp on. Touch it again to turn it off.

Hint

- The operation method of the reading lamps in the second row and the third row is the same as that of in the front row.

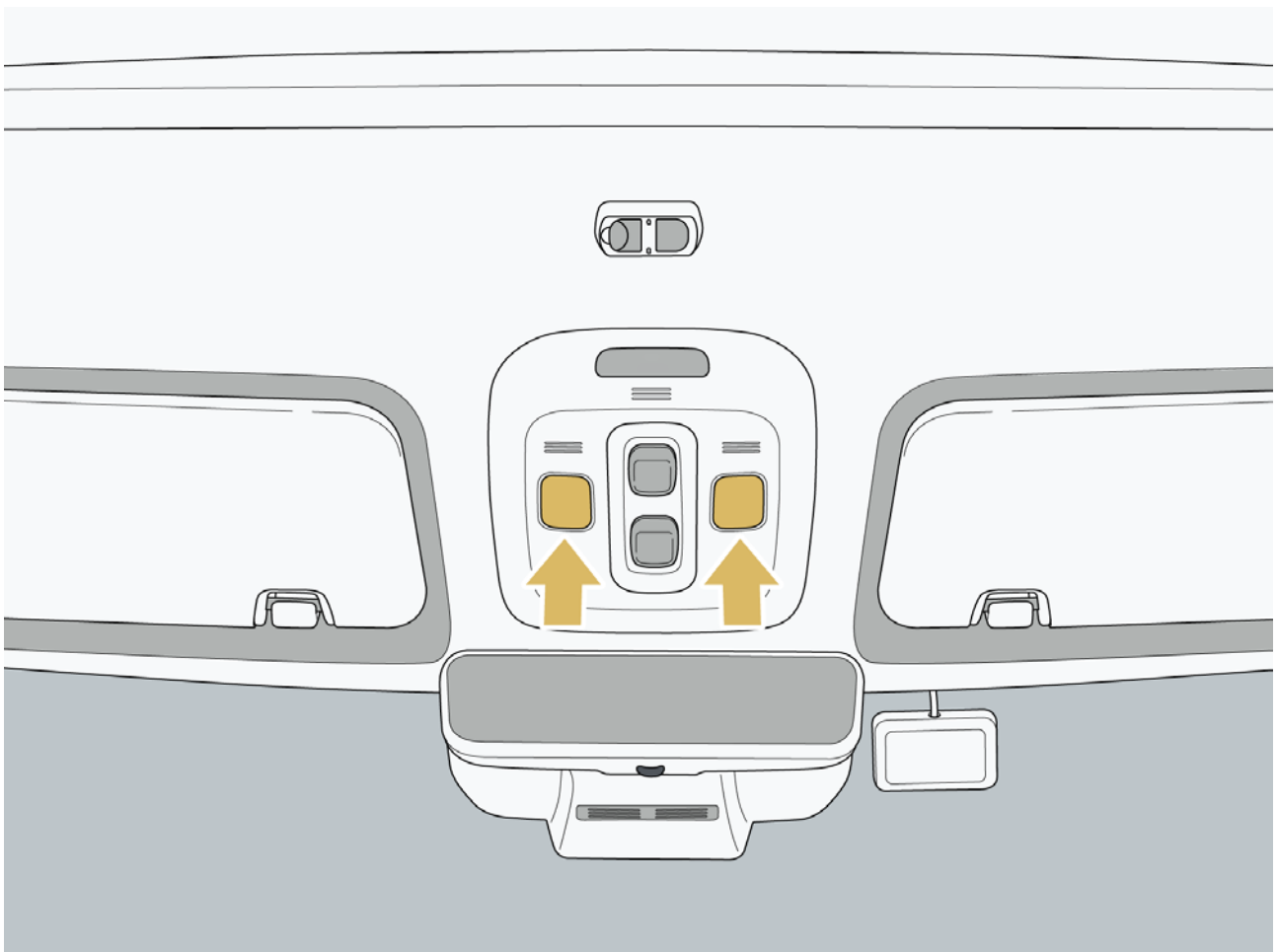

6 Operation

III. Reading lamp auto mode

After the reading lamp auto mode is turned on, when opening any door, the reading lamp will automatically turn on. After the reading lamp automatically illuminates, it will automatically go out if:

- The vehicle is locked from outside.
- The vehicle power supply is switched from "OFF" mode to "ON" or "READY" mode.
- All doors are closed.

IV. Automatically light up when in P gear

When the reading light setting in P gear is turned on, shift into P gear and the reading light will light up.

Hint

- After locking the car, the reading lamp will go out after a delay of 30 s.

6.8.2 Vanity lamp

When opening the vanity mirror cover, the vanity lamp will illuminate; When closing the vanity mirror cover, the vanity lamp will go out.

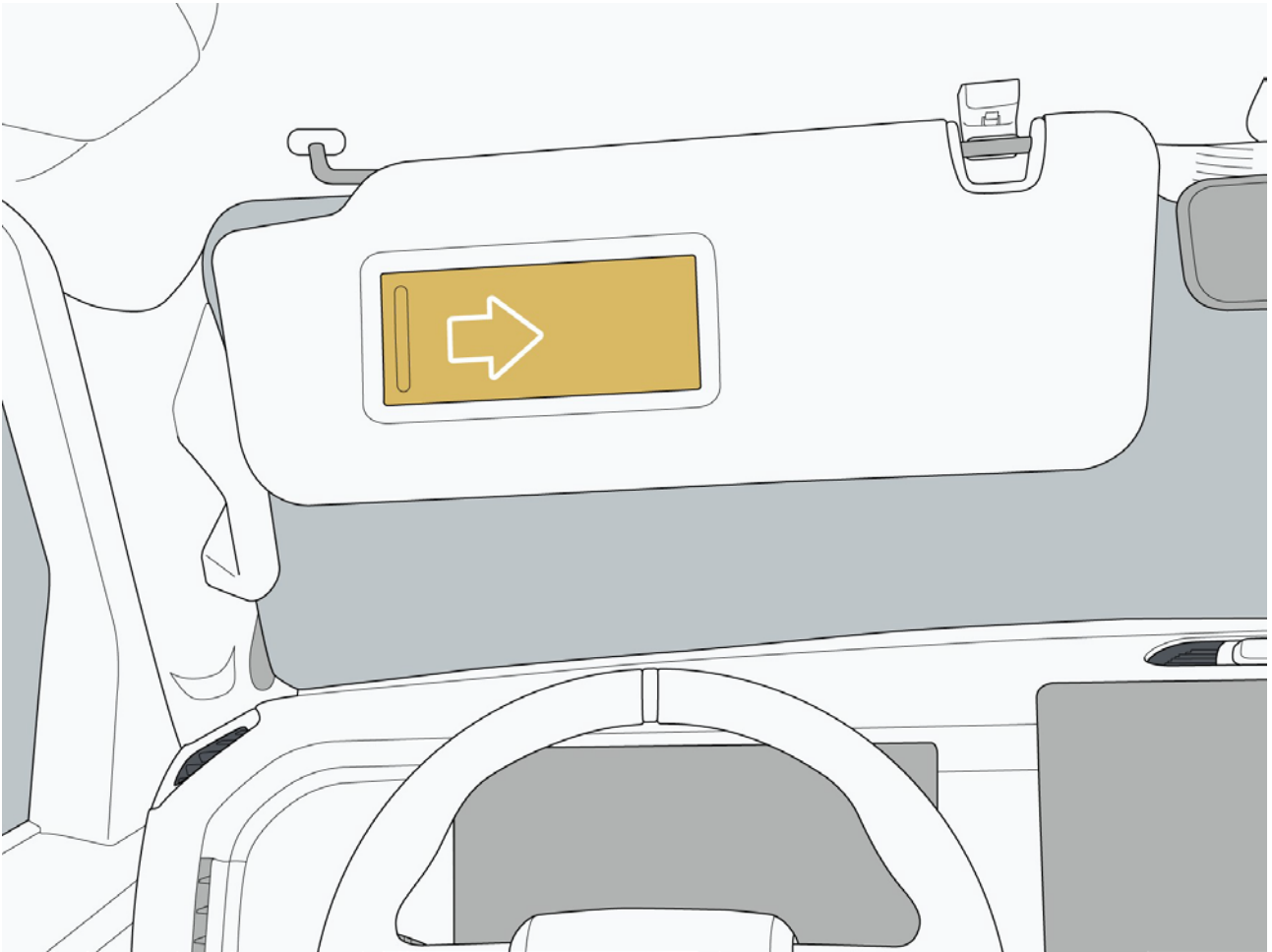

6 Operation

6.8.3 Ambient light

The vehicle provides ambient lamp in the car. You can set the ambient lamp effect according to your personal preferences. This will bring a pleasant driving experience for you. Click "Vehicle Settings → Vehicle → Ambient Light" through the central control screen to enter the ambient lamp control interface.

I. Activate/deactivate

Click the option under the ambient lamp to set the ambient lamp:

- Always on: Turn on the ambient lamp to keep it always on.
- Breathing: Turn on the ambient lamp to keep it in a breathe state.
- Theme: Choose different ambient lighting themes according to your preferences.

II. Brightness of ambient lamp

Slide the slider on the right side of "Ambient Light Brightness" to adjust the brightness.

Hint

- When the ambient lamp mode is "Breathe", the brightness cannot be adjusted.

III. Ambient lamp mode

Click the option under the ambient lamp mode to adjust the ambient lamp mode. There are three modes for the ambient lamp mode: always on, breathe and theme. The default is always on.

IV. Ambient lamp color

After the ambient lamp is turned on, click the corresponding color icon to set the ambient lamp color.

6.8.4 Welcome light illumination

When you carry the remote key or Bluetooth key close to/away from the vehicle, the door handle welcome lamp will automatically lamp on/off. To enable/disable the welcome function, click the "Vehicle Settings → Vehicle → Light → Approach Welcome" through the central control screen for setting.

6.9 Storage device

6.9.1 Glove box

I. Open the glove box

Open: Pull the glove box switch to open the glove box.

Close: Push the glove box directly to the closed position until you hear a click sound.

II. Glove box lamp

When the glove box is opened, the glove box lamp automatically illuminates.

Warning

- To avoid damaging the glove box, do not use too much force when pulling the glove box.
- During driving, the glove box must be closed to avoid the items in the glove box flying out and injuring the occupants when the vehicle is braking urgently or in an accident.

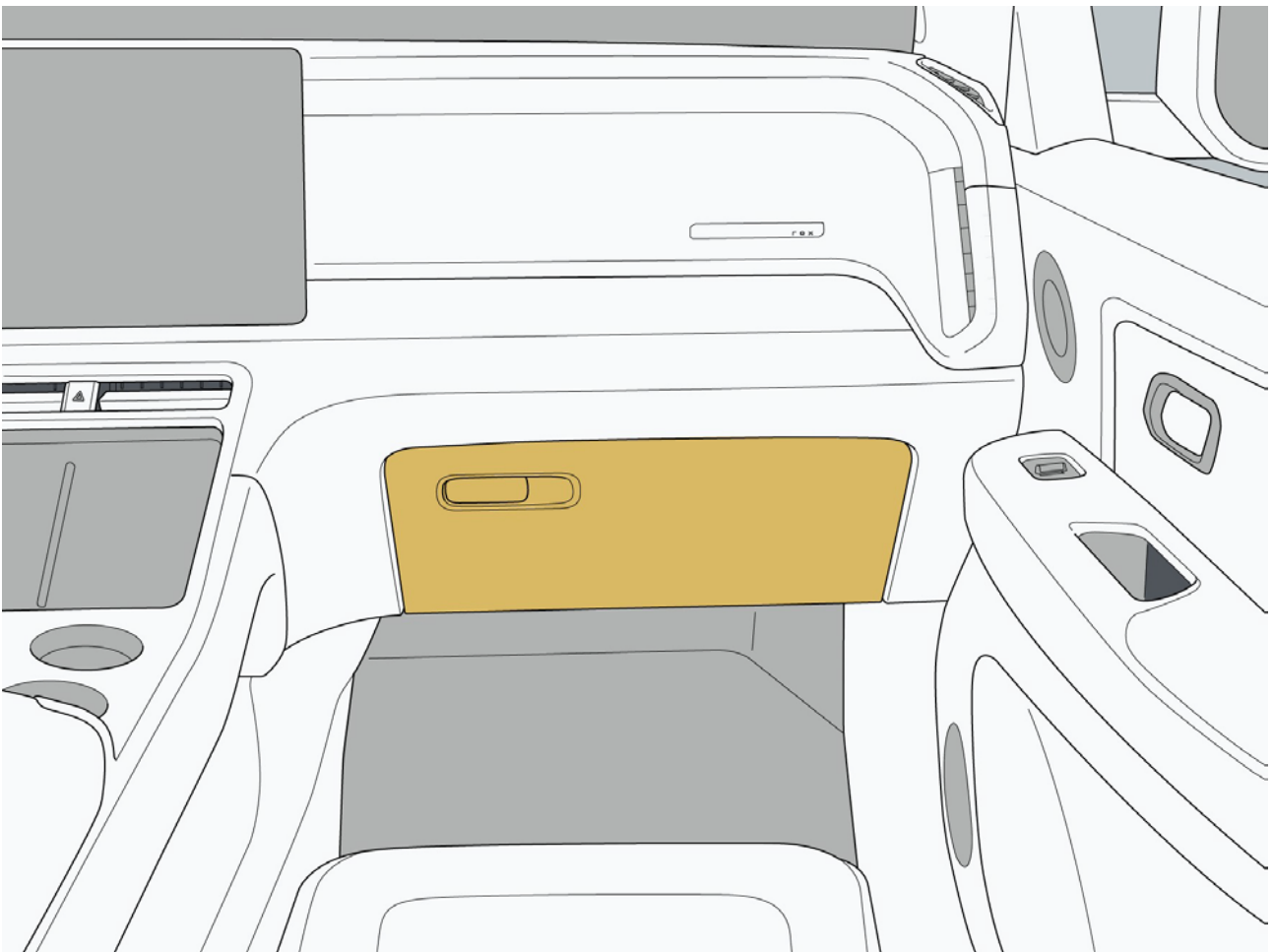

6 Operation

6.9.2 Storage box

I. Armrest box

The armrest box not only effectively relieves the fatigue of the driver's arms, but also has an internal space for you to store items.

- Open: Press the button on the armrest box to open it.
- Close: Press the armrest box covers on both sides until they are fully closed.

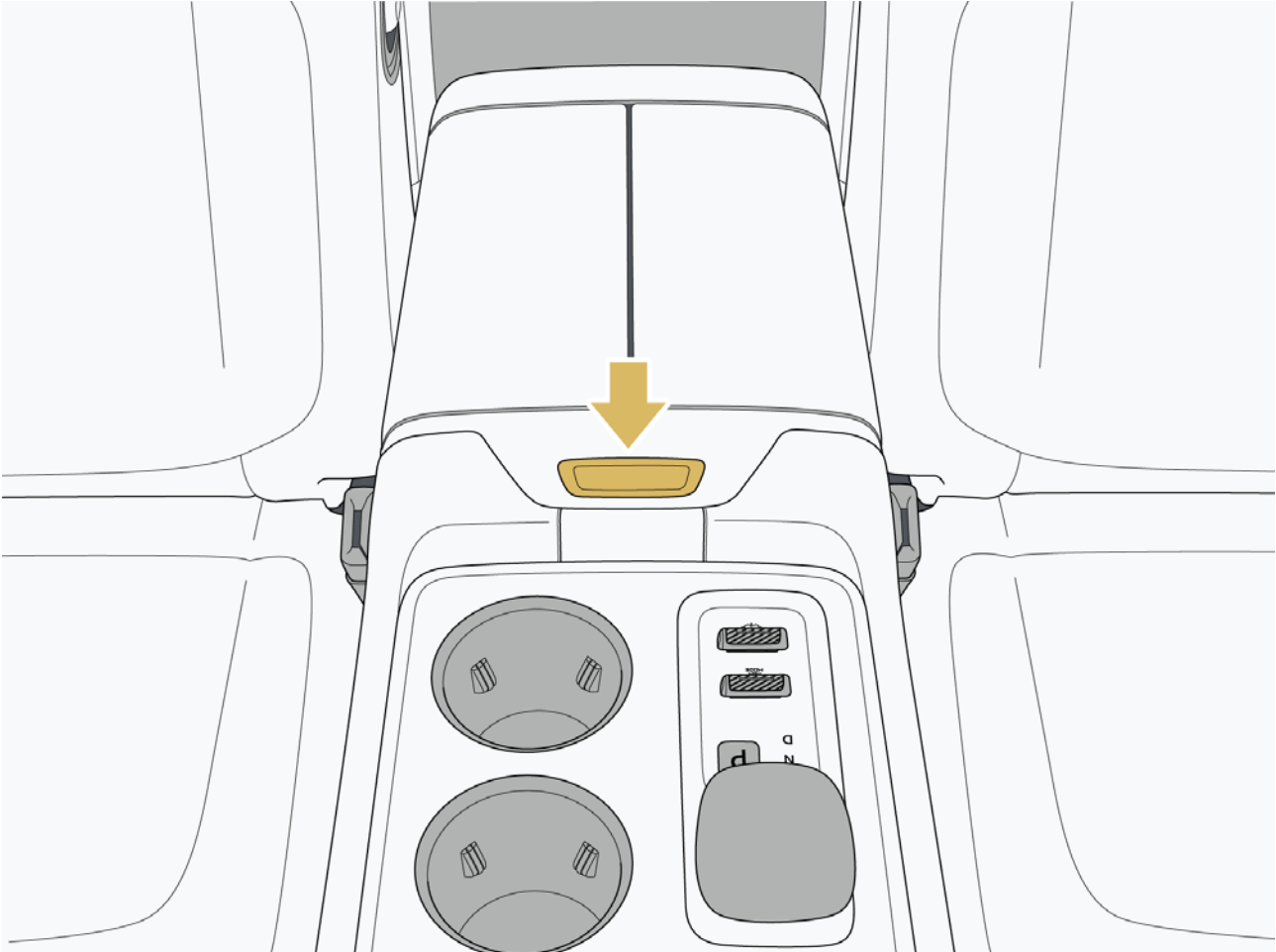

II. Central console lower storage box

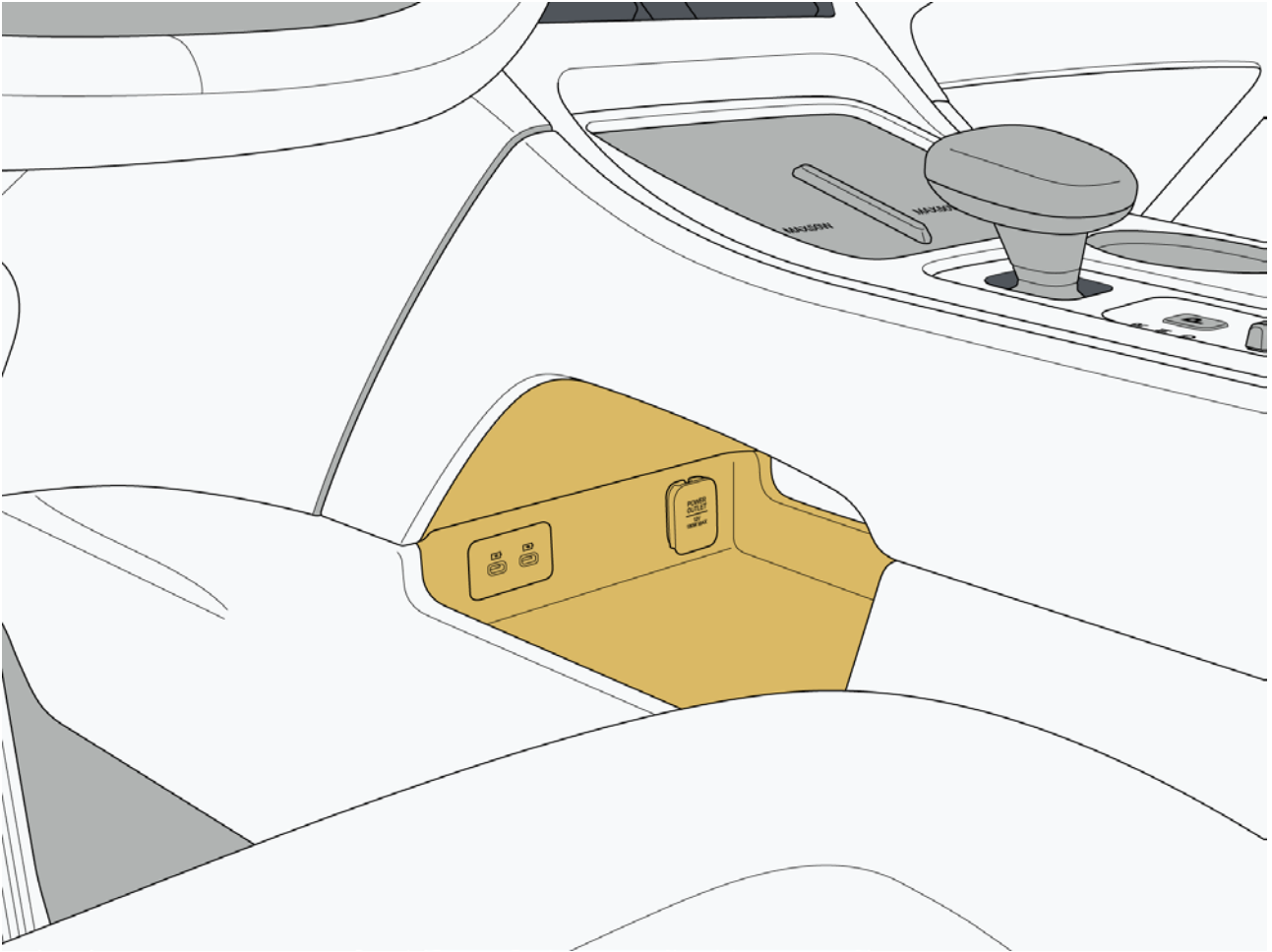

6 Operation

III. Door storage box

There are door panel storage boxes on all four doors and the tailgate of the vehicle, where you can store your items.

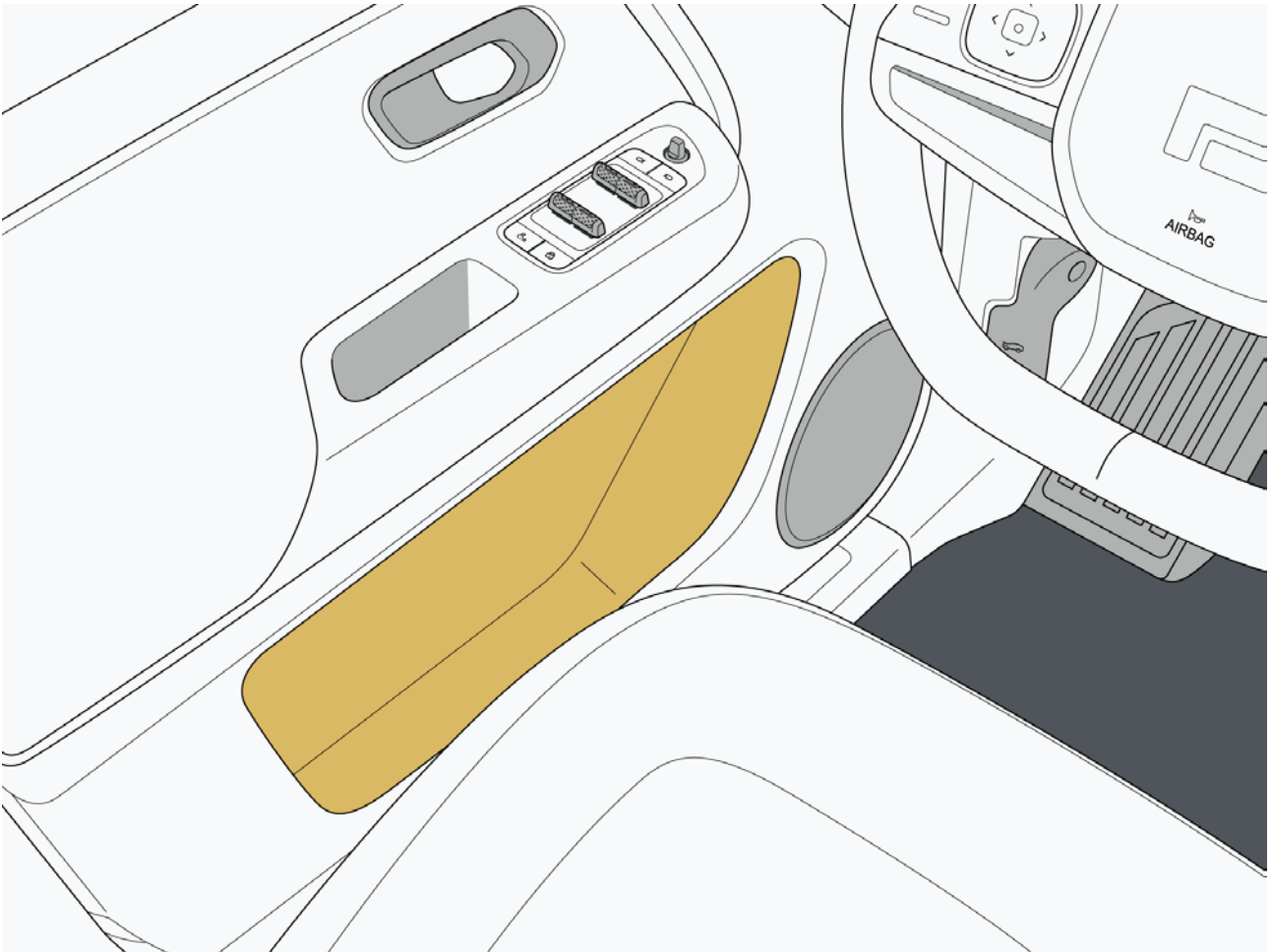

IV. Glasses box

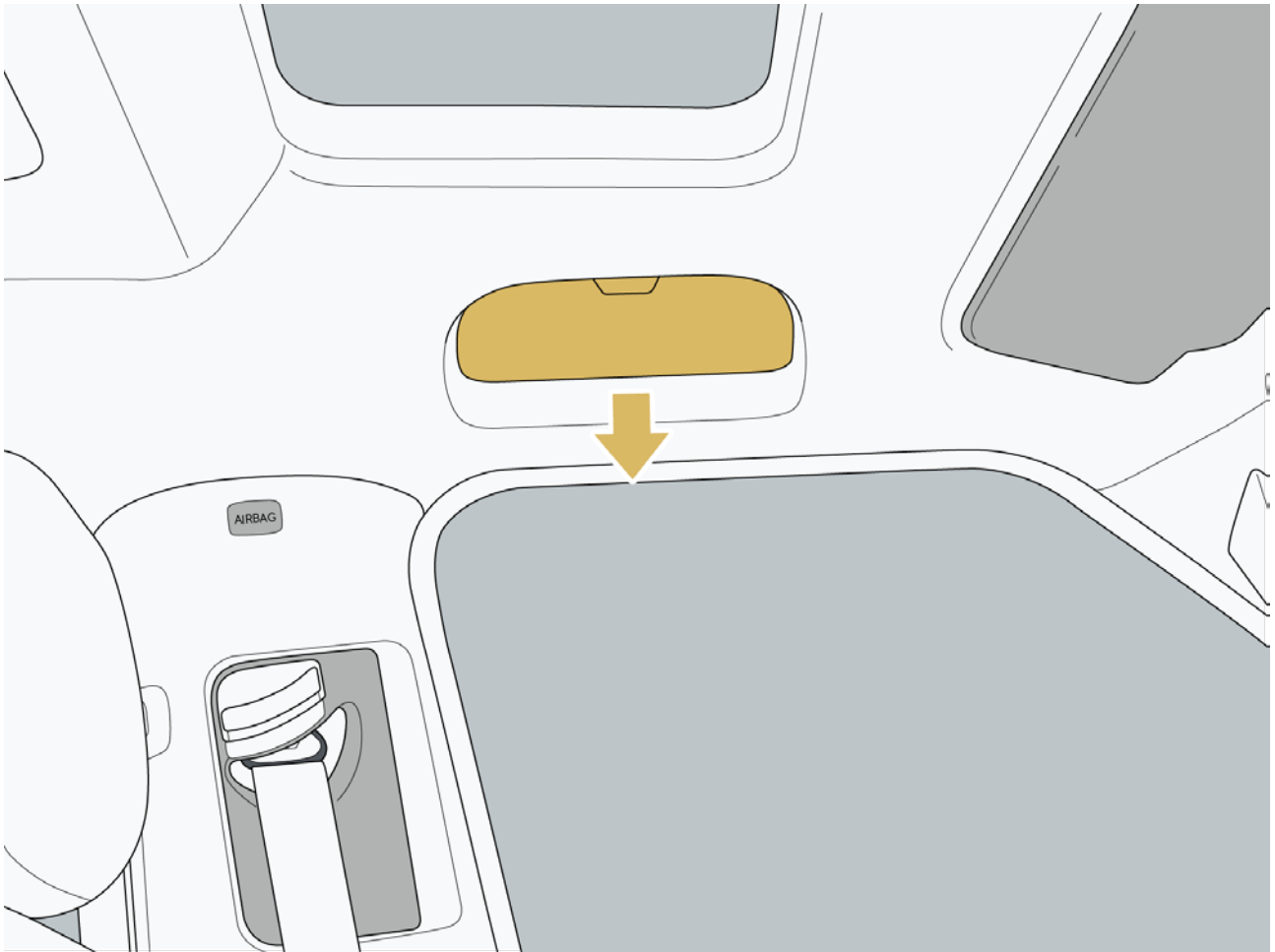

6 Operation

V. Second row seat storage pot

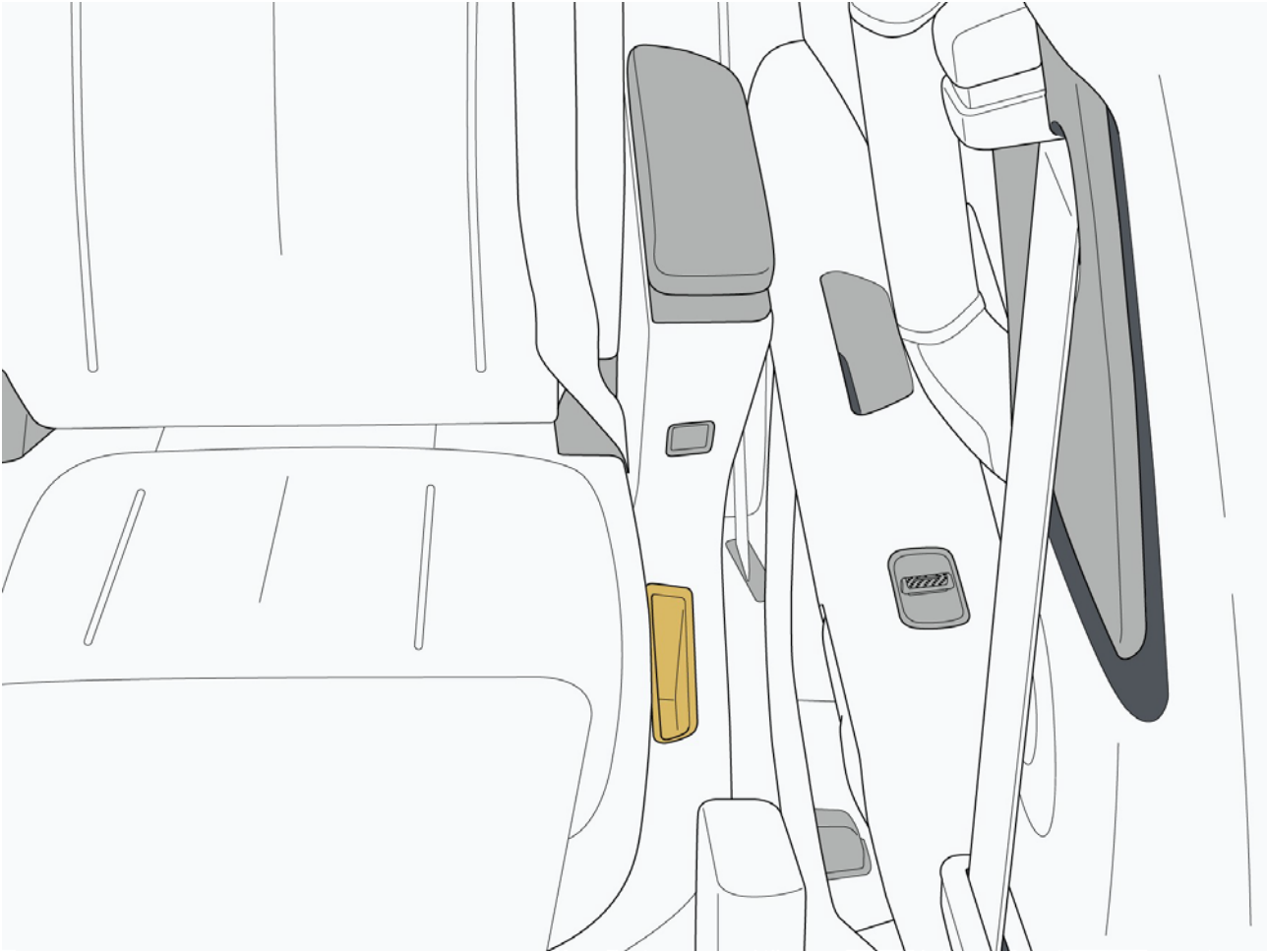

6.9.3 Cup holder

I. Front-row cup holder

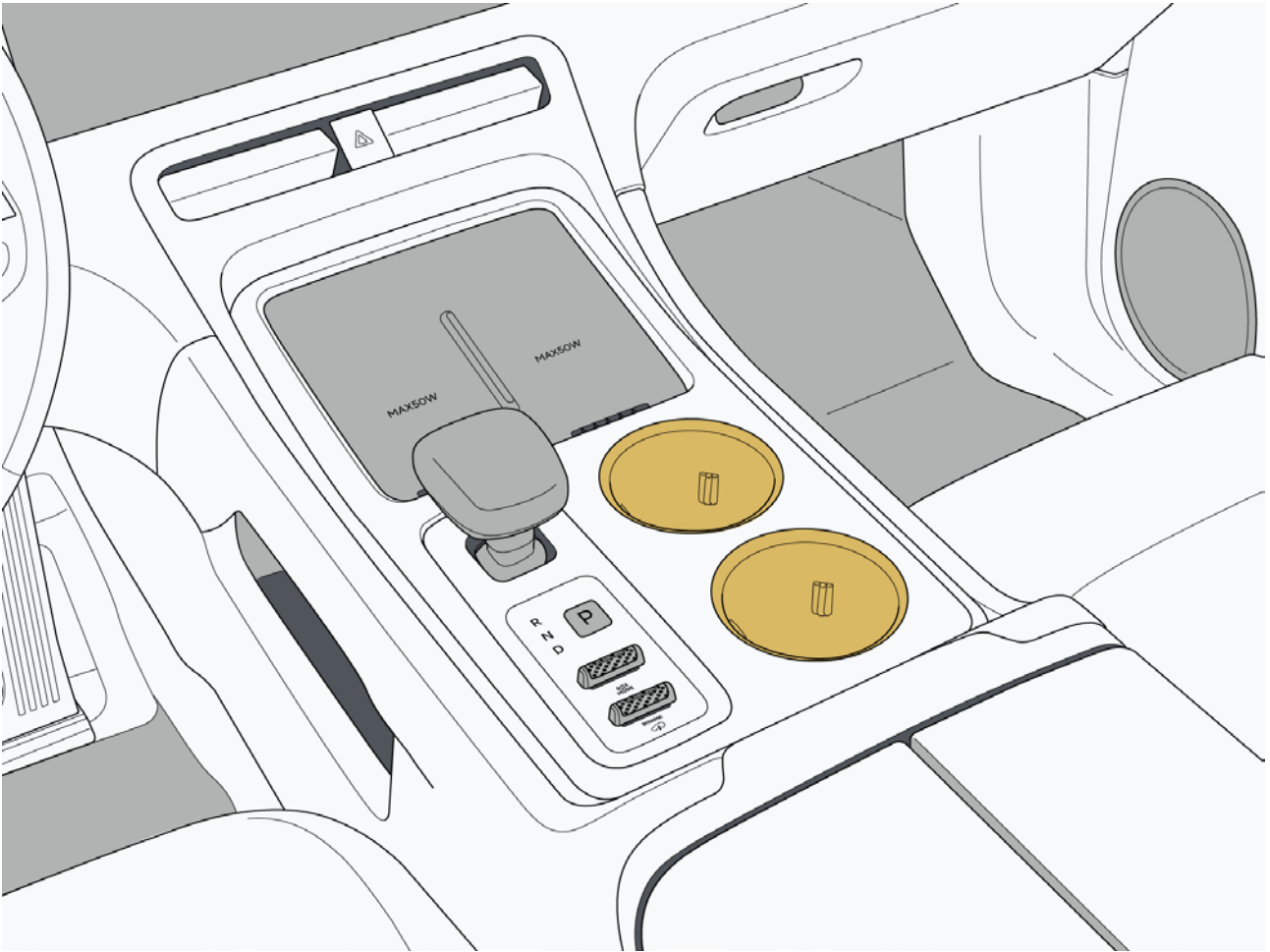

6 Operation

II. Second row cup holder (aviation seat)

Press the button on the front of the seat armrest to open the cup holder support.

Hint

- The second-row cup holder is close to the seat adjustment panel. When placing the cup, tighten the cup lid to prevent liquid from splashing on the seat adjustment panel and causing damage to the electronics inside the control panel.



III. Third-row cup holder

Warning

- Do not place anything other than a cup in the cup holder to avoid dropping items or damaging the cup holder.
- When placing a cup with hot water in the holder, tighten the lid to avoid burns.

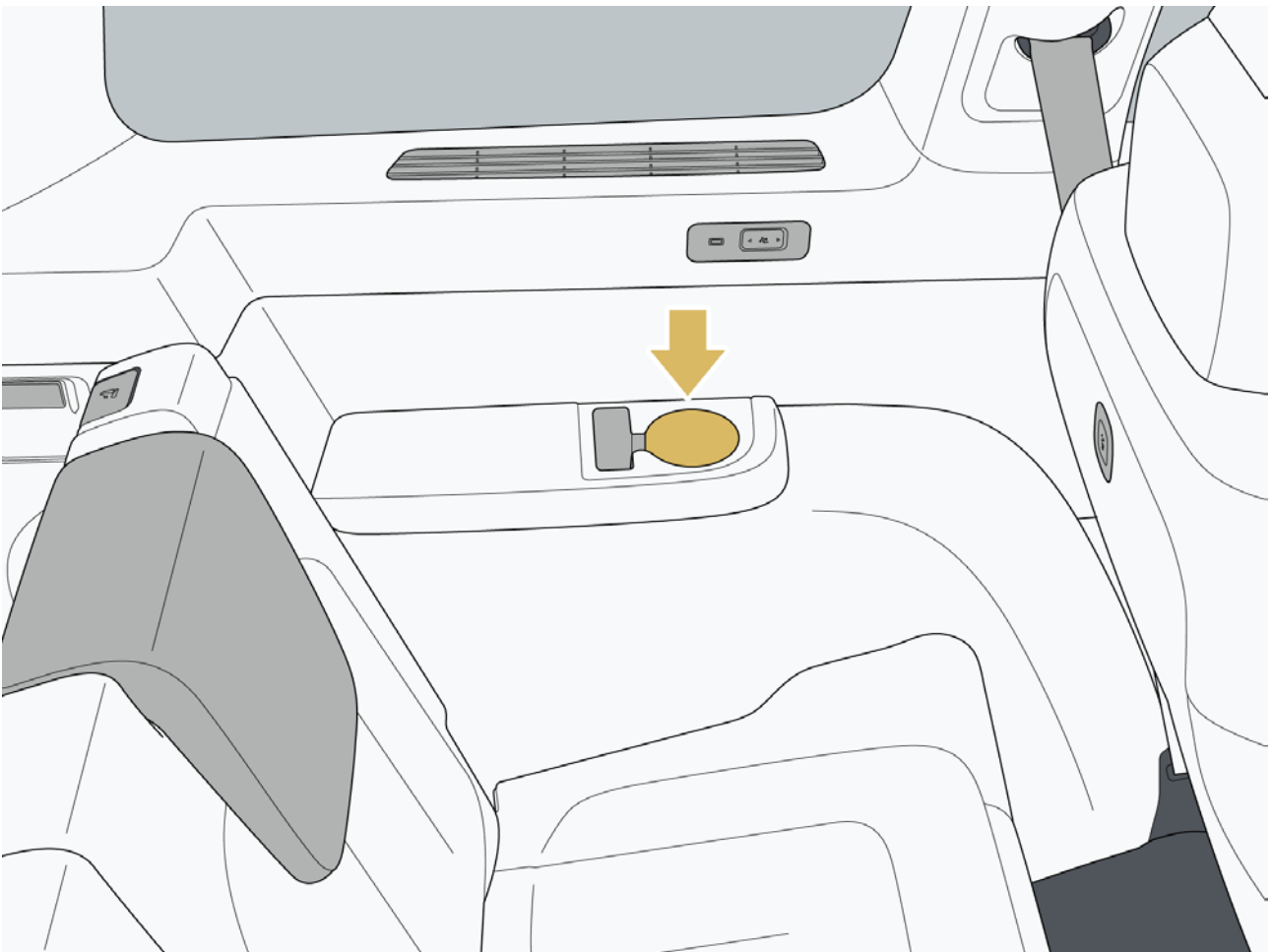

6 Operation

6.9.4 Seat map pocket

Open the map pocket behind the first-row seat, you can put you book, ipad and other objects in it.

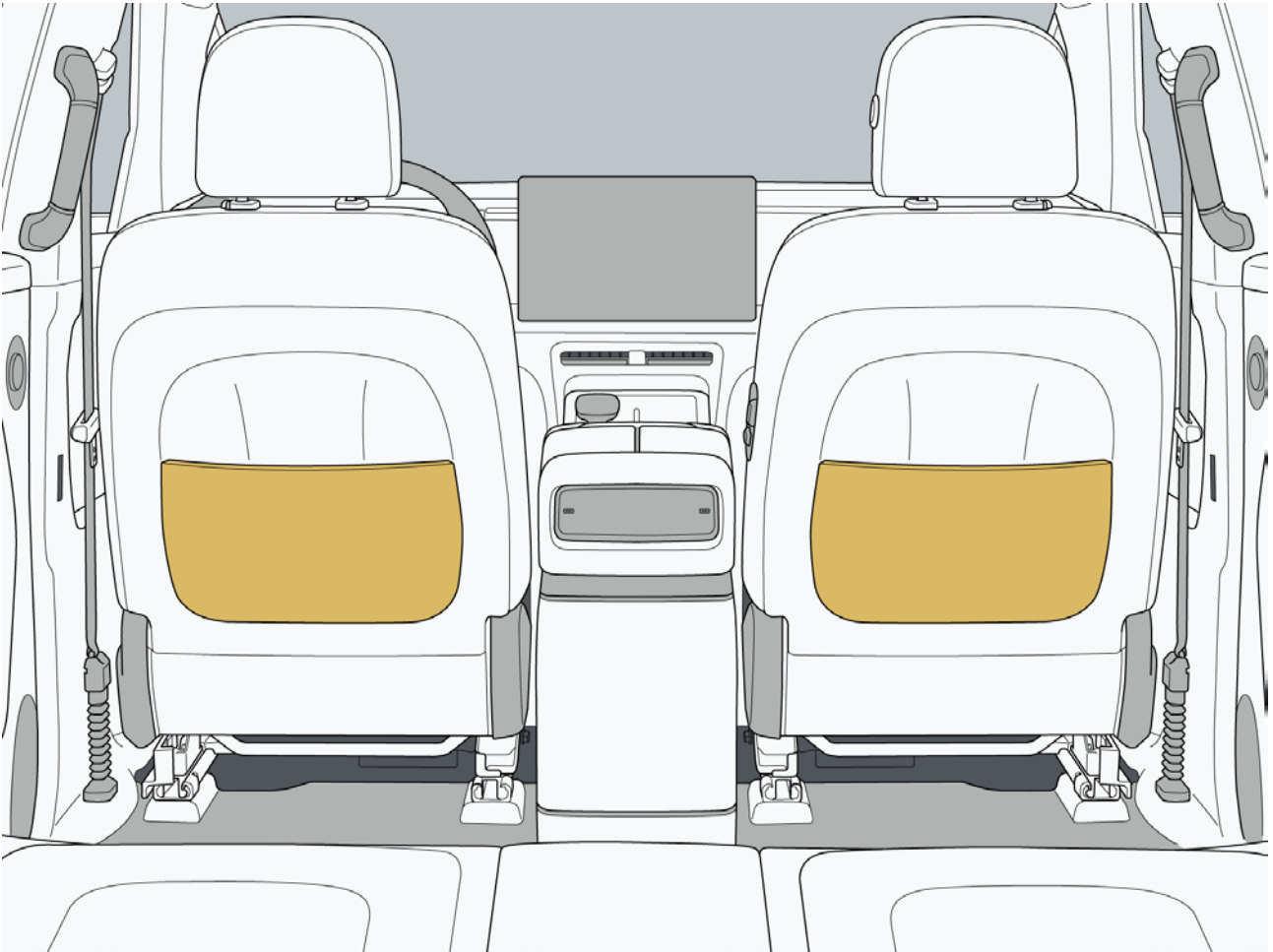

6.9.5 Trunk equipment

I. Trunk mat

Press the back of the luggage pad handle to lift the luggage pad upwards through the handle.

Caution

- When placing items in the trunk, the items should be fixed. Unfixed items may cause serious injuries to drivers and passengers in case of a collision or emergency braking.

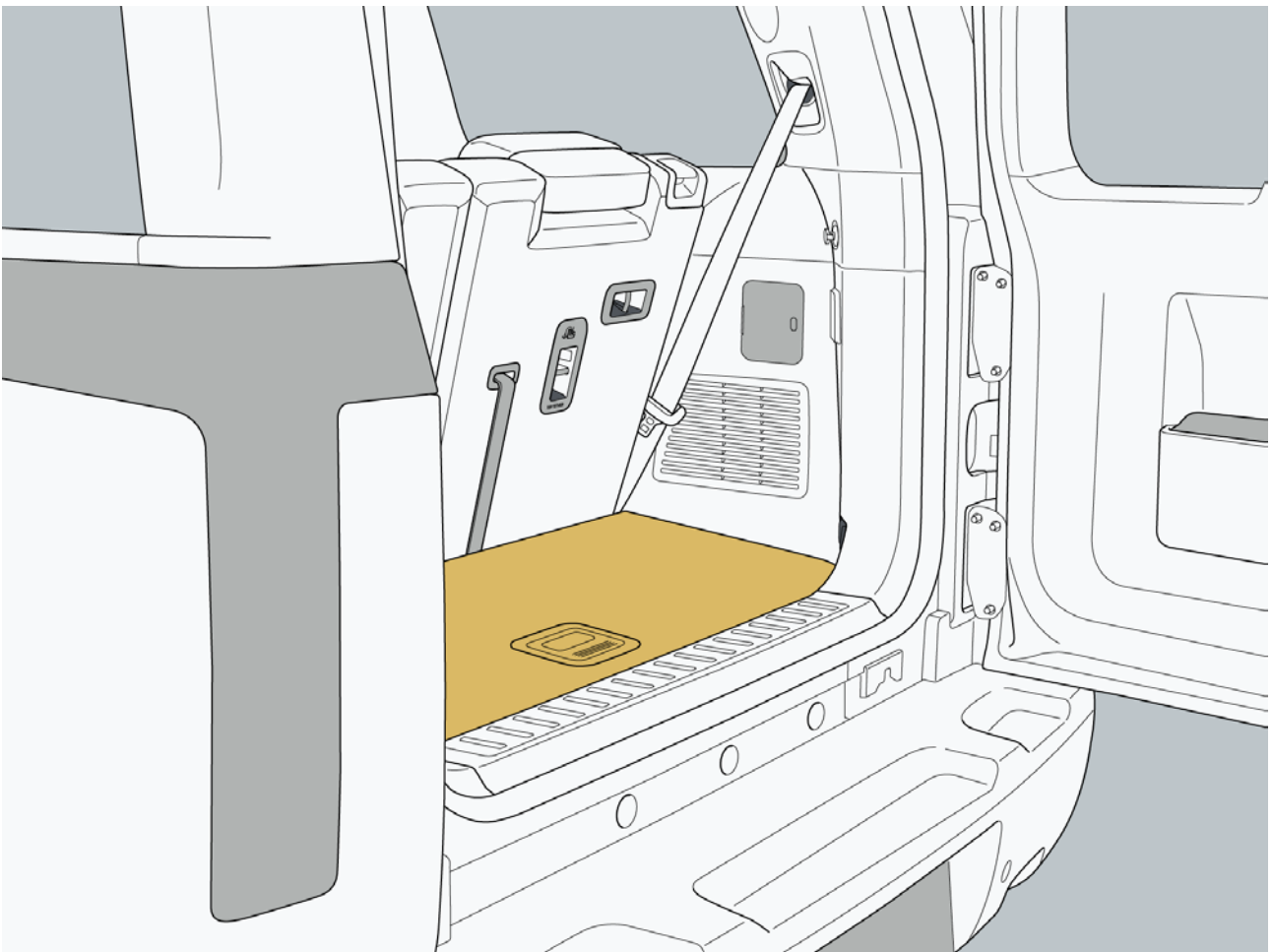

6 Operation

II. Luggage floor hook and hanger

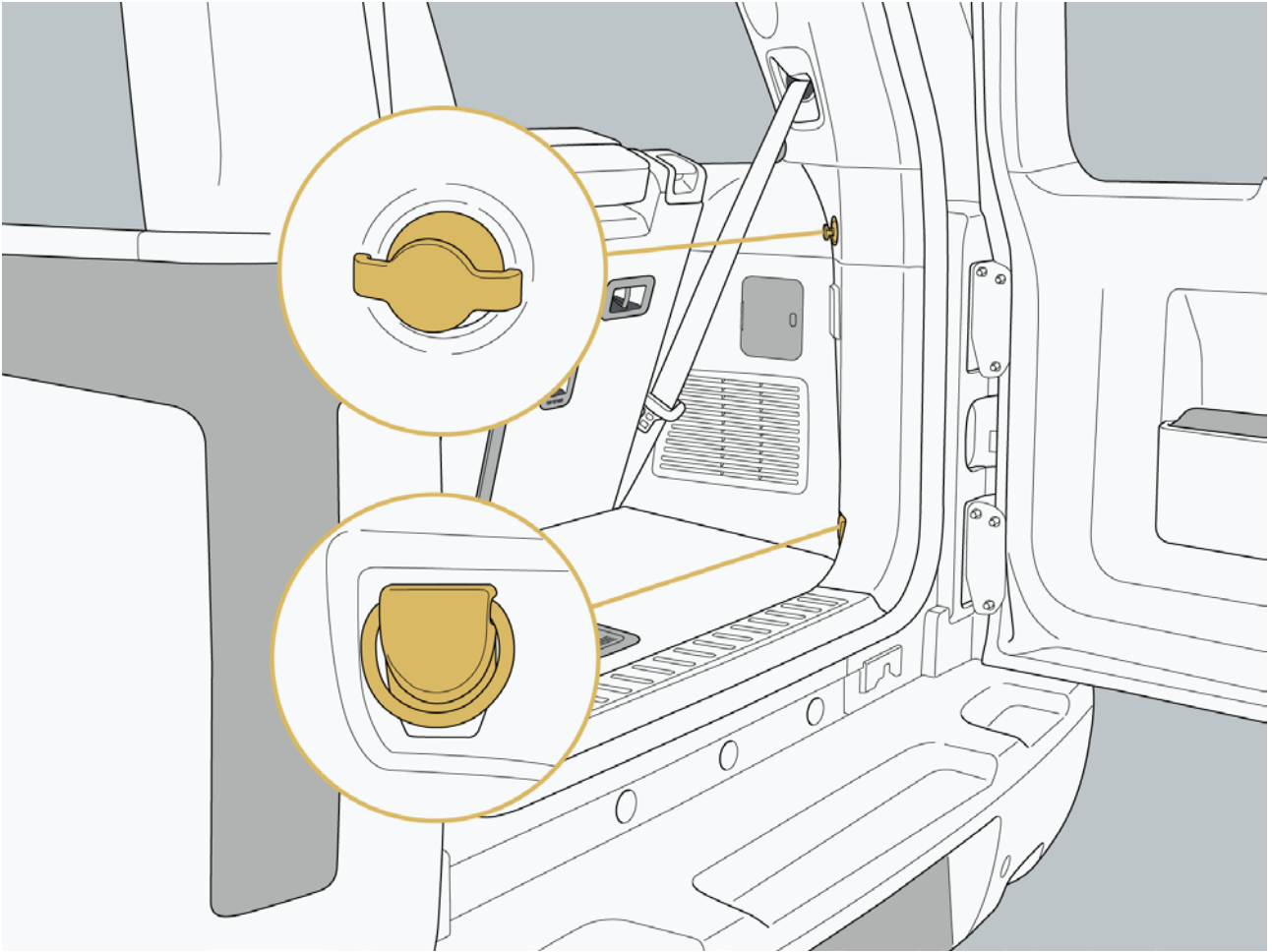

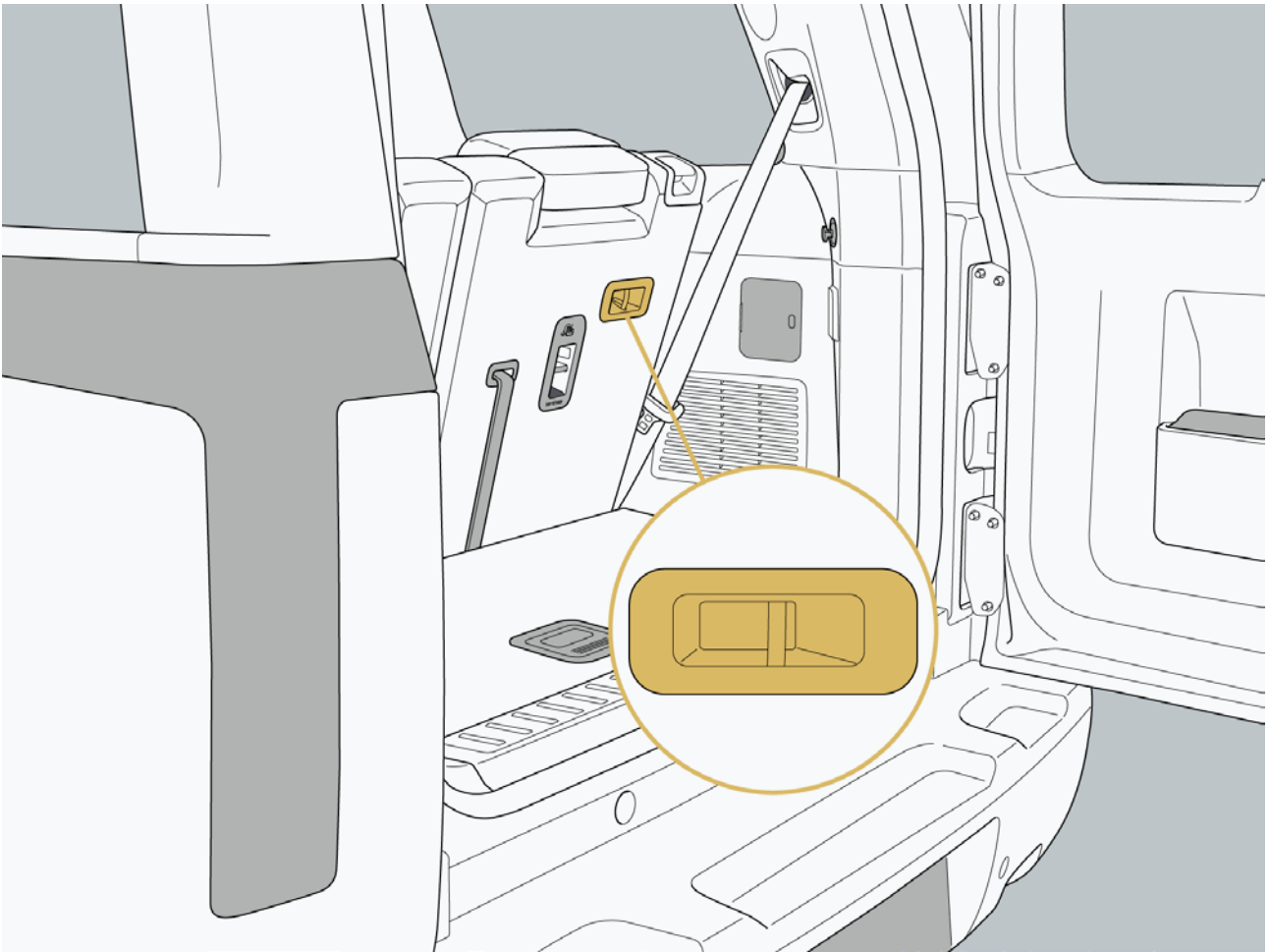

6 Operation

III. Luggage hanger

There is a luggage hanger on each side, and the maximum carrying capacity of the luggage hanger does not exceed 3 kg.

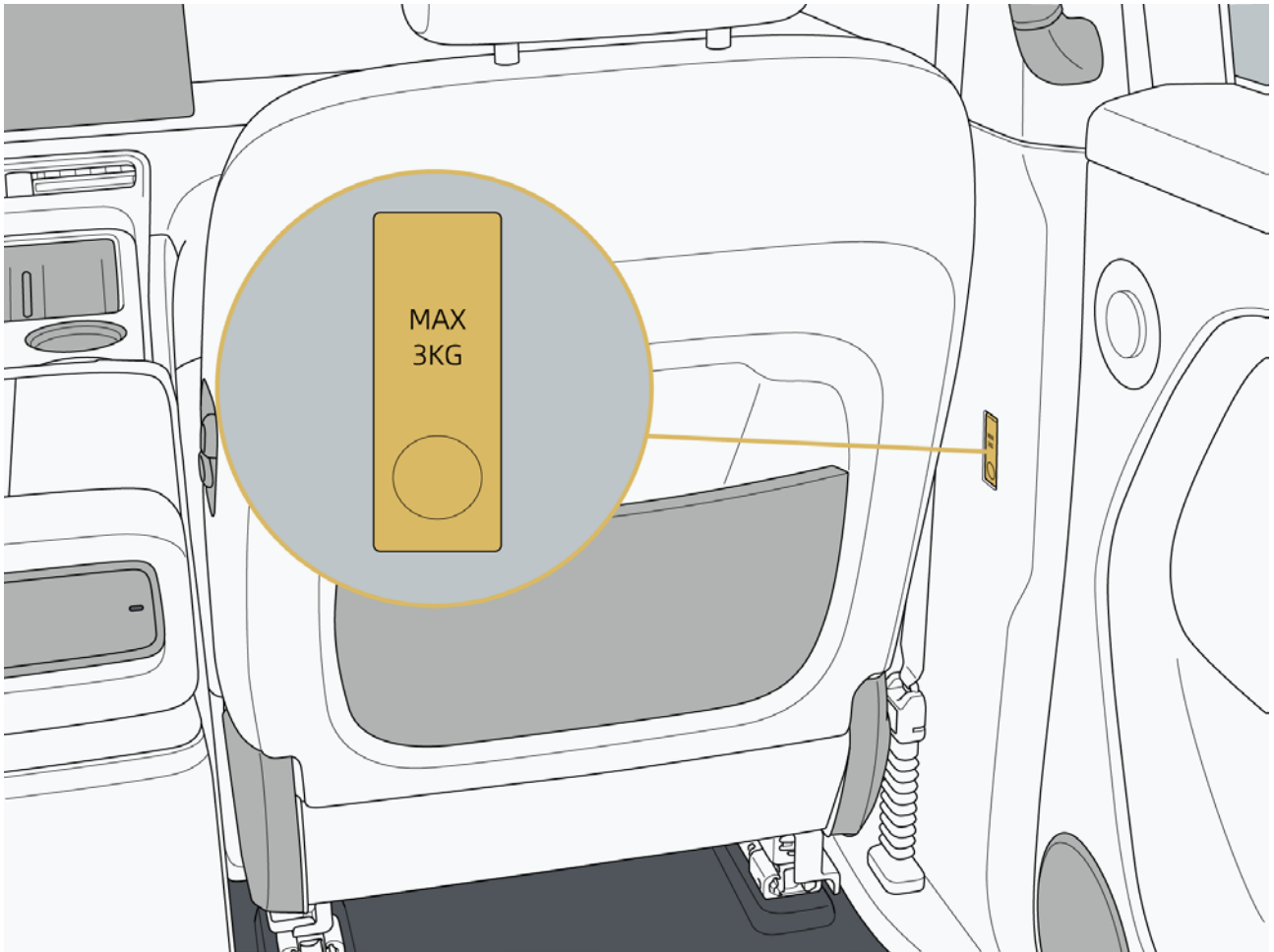

6.9.6 Luggage rack

In order to ensure driving safety and avoid damage to the roof, please use the roof rack approved by ROX.

Before loading items (such as bicycle, ski, etc.) with the roof rack, first install a transverse support bar, and then fix the load on the transverse support bar.

I. Luggage rack loading

Click "Vehicle Settings → Vehicle → Mode" through the central control screen, and then click "Luggage Loading" to turn on/off the luggage loading function.

After activating the luggage rack loading function, switch the vehicle gear to P and close all doors. The suspension height will automatically adjust to the target height, making it convenient to place items on the luggage rack.

Hint

- When the vehicle speed exceeds 5km/h or the luggage rack loading function is turned off or the vehicle height is manually adjusted, the luggage rack loading function will automatically exit.

When loading items on the roof rack, follow the following rules:

- Distribute load evenly to avoid overweight on one side.
- Place the heaviest part of the load in the middle of the roof as much as possible.
- Once the transportation is over, immediately remove the transverse support fixing bar installed on the roof rack.
- The loaded items will increase the sensitivity to side wind effects. Please drive with caution.

Caution

- The maximum loading mass of roof rack: 100 kg. When calculating roof load, it should include the roof rack and any cargo tools.
- Do not exceed the maximum loading mass of the roof rack.
- If the height exceeds the maximum loading height, make sure to control the speed according to the road surface conditions to avoid damaging the roof rack.
- Comply with the relevant national transportation regulations when transporting super-long and super-wide items.
- If you have to load your vehicle on the roof rack, take special care when driving the vehicle and make sure that the items are securely secured.
- The load of the roof rack shall not exceed the maximum axle load and gross vehicle weight.
- Be sure to fix the object to the side rail, not just the cross rail.

6 Operation

- It is recommended not to drive off-road when there are items on the roof. If you need to place items in the luggage rack during off-road driving, you should unload the items before passing the side slope.

6.9.7 Fridge

The vehicle is equipped with a fridge, which can provide you with functions such as preservation, cooling or heating.

I. Control the fridge through central control screen

Click "Vehicle Settings → Accessories → Fridge" on the central control panel to adjust the functions such as temperature, preservation mode or operation mode through this interface.

1. Click the switch to open the fridge door.
2. Click the switch to turn the fridge on or off. Switch between cooling or heating modes.
3. Slide left and right on the screen to adjust the temperature of the fridge.
4. Click to select the fridge preservation mode.
5. Click to turn on or off the function of automatically activating the fridge when getting on the car.
6. Slide left and right on the screen to customize the closing time of the fridge.
7. The fridge control panel is not available after opening the child lock; Click the child lock switch again to close the child lock.

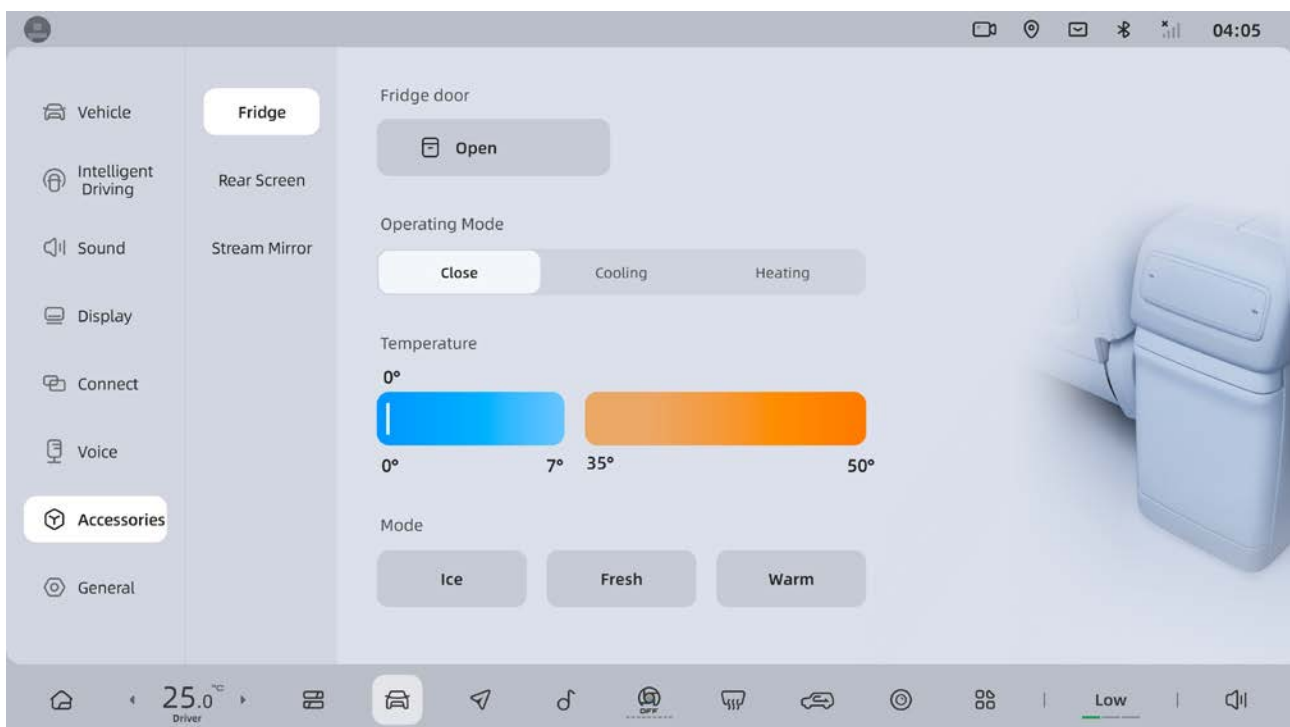

6 Operation

II . Control panel controls the fridge

1. Click to start the cooling/heating mode; Press continuously for 2 seconds to turn off the cooling/heating mode.
2. Click to start the fridge's cooling mode; Short press again to switch between the ice mode and fresh mode.
3. Click to lower or increase the fridge temperature, and long press to continuously adjust the fridge temperature.
4. Click to activate the heating mode of the fridge; Short press again to switch between heating mode and warming mode.
5. Click the switch to open the fridge door.

Hint

- Long press the temperature+ and temperature- keys on the control panel for 3 seconds to lock the child lock. In the child lock state, long press the temperature+ and temperature- keys on the control panel for 3 seconds to unlock the child.
- The continuous operation function of the fridge after you leave the vehicle will consume the vehicle's power, and when the pure electric range is less than 10km, the fridge will stop working.
- The fridge door has a protective function. If the fridge door is opened continuously 10 times within 15 seconds, the button function of the fridge will be disabled for 30 seconds.

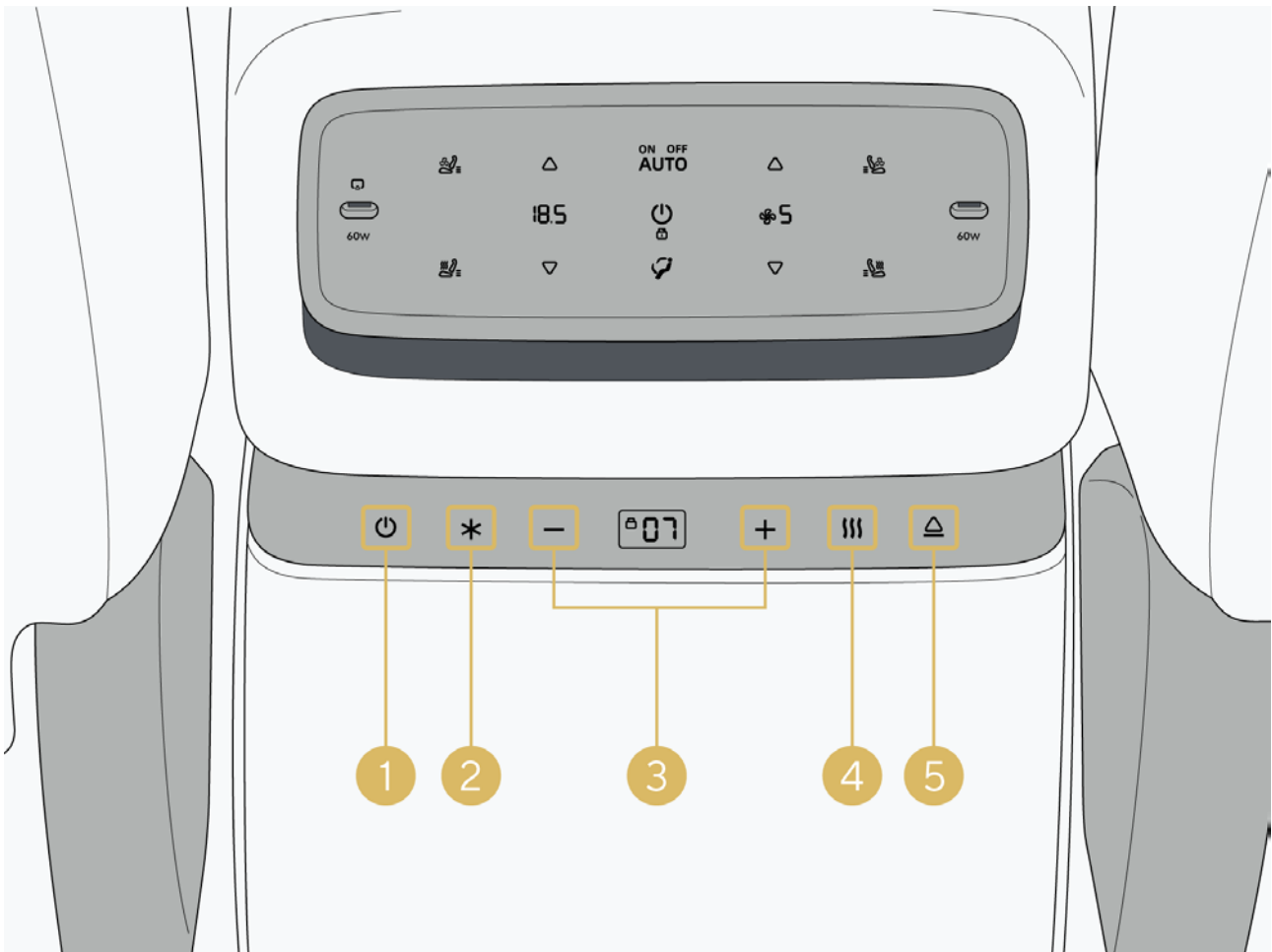

III. Manually close the fridge door

Push the fridge door inward for a certain distance and it will close.

⚠ Caution

- Do not place heavy items in the fridge to avoid damaging it.
- The fridge door is electrically opened. Do not forcefully open it manually to avoid damaging the fridge.
- If any items fall into the opening and closing path of the fridge door, please clean them in time to avoid blocking the fridge door.
- During vehicle operation, do not open the fridge door for a long time, as emergency braking or turning may cause items inside the fridge to fly out.

i Hint

- Please pay attention to the storage conditions and shelf life of stored items or foods, and clean them regularly to avoid expiration and decay.
- Please do not place fragile items in the fridge to avoid damage.

6 Operation

- When the fridge function is turned on, if the fridge door is opened for more than 2 minutes, the fridge will emit a sound prompt.

6.10 Other onboard equipment

6.10.1 Sunshade

1. Front shielding: Turn down the sunshade and place it in the front position.
2. Side shielding: Turn down the sunshade first, then take off the hook and rotate it to the side.

i Hint

- Open the vanity mirror cover and the vanity lamp is up. Close vanity mirror cover, and the vanity mirror lamp is off.

6.10.2 Vanity mirror

Open the vanity mirror cover to use the vanity mirror.

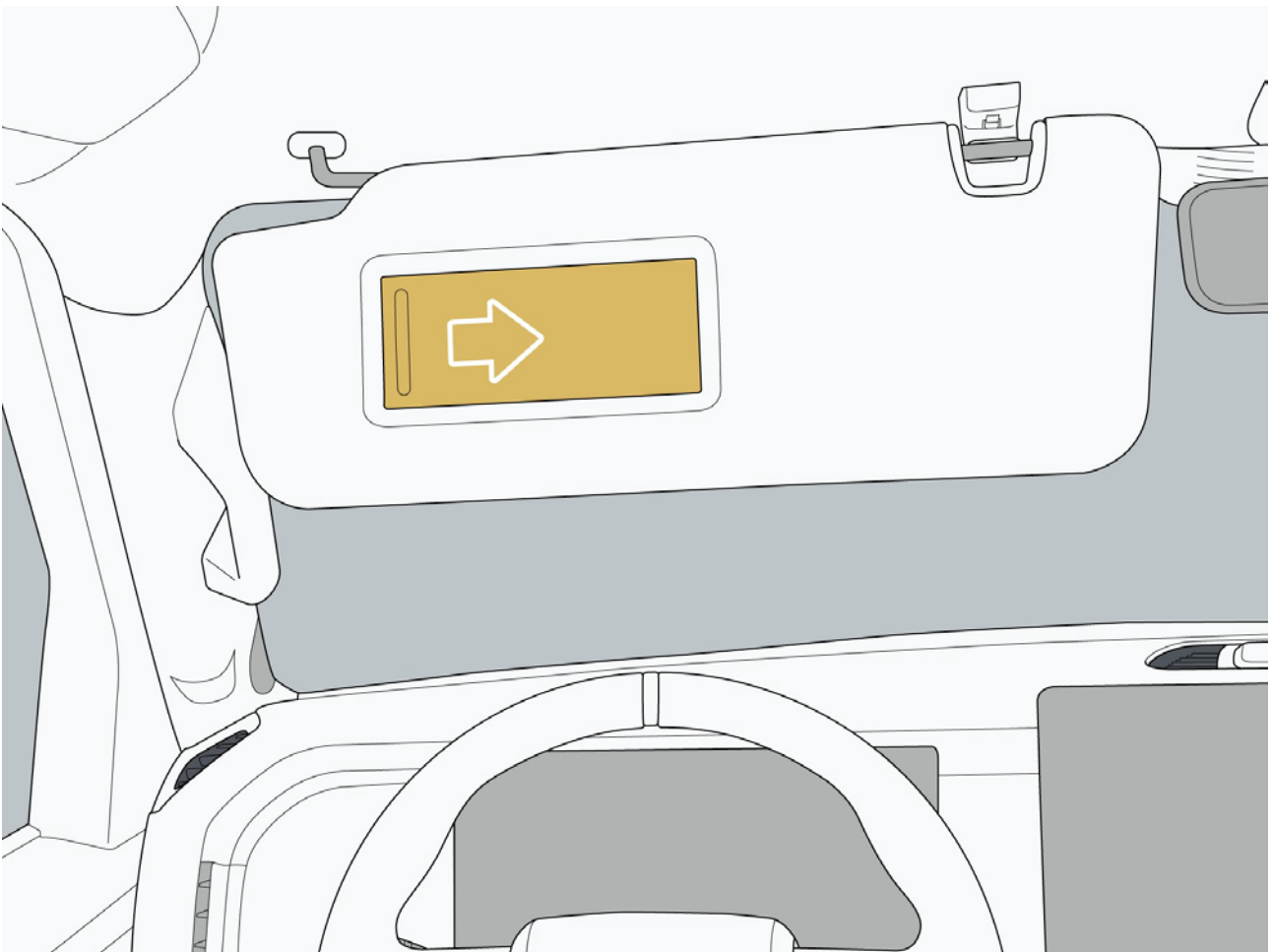

6 Operation

6.10.3 12 V power socket

The 12V power socket in the car can supply power to electronic devices (such as small onboard vacuum cleaner and onboard air pump). The storage slot under the center console is equipped with a 12V power interface, with a maximum output power of 120W.

Warning

- Do not use electrical equipment with a power exceeding 180 W on 12 V power sockets, to avoid burning fuses or lines due to excessive current, and causing fire.

Hint

- When the 12 V power socket is not in use, close the power socket cover to avoid damage caused by foreign objects or liquids entering the power socket.

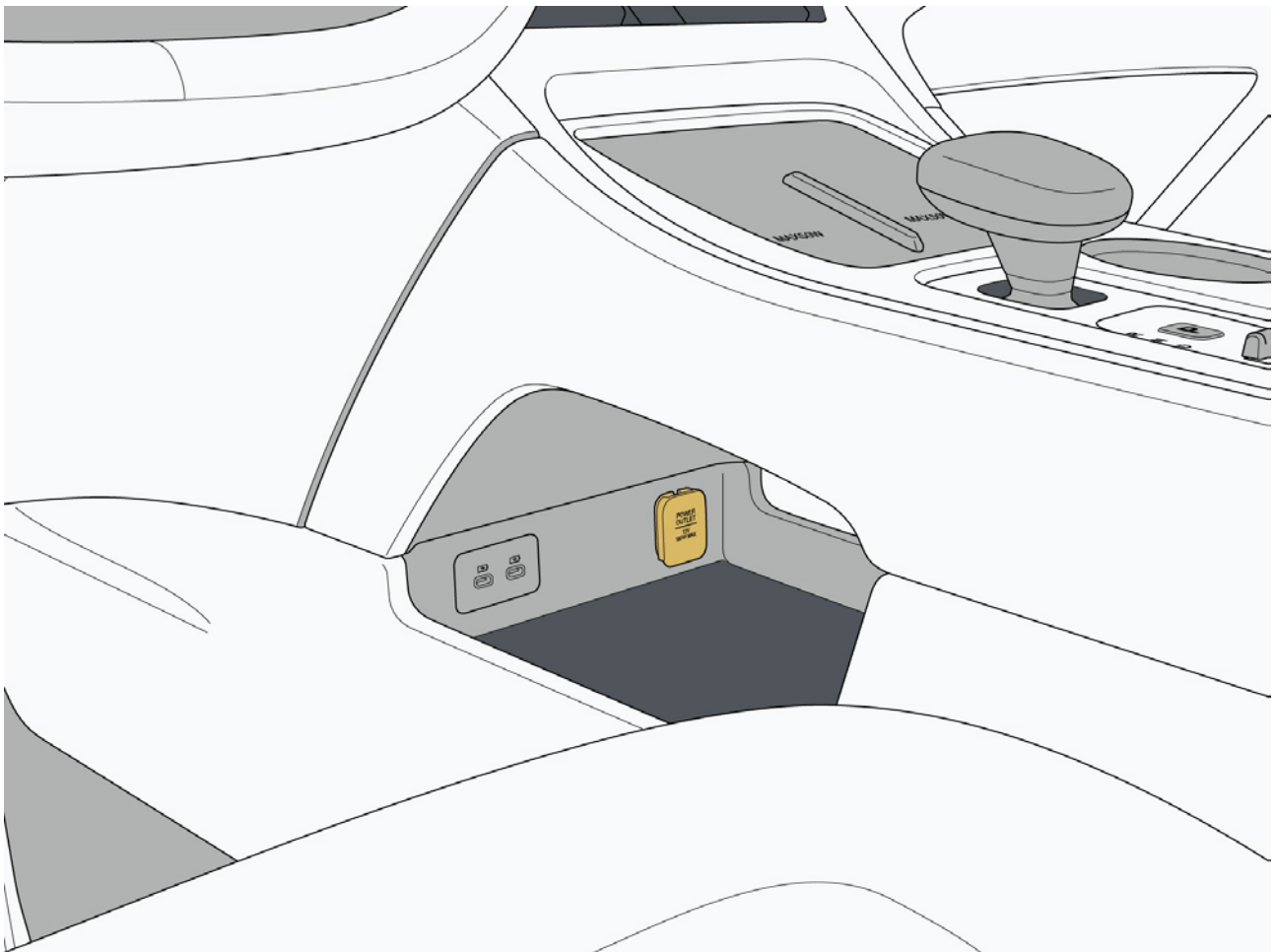

6.10.4 220 V power socket

The 220 V power socket is in the trunk. A 220 V power socket can be used to supply power to electrical equipment with a rated working voltage of 220 V and a maximum power of no more than 2,200 W. The 220 V power socket will automatically turn off or cannot be turned on if:

- The power battery level is too low.
- The 220 V power supply automatically turns off after the vehicle is locked and powered off.
- The vehicle power supply is in "OFF" mode.
- The power of the electric device is too high.
- The system is faulty.

Warning

- Do not use equipment with a power exceeding 2,200 W on a 220 V power socket, to avoid burning the line or even causing fire due to excessive current.
- Keep children away from 220 V power sockets to prevent from inserting fingers or objects into the sockets, which may cause electric shock or damage the outlets.

Hint

- When the 220 V socket is not in use, close the power socket cover to avoid damage caused by foreign objects or liquids entering the power socket.
- Plugging in the overloaded electrical appliance and starting and stopping frequently may trigger the 220 V power socket to enter the protection mode. If the 220 V power socket is not available, unplug the electrical appliance and wait for a period of time and re-plug the electrical appliance to try to start the 220 V power supply.

6 Operation

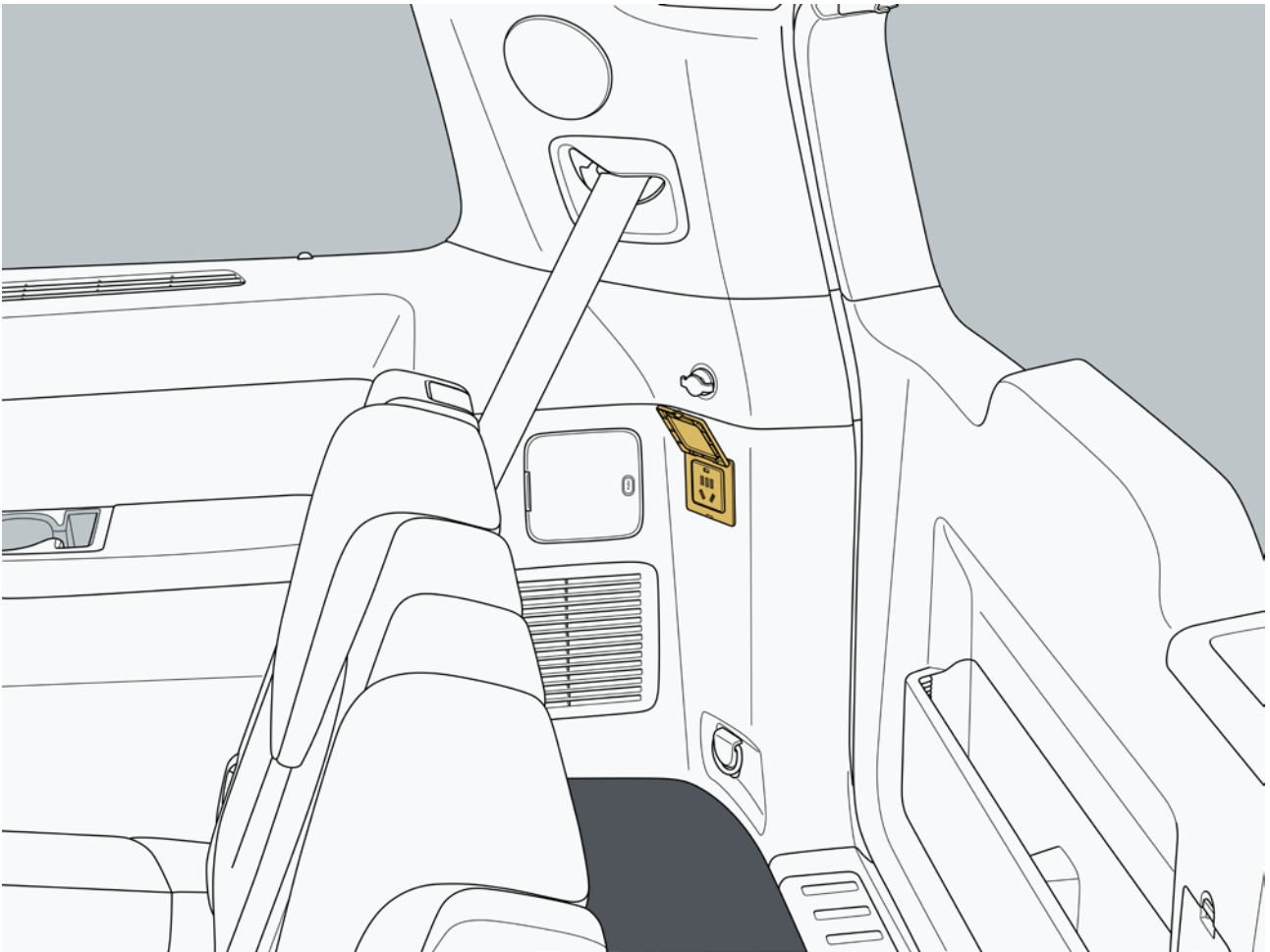

I. Activate/deactivate

Click "Battery Management → Discharge Management → Power Socket" through the central control screen to set the turning on and off of the 220 V power socket.

6.10.5 Wireless charging

By using a wireless charging locker, you can charge your phone when the vehicle is powered on. Before use, make sure your mobile phone has wireless charging function.

Click "Vehicle Settings → Accessories → Wireless Charging" through the central control screen. Click the "Driver" or "Front Passenger" switch to set the wireless charging function of the driver or front passenger to turn on and off.

If you encounter an abnormal wireless charging reminder on the central control screen during use, you can handle it in the following ways:

- Abnormal high temperature: Please suspend use and remove your phone, and use this function again after the charging locker cools down.
- Foreign object: Please place your mobile phone upright and check if there are any metal objects, NFC keys or cards (such as bank cards, transportation cards, ID cards or various access cards, etc.) placed in the charging area;
- If the phone case is thick or contains metal parts, please remove the phone case and use this function again.
- Voltage and other abnormalities: Please contact ROX Service Center in time.

Caution

- When the driver is not in the vehicle, please do not leave your mobile phone in the car for charging, so as to avoid potential safety hazards.
- During the wireless charging process of the mobile phone, no items are allowed to be placed in the charging locker.

Hint

- When the device is charging, if the driver's door is opened and the driver leaves the seat, the vehicle will give a prompt sound.

6 Operation

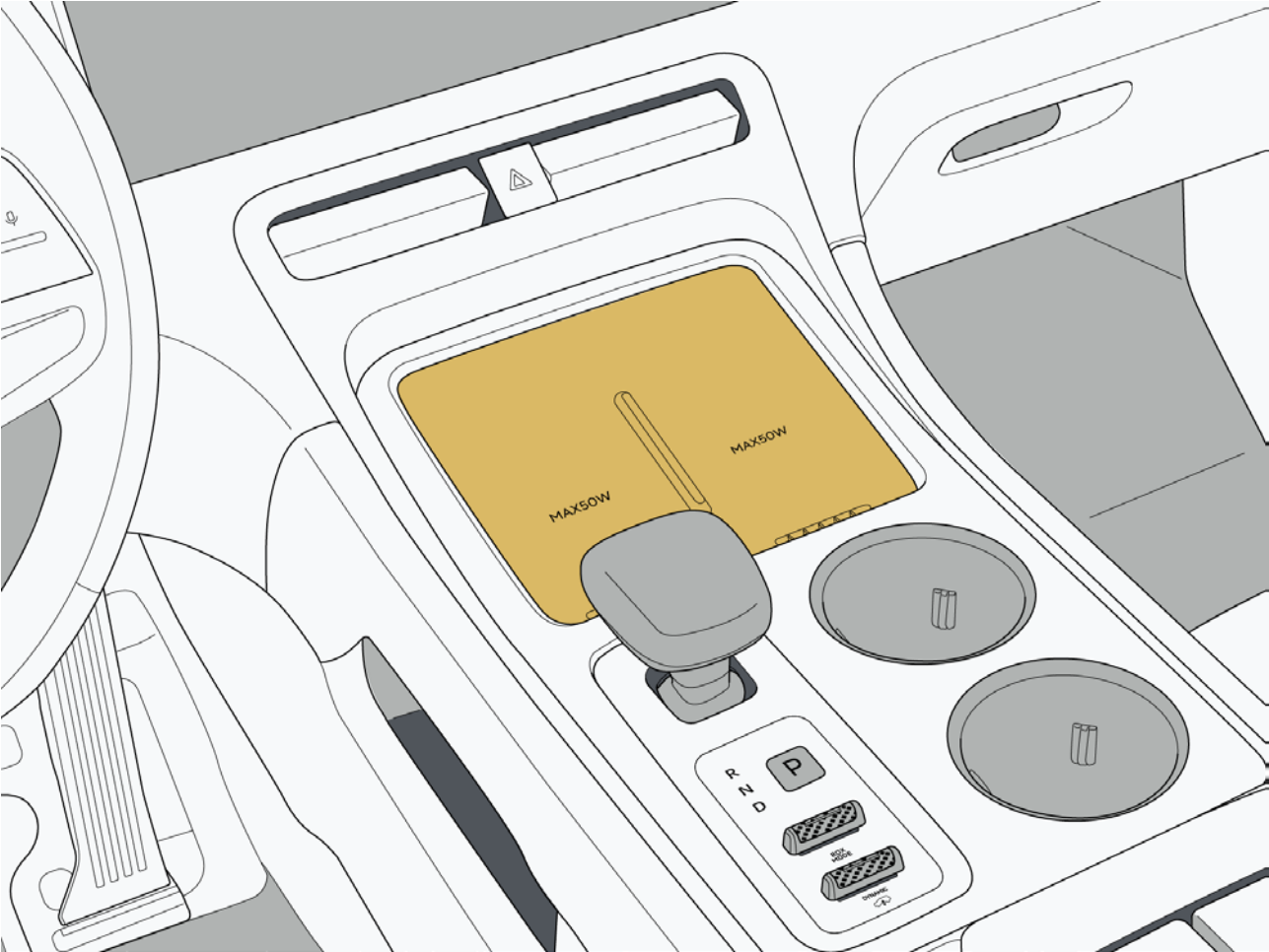

6.10.6 USB/Type-C/Type-A interface

The vehicle is equipped with multiple USB/Type-C interfaces for data transmission, mobile phone charging or providing power for other devices.

I . Front row USB/Type-C interface

1. The front-row Type-C interface is located in the storage pot under the center console, with a maximum output power of 18 W.

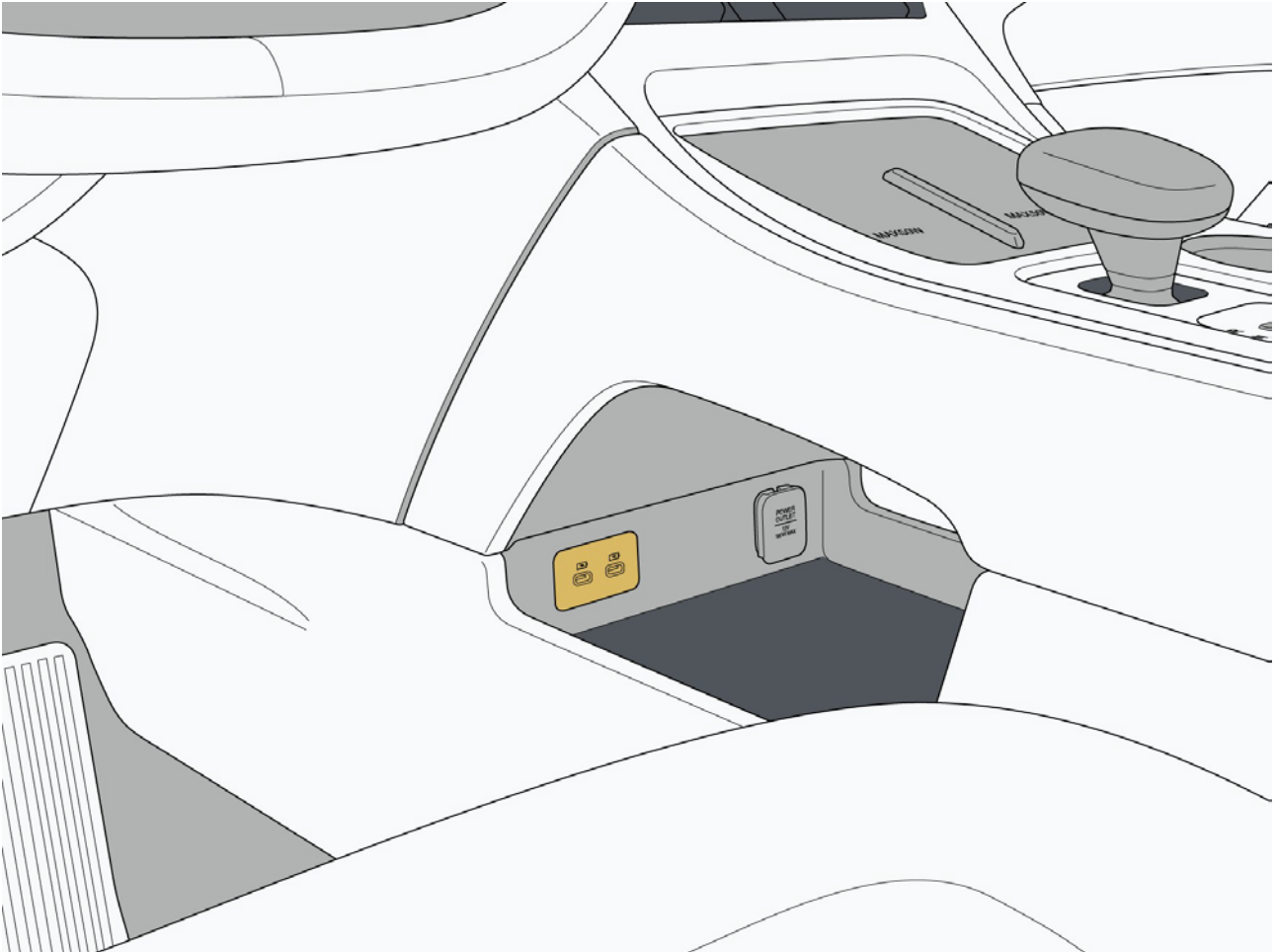

6 Operation

2. The armrest box is equipped with a TF (DVR) interface and a Type-A interface, which are used for external storage of the driving recorder and reading the USB drive.

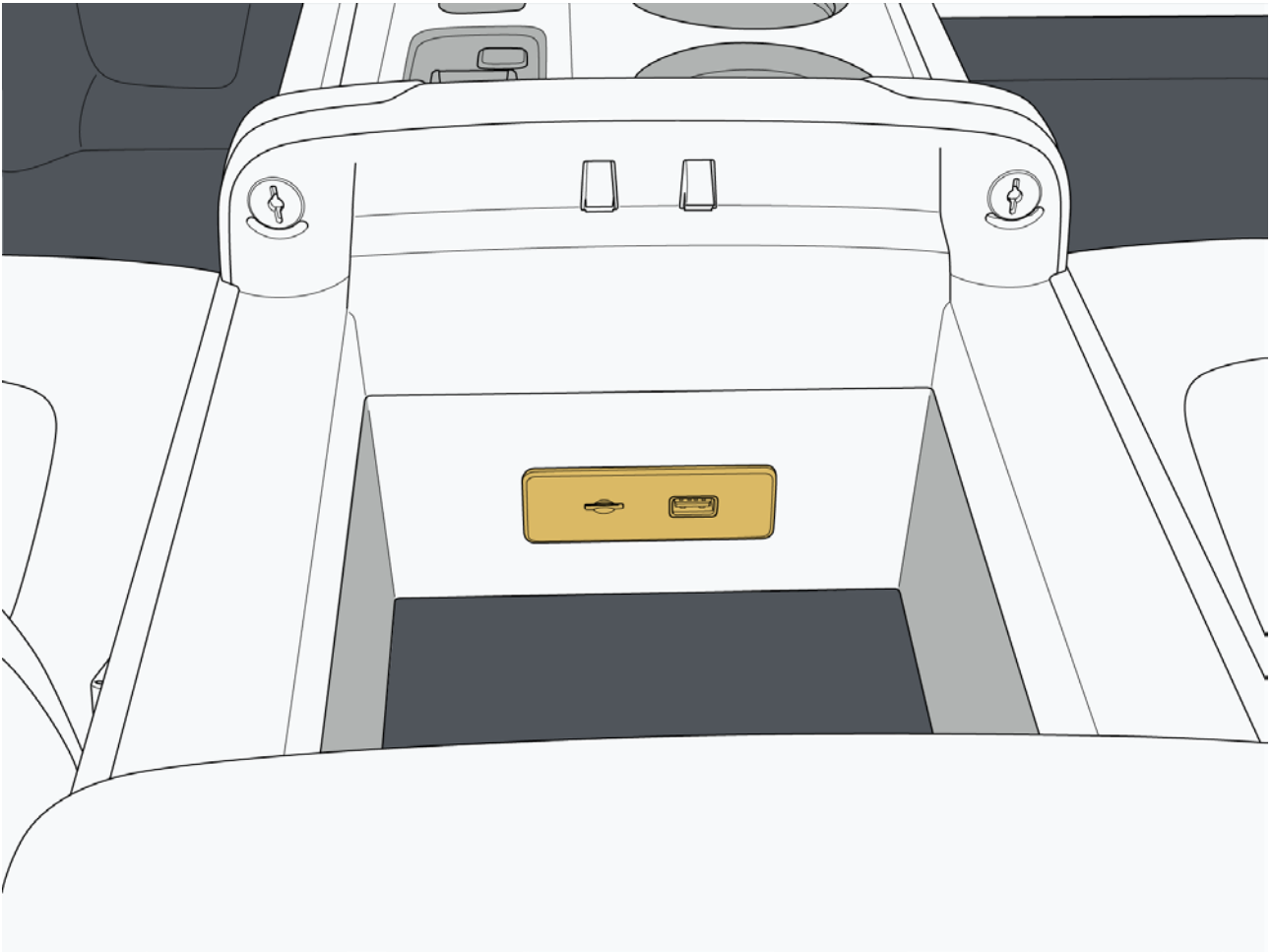

II. Rear Type-C interface

1. There are two Type-C interfaces set at the rear of the armrest box, which can charge mobile devices, and the maximum supporting power is 60W.

Caution

- The Type-C interface at the rear of the armrest box is located at the aisle, and the external USB drive and other equipment may be damaged due to collision, so it is recommended to avoid using it.

Hint

- The Type-C interface on the left supports connecting Switch devices.

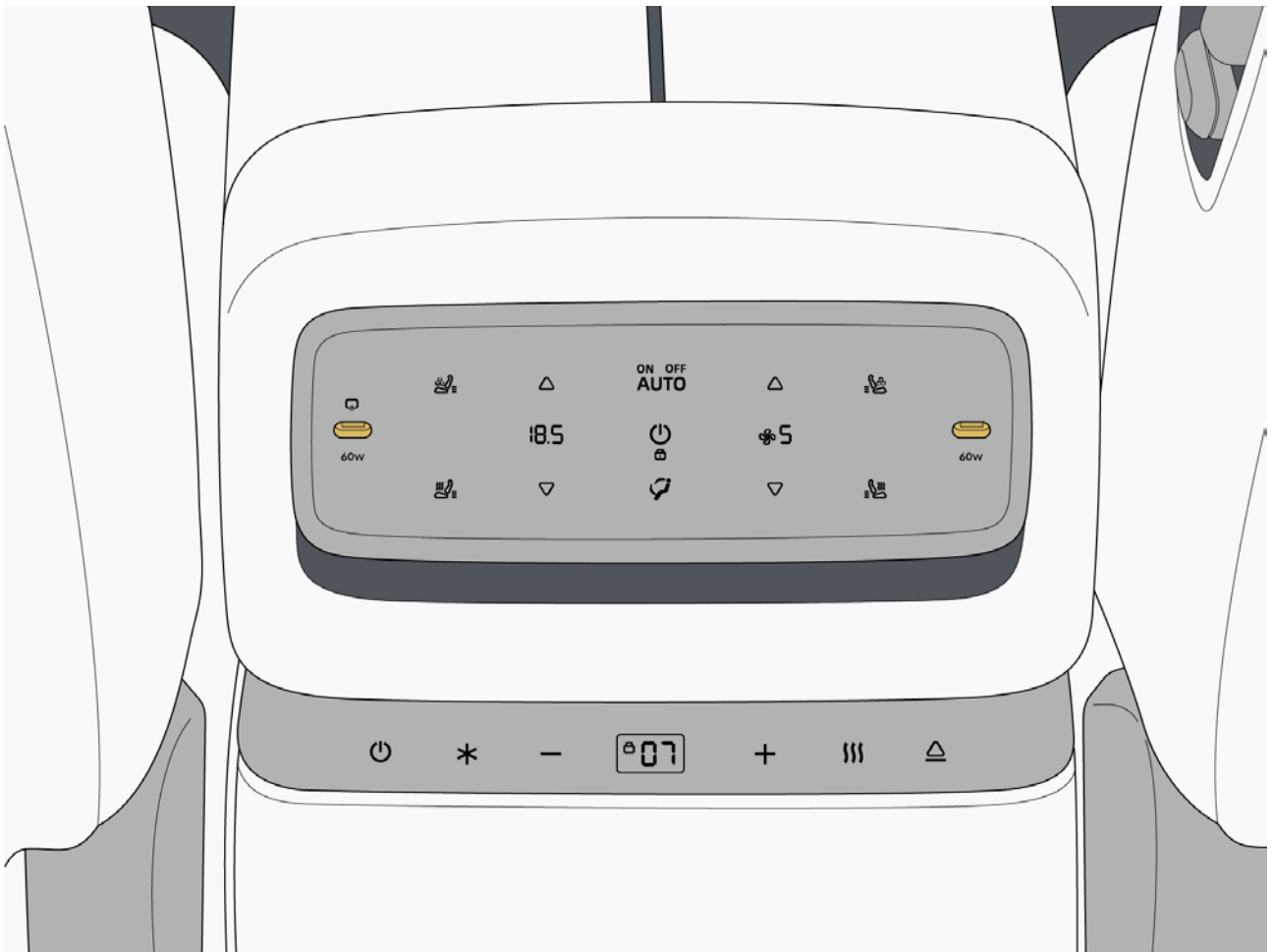

6 Operation

- The Type-A interface is located on the side of the second-row aviation seat (if equipped).

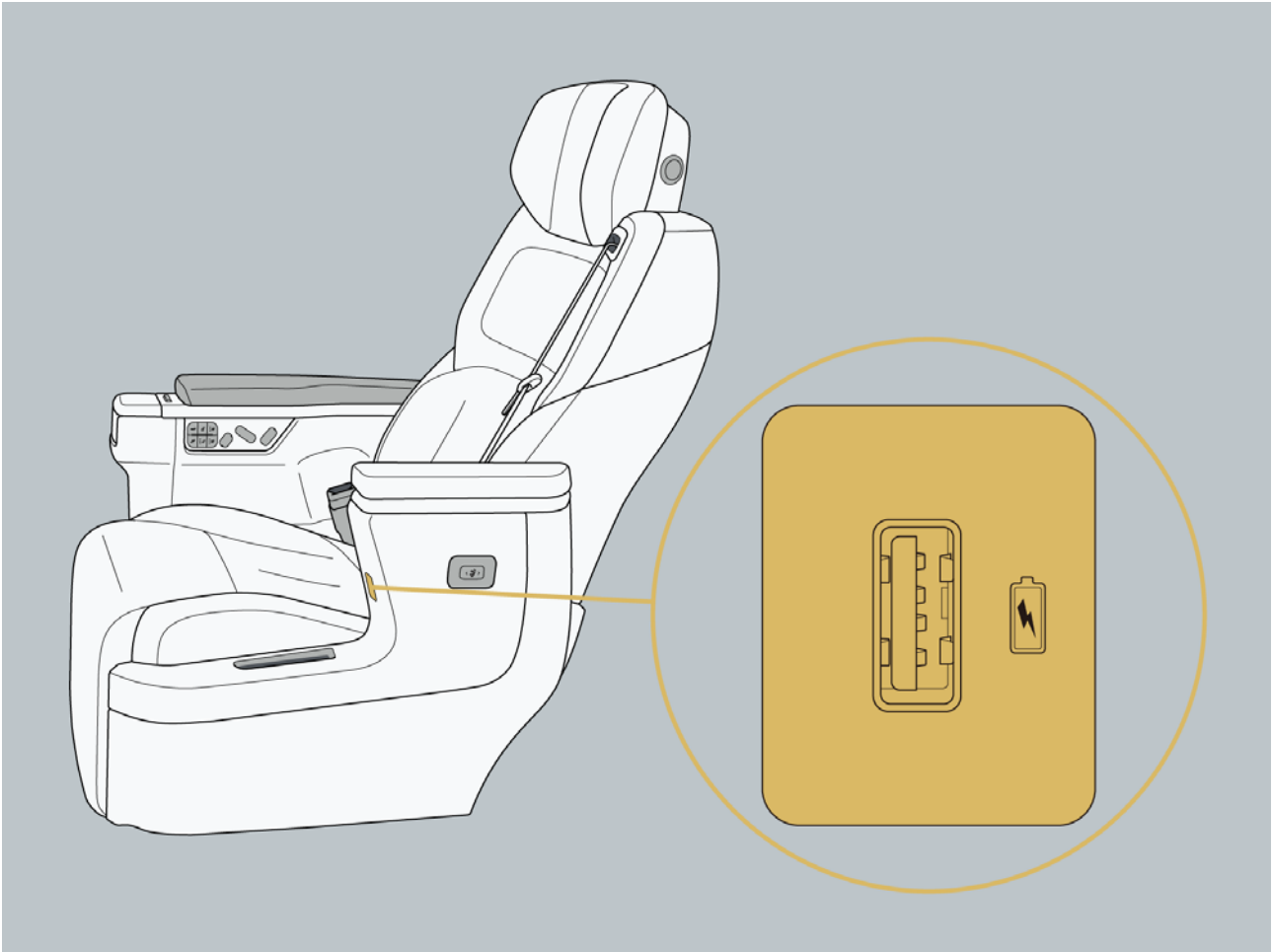

III. Type-C interface in the third row

1. The third-row Type-C interface is located above the armrests of the left/right seats, with a maximum output power of 18 W.

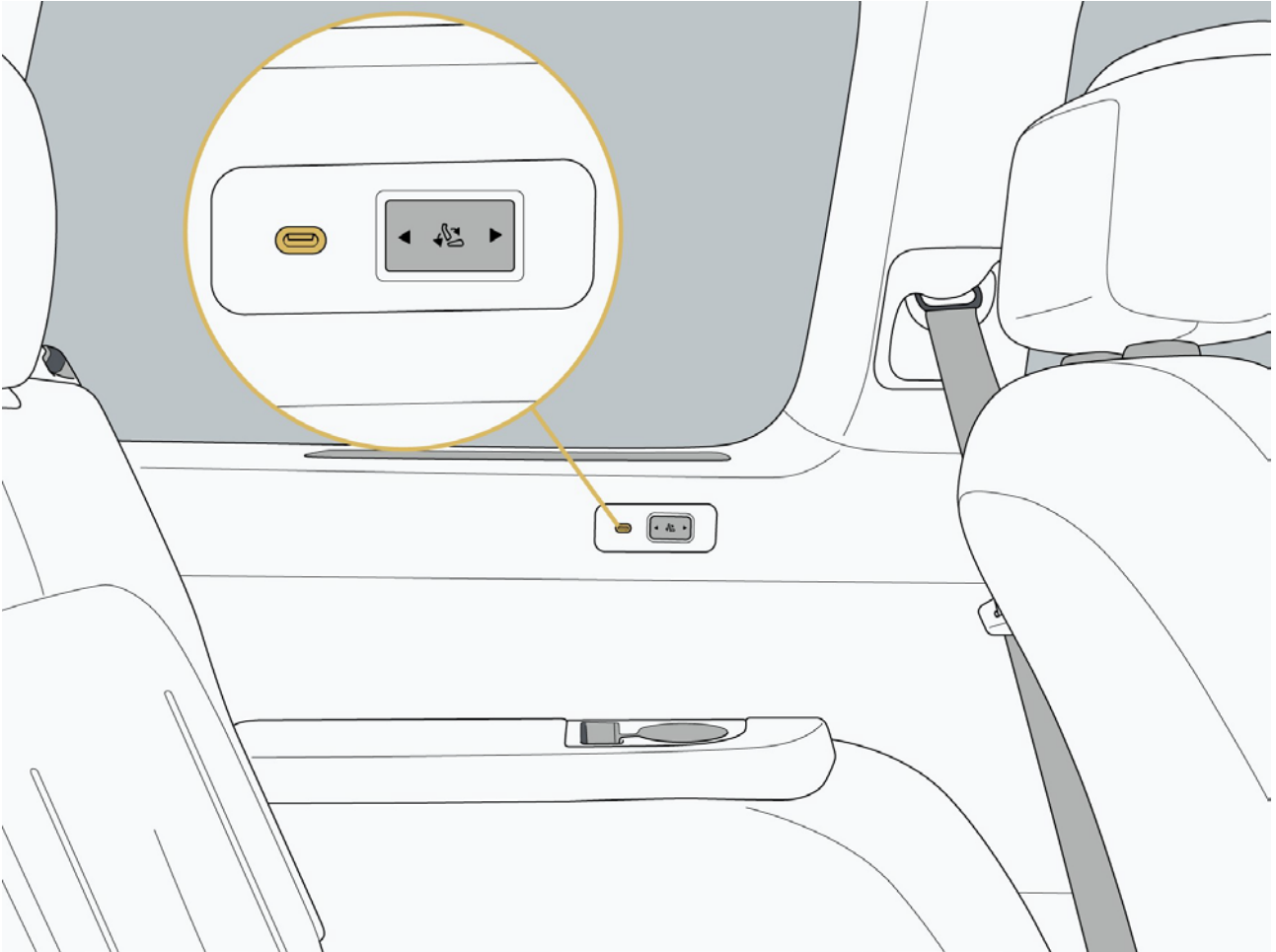

6 Operation

6.10.7 Driving recorder

I. Interface instruction

Click "Driving Recorder" through the central control screen to enter the driving recorder interface:

- Real-time picture: Display the picture recorded by the current driving recorder.
- Album: Click to enter the album to view and manage photos, videos, emergency videos, sentinel views and collections.
- Settings: Click to enter the driving recorder settings interface.

II. Cycle recording

When the vehicle is powered on, the driving recorder will start automatically to enter the cycle recording, and record circularly based on the set cycle recording duration. The cycle recording duration is 5 min, 3 min and 1 min respectively.

III. Emergency recording

During driving, the vehicle will enter the emergency recording in case of a collision. The driving recorder will record video images of a period of time before and after the collision, and record instantaneous photos at the time of the collision.

Hint

- Recorded video files are stored in the album.
- According to requirements of data security regulations, pedestrian facial features and license plate information outside the vehicle belong to private information and are protected. If you need to use and share driving images, please abide by the requirements of laws and regulations.
- Short press the steering wheel customization button to trigger the emergency recording of the driving recorder.

IV. Driving recorder settings

Click "Settings" through the driving recorder interface to enter the driving recorder setting interface.

- Auto-recording upon startup: When the power supply of the complete vehicle is in the "READY" mode after turning on, the driving recorder is enabled and starts recording.
- Driving information superposition: After turning on, the driving recorder interface or preview interface will display the speed information, location and other information in the video.
- Sound recording: It is in "Off" by default. Video files will contain audio when turned on.
- Recording angle: Select the recording angle of driving recorder.
- Video resolution: The driving recorder video resolution defaults to 1080p. 1080P or 720p can be set.
- USB drive management: Display the occupancy of the current capacity by videos and photos in the flash drive.

- Formatting: Click the icon to pop up the prompt box. Then click the prompt box "OK" icon to format the flash drive.

6.10.8 Microphone

The complete vehicle is equipped with 4 microphones. They are located next to the reading lamps in the front row and next to the assist grips on the left and right sides. During the call or voice dialog control scenarios, they record the sound in the car.

Caution

- Do not insert sharp objects into the microphone mesh cover to avoid damaging the microphone.

6 Operation

6.10.9 Assist grip

When the vehicle is moving rapidly or shaking, occupants can maintain their body balance through the assist grip. When using the roof assist grip, ensure to extend the armrest for proper use. When not in use, just release it, and it will automatically return to its stored position.

Warning

- Do not hang heavy objects or place heavy loads on the assist grip to avoid damage.

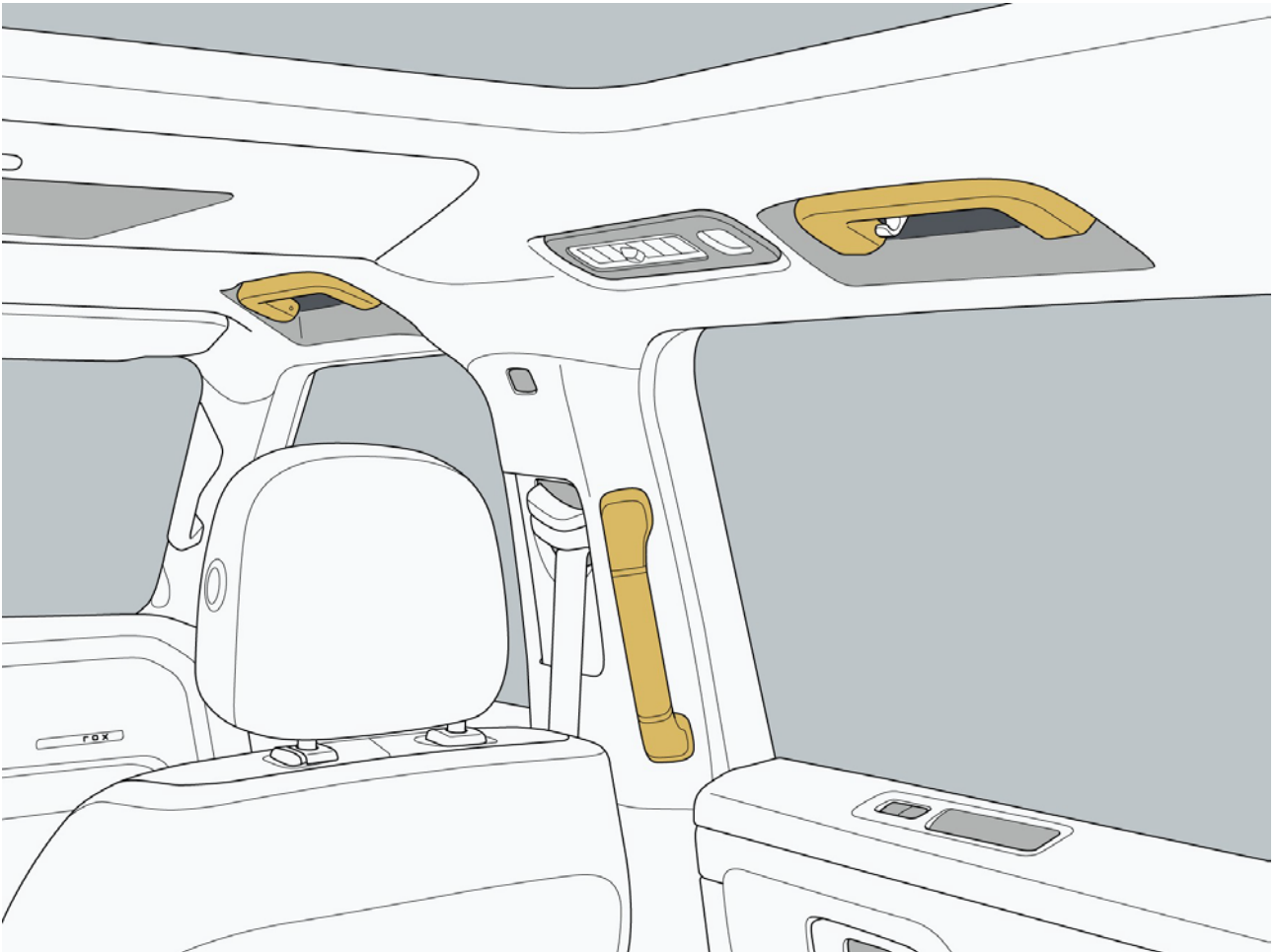

6.10.10 Coat hook

There are coat hooks attached to the roof assist grips above both sides of the second-row seats, which are only used to place coat and hat items.

Warning

- Do not hang other hard items on the coat hook. When the side air curtain is unfolded, these items may pop out and result in an accident.

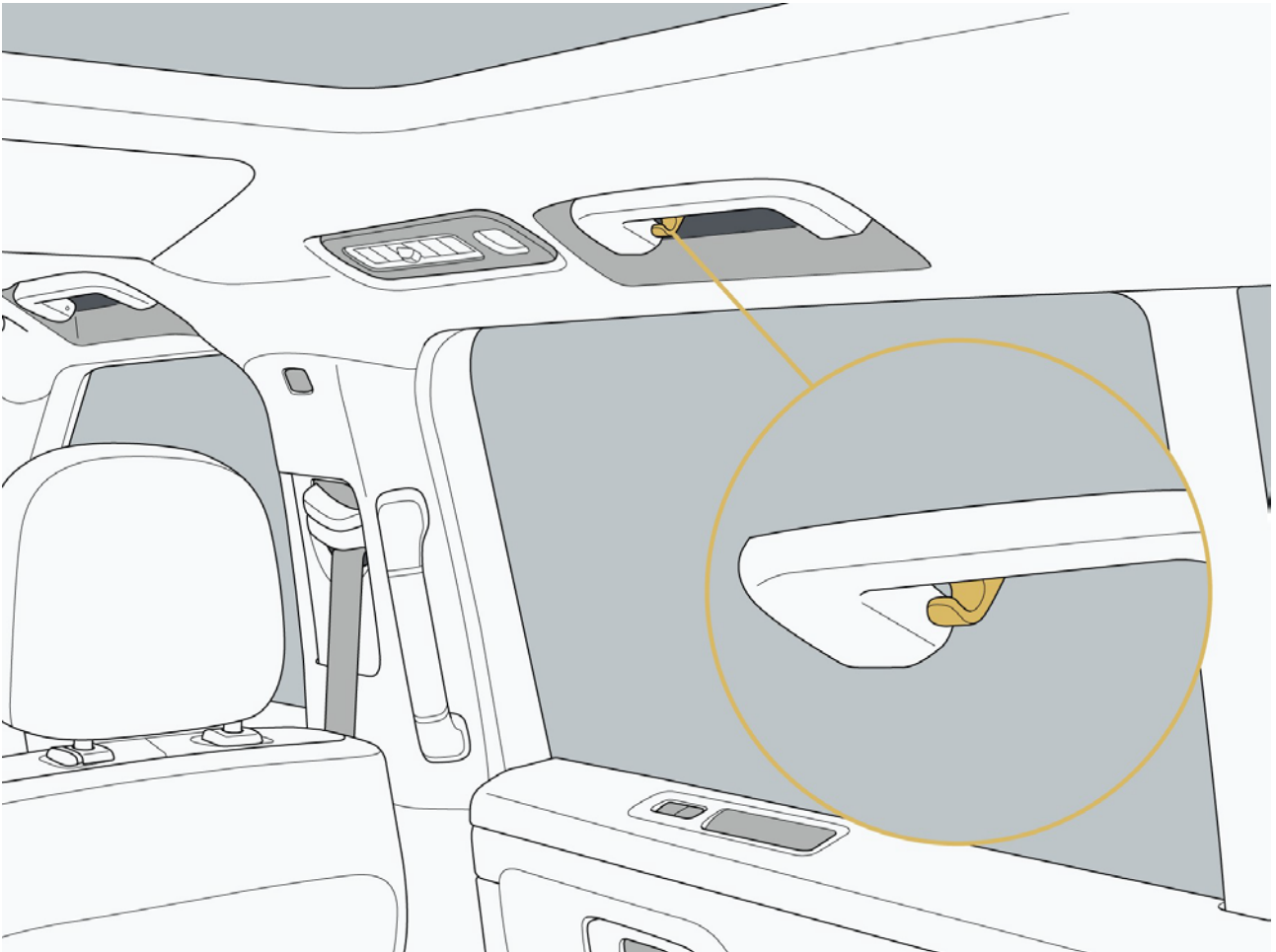

6 Operation

6.10.11 Magnet track lamp

There is a magnet track lamp on the right side of the trunk. When the magnet track lamp is aligned with the slot, it can be charged. The magnet track lamp can be removed and used as a flashlight.

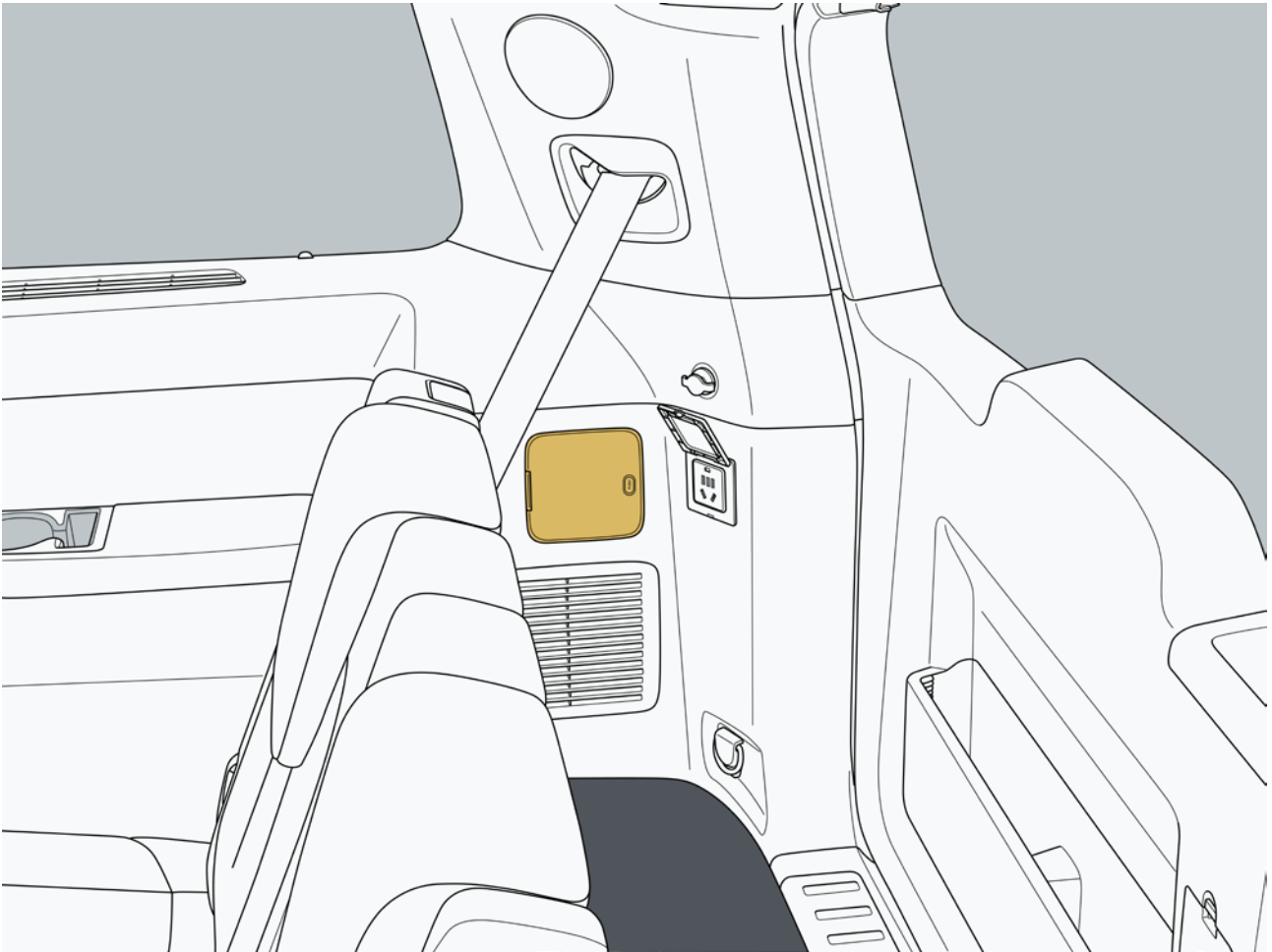

7.1 Before driving

7.1.1 Driving vehicle

1. Pre-trip inspection

Before traveling, confirm that there is no battery system alarm information on the instrument screen. If there is a failure of the power battery system, you should immediately contact the ROX Service Center for inspection.

2. Start the vehicle

Carry the remote key, depress the brake pedal, and the "READY" indicator on the instrument screen is on. At this time, the vehicle is drivable.

3. Vehicle starting

After starting the vehicle, switch the gear to D position, gradually release the brake pedal, and gently depress the accelerator pedal to accelerate the vehicle.

4. Parking

Depress the brake pedal to stop the vehicle completely. Switch the vehicle gear to P gear, and close and lock all doors.

Warning

- Do not operate the shift handle at will while the vehicle is driving. This can avoid accidents caused by sudden shift of gears.
- Do not depress the accelerator pedal when operating the shift lever. This can avoid traffic accidents or casualties caused by sudden acceleration when switching gears.
- Do not drive on a road section where the depth of stagnant water is unknown. This can avoid damaging electrical parts or the range extender.
- Do not protrude any part of your body out of the car while driving.
- Do not run the range extender system for long time in a poorly ventilated or closed place to avoid exhaust gas poisoning.
- Do not excessive idle when any tire is suspended or the vehicle is stuck in sand or mud. This can avoid accidents caused by sudden acceleration.
- Do not park your vehicle near flammable and explosive materials to avoid causing fire.
- Do not put fragile items in storage devices to avoid damage to items due to bumps.
- Do not apply sudden braking, rapid acceleration, or sharp steering on slippery surfaces to prevent reduced or complete loss of vehicle control.
- Do not drive over flammable materials, and avoid damaging the vehicle or even causing a fire due to flammable materials burning.

7 Driving

- Do not stop on a ramp by using the accelerator pedal or depressing the accelerator pedal and brake pedal at the same time.

Caution

- When going down a steep slope, it is recommended to use the hill descent control to maintain a stable speed.
- When driving on a bumpy road, it is recommended to drive at a low speed to avoid damaging wheels or the bottom of the vehicle.
- When the vehicle needs to wade, check the water depth first to ensure that the vehicle can pass safely. After passing safely, gently depress the brake pedal to keep the brakes dry, and make sure that the brake system works properly.
- After driving on a wading road and the vehicle enters water, drive the vehicle to the ROX Service Center for inspection.
- Flat or damaged tires can cause the vehicle to sound abnormally, vibrate, difficulty to control, or tilt abnormally. When the tire is flat or damaged, you need to hold the steering wheel firmly and depress the brake pedal slowly.

7.1.2 Cargo and luggage

Items placed in the trunk can be fixed with a luggage retaining ring to avoid damage to items due to vehicle shaking or affecting driving safety due to luggage shaking.

Warning

- Do not store fragile, flammable and explosive dangerous articles in the trunk to avoid fire, explosion or article damage.
- Do not drive the vehicle when the load is unevenly distributed. This can avoid losing the balance of the vehicle when turning.
- Be sure to secure the cargo in the trunk. Otherwise the cargo may be thrown into the compartment during emergency braking.
- Do not drive the vehicle when it is overloaded. This can avoid accidents caused by excessive inertia and excessive braking distance.

7 Driving

7.1.3 Traction mode

The car towing assembly is a spherical coupling conforming to regulation ECE R55, which can support towing accessories (such as trailer, RV, bicycle, etc.).

Towing a trailer and carrying accessories can increase vehicle weight and drag. As a result, range can be significantly reduced when towing a trailer. Although the vehicle mileage calculator attempts to adjust the mileage estimate based on the mounting bracket, the actual energy consumption may vary. You need to reasonably plan the trip length and destination before traveling.

To install and use the accessory bracket, a towing device must be attached. Follow the instructions provided by the attachment bracket, and comply with all local regulations and legal requirements applicable to carrying attachments.

The vehicle towing assembly includes wiring required to be equipped with lamps for the accessory bracket. When towing attachments, regularly confirm that the attachment bracket and its cargo are always in a safe state. Also confirm that the lamps on the attachments are working properly.

Warning

- Do not install an accessory bracket on the vehicle that is not equipped with towing assembly.
- When loading and towing, comply with applicable local laws and regulations.

Caution

- The towing device may obscure the view of the exterior rearview mirror, rear camera and rear ultrasonic-wave sensor. In addition, some assist driving functions may not work properly.
- Make sure to use a suitable disconnect towing cable or secondary hitch. For guidance, refer to the trailer manufacturer's instructions for use.

Hint

- After connecting the towing device, the vehicle body height is automatically adjusted to the standard. During the connection of the towing device, speed adjustment and height adjustment are not available. After disconnecting the towing device, when the vehicle speed exceeds 5km/h or the height is manually adjusted, the suspension will adjust to the new target height according to the current mode.
- Check the operation of all towing lamps before departure.
- Make sure the towing ball is securely fixed.

I. Towing capacity

Maximum towing capacity (including all cargo and additional equipment) and vertical carrying weight of the towing hook shall not exceed the following values: Maximum towing capacity of the vehicle, maximum load bearing capacity of the towing hook:

Tire	Maximum towing capacity (maximum towing weight)	Maximum load capacity of the hook (maximum vertical weight of the trailer tongue)
20", 21"	750 kg	75 kg

The hook load capacity is the downward force exerted by the trailer weight on the hitch mechanism. When driving a trailer with a C6 driver's license, the total mass must be less than (not equal to) 4,500 kg, including the mass of the trailer and the mass of the vehicle. Loading a large amount of equipment or cargo in a trailer reduces its towing weight, which also reduces the maximum towing capacity.

Warning

- Do not allow the vehicle or towing trailer to exceed the maximum load capacity to avoid vehicle damage caused by accelerated wear and tear.
- Loading the vehicle beyond its maximum capacity will adversely affect its stability and braking performance, leading to loss of control and increased braking distances, and potentially causing serious accidents.
- When calculating the load weight on the rear axle, keep in mind to add the load weight on the tow nose, the load in the vehicle luggage compartment, the weight on the roof rack and the weight of the passengers in the rear seats together.

II. Tire pressure during towing

Adjust the tire pressure to accommodate the additional load during towing.

The technical allowable maximum mass on the rear axle during towing does not exceed 1,797 kg. Under these circumstances, the speed must not exceed 80 km/h, and the rear tire pressure must be at least 20 kPa to 30 kPa higher than the normal recommended tire pressure.

Warning

- If there is a tire failure in the vehicle, do not attempt to tow a trailer. A temporary repaired tire cannot withstand the towing load. Towing with faulty or temporarily repaired tires can lead to tire failure and loss of vehicle stability.

7 Driving

III. Operation before towing

The following operations must be performed before towing:

- Inflate the tires to the specified cold tire inflation pressure for towing.
- Understand and comply with all local legal and regulatory requirements for towing.
- Adjust the rearview mirror to ensure that there are no obvious blind spots.

Before towing, please confirm the following:

- Driving vehicle with a trailer requires holding a locally recognized and valid driver's license.
- The vehicle must be level when connecting the towing device. If the front of the vehicle is upward inclined and the rear is downward inclined, make sure that it does not exceed the maximum towing capacity and tow hook bearing weight provided in the "Towing Capacity" table.
- All trailer components, accessories, and electrical connectors are in good condition and properly connected. Do not tow if there are any obvious problems.
- The trailer tongue is firmly connected with the tow ball device.
- All cargo is secured.
- The vehicle stoppers are available.
- The tow load is evenly distributed to ensure the trailer tongue weight is approximately 4% of the total trailer weight and does not exceed the maximum trailer tongue bearing weight provided in the "Towing Capacity" table.

Warning

- Always make sure the cargo is secured in the trailer and will not move. Dynamic load movement may cause the vehicle to lose control, resulting in serious injury or death.
- The trailer tongue weight is approximately 4% of the total trailer weight and does not exceed the maximum trailer tongue bearing weight provided in the "Towing Capacity" table. An unbalanced load on the wheels or a heavier load at the rear may lead to loss of vehicle control.
- The towing weight shall not exceed the total weight of the vehicle, the maximum rear axle mass and the maximum trailer mass.
- After loading, the towing trailer should be parallel to the ground.

IV. Towing guidance

The vehicle is primarily designed for passenger transport. Towing a trailer will impose additional loads on the vehicle's motor, transmission system, braking system, tires and suspension, significantly reducing the driving range. When it needs to tow a trailer, operate carefully and follow these guidelines:

- Reduce driving speed and avoid sudden manoeuvring. When towing a trailer, compared to driving without a trailer, steering, stability, turning radius, stopping distance and braking performance are all different.

- Avoid sharp turns, as it may cause the trailer to touch the vehicle and cause damage. As trailer wheels are closer to the inside of the turn than the vehicle wheels, turn wider to prevent the trailer from hitting curbs, road signs, trees, or other objects.
- Stay at least twice as far away from the vehicle in front of you to increase the following distance. This helps avoid emergency braking. Sudden braking may cause skidding or bottom damage as well as loss of control.
- Regularly check whether the cargo is secure.
- Regularly check whether the trailer brakes are working properly.
- Avoid parking on slopes.
- Regularly confirm that all towing parts are firmly tightened.
- During towing, no personnel are allowed to ride in the trailer.
- Place heavy objects in the trailer as close to the axle as possible to reduce swaying interference during the towing.

Warning

- Always ensure that all trailer wheels are securely with stoppers when parking on a slope. Otherwise, it may lead to severe vehicle damage, personal injury or death.

V. Parking during towing

It is recommended to park the vehicle on a flat surface with a slope not exceeding 12%. If it is necessary to park on a slope, place wheel stoppers under the trailer wheels:

1. One person depresses and holds the brake pedal.
2. Another person places the stoppers under the wheels on the downhill side of the vehicle's tires.
3. When the stoppers are in place, release the brake pedal and ensure the stoppers can withstand the weight of the vehicle and trailer (if Autohold is not enabled).
4. Put the vehicle in P gear and activate the electronic handbrake.

Warning

- Always ensure that all trailer wheels are securely with stoppers when parking on a slope. Otherwise, it may lead to severe vehicle damage, personal injury or death.

7 Driving

VI. Electrical connection

Trailers are equipped with taillamps, brake lamps, side indicators and turn signal lamps. To power the trailer lamping system, the vehicle has a built-in 13-pin electrical connector installed in the middle of the rear bumper. The electrical connector can connect most of the trailer wire plugs. If the electrical connector of the towing truck (trailer) is a 7pin electrical connector, you need to purchase an adapter.

Pin number	Function	Pin number	Function
1	Left turn signal lamp	8	Reverse lamp
2	Right fog lamp	9	No output
3	Pin 1-8 ground	10	12 V power output when the vehicle is awakened
4	Right turn signal lamp	11	Pin 10 ground
5	Right taillamp	12	Interfaces reserved for future configuration
6	Brake lamp	13	Pin 9 ground
7	Left taillamp		

Warning

- Do not attempt to directly splice or use any other method to connect the trailer's wiring. Otherwise, it may damage the vehicle's electrical system and cause faults.

Caution

- Before towing and during towing, check and ensure that all electrical connections are working properly, and all trailer lamps are functioning correctly.
- Make sure that the trailer wires are not contacting with or dragged on the ground, and allow for turning space for the wires.

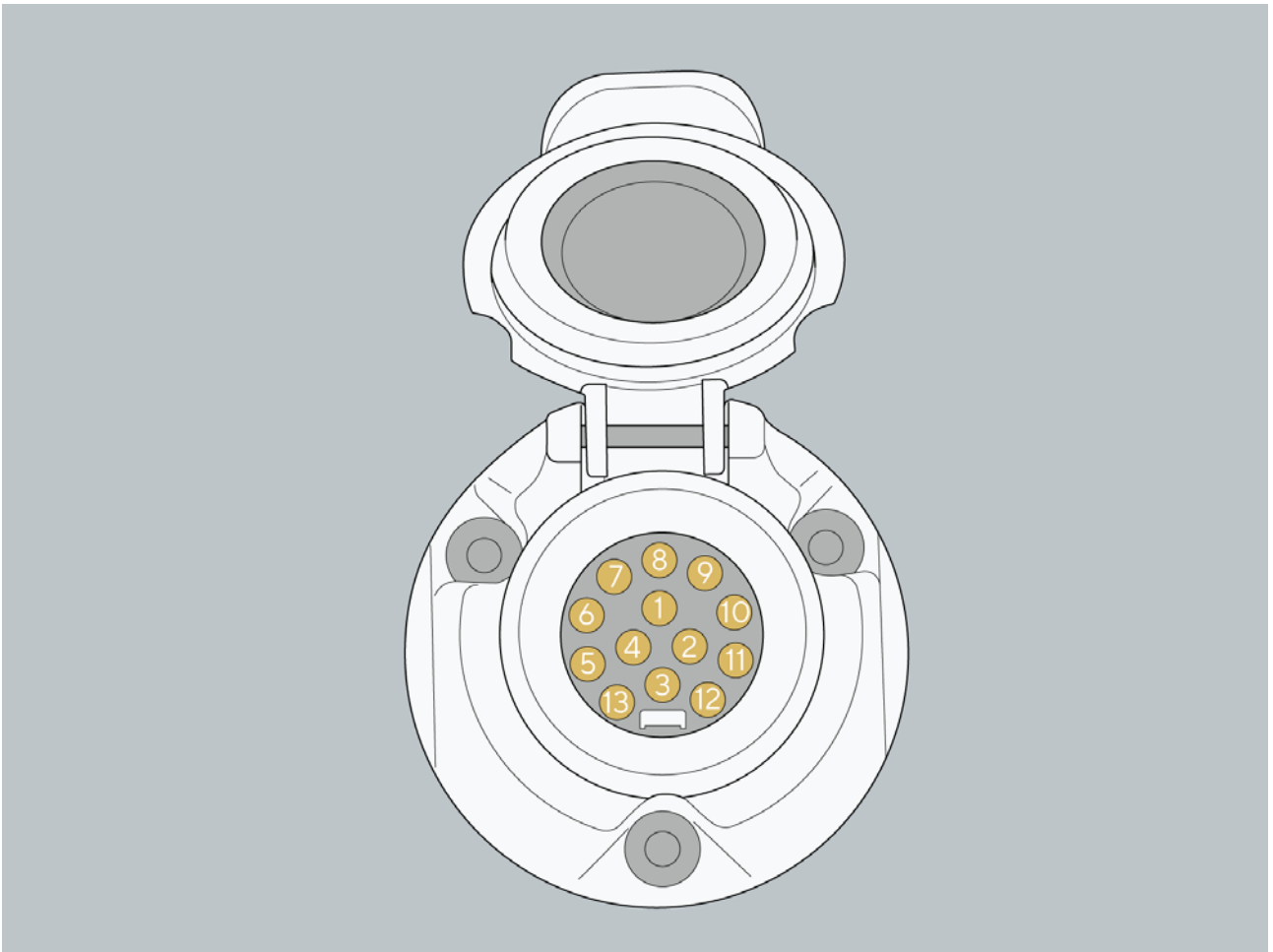

7 Driving

7.2 Driving specification

7.2.1 Power mode switching

I. Vehicle power-on

"ON" mode: All vehicle electrical appliances are powered on and operational, but the vehicle cannot be started to drive. In the "OFF" mode, you can switch to this mode by opening any door with a valid remote key or Bluetooth key.

"READY" mode: The vehicle is in a drivable state. You can switch to this mode by depressing the brake pedal with a valid remote key or Bluetooth key.

Hint

- When the vehicle is started and in P gear, if the driver's side door is detected to be open and the driver leaves the seat, the vehicle will automatically switch from "READY" mode to "ON" mode.

II. Vehicle power-off

"OFF" mode: All vehicle electrical appliances are turned off. You can switch to this mode by closing all doors and locking the car.

7.2.2 Gearshift mechanism

The gearshift mechanism used in this vehicle is an electronic gearshift handle, which has 4 gear positions: P, R, N and D.

I. Operate the shift handle

The vehicles power is in the “READY” mode. Depress the brake pedal. Move the handle forward or backward to the specified position to switch gears.



II. Gear use

Gear	Function
P	Parking
R	Reverse
N	Neutral
D	Drive

7 Driving

III. Gear switch

- P (Parking Gear): When the vehicle speed is below 5 km/h, press the P gear button, and the vehicle enters P gear.
- R (Reverse Gear): When the vehicle speed is below 5 km/h, depress the brake pedal, and push the handle forward to R gear.
- N (Neutral Gear): When the vehicle speed is below 5 km/h, depress the brake pedal, and push the handle to N gear.
- D (Drive Gear): When the vehicle speed is below 5 km/h, depress the brake pedal, and push the handle to D gear.

Warning

- During driving, if an emergency occurs (such as brake system failure), press and hold the P gear button to activate the dynamic parking function. The vehicle will decelerate within a certain range until it stops. Release the P gear before the vehicle stops, and the dynamic parking function will exit immediately.
- Ensure the vehicle is in P gear before the driver exiting the vehicle. Do not rely on the vehicle to shift to P gear, as this function may not work in all situations.
- When the vehicle is in neutral (N gear), it may slide. You can press the brake pedal to keep the vehicle stationary.
- If the vehicle cannot shift gears normally, contact the ROX Service Center in time.

Hint

- If the driving speed is too high or the brake pedal is not depressed during shifting, the vehicle will not be able to shift gears.
- The vehicle speed is ≤ 3 km/h, the current gear is not P, the brake pedal is not pressed, the driver's seat belt is not fastened, and the driver's door is open, the gear will automatically return to P.

7.2.3 Turn signal light control

Lane Change: Move the turn signal control lever up or down to position 1, and the turn signal lamp and the instrument panel turn indicator will flash three times.

Steering: Move the turn signal lamp control lever up or down to position 2, and the turn signal lamp and the instrument panel steering indicator will continuously flash. Again pull the turn signal lamp control lever up or down to position 1, and the turn signal lamp and the instrument panel turn signal indicator will turn off.

i Hint

- If the turn signal lamp flashes quickly, it indicates a fault with one of the vehicle's turn signal lamps. Please go to the ROX Service Center for maintenance promptly.

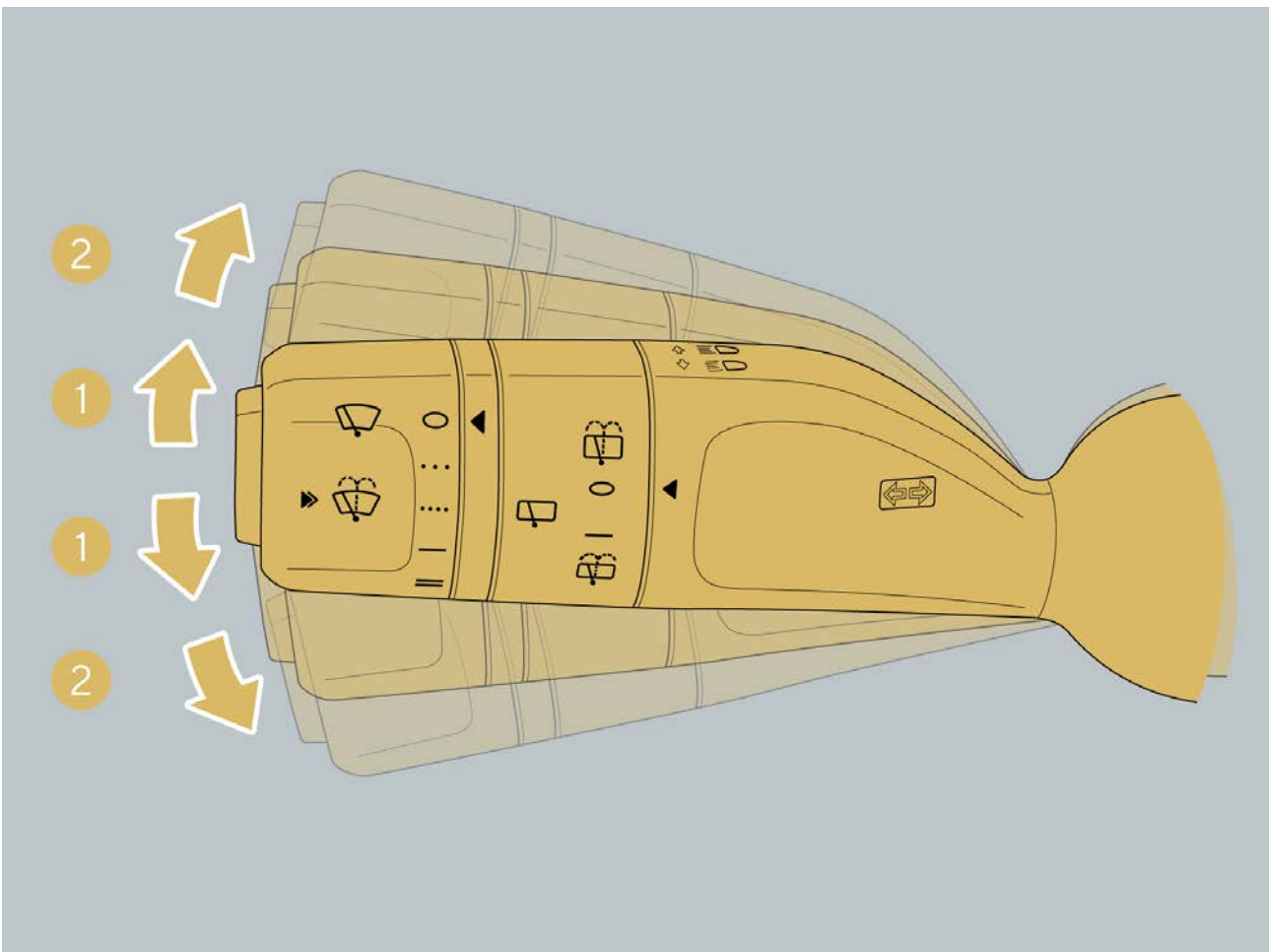

7 Driving

7.2.4 Low-speed pedestrian warning sound

The low-speed pedestrian warning sound is used to alert other road users (including pedestrians, bicycles, etc.). When the low-speed pedestrian warning sound is enabled, the vehicle automatically determines whether to send a warning sound based on the vehicle speed information.

Click "Vehicle Settings → Vehicle → Driving → Low-Speed Pedestrian Warning Sound" through the control screen to set the low-speed pedestrian warning sound: Off/Engine/Sci-Fi.

Caution

- The temporary off function of the low-speed pedestrian warning sound can only be used when there are no other road users in a short distance, and it obviously does not need a warning sound for the surrounding environment.

7.2.5 Special road condition

Click "ROX Mode → Special Road Conditions" through the central control screen, and you can choose between two special road condition modes: Deep Snow and HDC.

- Hill descent control: When the vehicle is going downhill, the hill descent control (HDC) system will automatically intervene. It can apply a certain braking force to the wheels to ensure the vehicle's speed is stable during downhill driving.
- Deep Snow Mode: Applicable to road surfaces that are wet and loose but do not sink.

7.2.6 Tire pressure monitoring system (TPMS)

The vehicle is equipped with a tire pressure monitoring system. It can detect tire pressure information and display the current tire pressure and temperature on the instrument panel. When the tire pressure is too high, too low, or the tire is overheated and rapidly flatting, the tire pressure monitoring system warning lamp will illuminate, and the instrument panel will display related text alerts. When the tire pressure warning lamp appears, please check whether the tire is normal immediately to avoid safety incidents. The following are common fault alarms and solutions:

- Low pressure alarm: Supplement tire pressure to the standard pressure value.
- High pressure alarm: Reduce the tire pressure to the standard pressure value.
- High temperature alarm: Stop driving and check tire pressure.
- Rapid deflation: Stop driving and check if the tire is damaged.

⚠ Caution

- To enhance driving safety, if the tire pressure monitoring system is not functioning properly, contact the ROX Service Center promptly.

ℹ Hint

- The tire pressure monitoring system may be affected by radio waves, which could limit or prevent its normal operation. You can correct the tire pressure information by driving the vehicle away from radio wave devices or changing the frequency that interferes with radio waves.
- After wheel rotation, tire replacement, or tire pressure sensor replacement, please drive to the ROX Service Center to have the tire pressure sensor recalibrated.

7.2.7 Electronically controlled adjustable suspension

The electronically controlled suspension system improves vehicle ride comfort and stability, reduces tire load variation, shortens braking distance, and minimizes body vertical vibration. This resolves the conflict between vehicle handling stability and comfort.

While the vehicle is stationary, you can customize the suspension adjustment mode by clicking "Vehicle Settings → Vehicle → Driving → Suspension Mode" through the control screen.

- Comfort mode: The damping force is relatively small, applicable to paved roads.
- Standard mode: The damping force is moderate, applicable to most roads.
- Sport Mode: The damping force is too large, applicable to high-speed roads.
- ATM: The vehicle adjusts its damping adaptively on slippery, muddy, sandy, rugged, and wading roads based on driving conditions.

I. Suspension height

The vehicle suspension supports height adjustment, thus meeting different driving scenarios. Every time the vehicle is started, the suspension height is defaulted to the corresponding height before the last power off.

1. Adjust the suspension height through the central control screen

Click "Vehicle Settings → Vehicle → Driving → Suspension Height" on the central control screen to select different suspension heights.

- Lift mode: In this mode, the minimum ground clearance of the vehicle is 272mm.
- High: The minimum ground clearance of the vehicle in this mode is 230mm.
- Higher: The minimum ground clearance of the vehicle in this mode is 210mm.
- Standard: The minimum ground clearance of the vehicle in this mode is 190mm.
- Low: The minimum ground clearance of the vehicle in this mode is 175mm.

7 Driving

2. The suspension height is adjusted by the paddle switch
 - The suspension height is adjustable in four levels: By pushing the lever forward or backward, the suspension height can be adjusted up or down by one level within the current mode. The gear sequence is: low, standard (default), high, higher.
 - When the suspension height is high, push forward and long push for 5 seconds to enter the lift mode; In the lift mode, push backward and long push for 5 seconds., the suspension exits the lift mode and its height rises to high.
3. Limitations of air suspension height adjustment
 - The suspension height adjustment function is disabled during intense driving of the vehicle (such as sudden acceleration, sudden braking, sharp turn, and bumpy up and down, etc.).
 - When the vehicle door is open, the suspension height adjustment function is disabled.
 - When the traction mode is activated, the suspension height adjustment function is disabled.
 - When the trailer mode is activated, the suspension height adjustment function is disabled.
 - When the steering wheel angle is too large, the suspension height adjustment function is disabled.
 - When the charger is connected to the vehicle, the suspension height adjustment function is disabled.
 - When regenerating the air dryer, the suspension height adjustment function is disabled.
 - When the camping leveling mode is activated, the suspension height adjustment function is disabled.
 - When the road slope is too steep or uneven, the suspension height adjustment function is disabled.
 - When the suspension maintenance mode is activated or the vehicle is on a lift, the suspension height adjustment function is disabled.

Caution

- Before lowering the height of the air suspension, please pay attention to the surrounding environment of the vehicle to avoid damage to the chassis caused by obstacles under the vehicle. If a serious collision occurs, please contact ROX Service Center in time.
- Before raising the height of the air suspension, please pay attention to the space on the top of the vehicle to avoid the top of the vehicle being squeezed and damaged.
- When the suspension height adjustment is set to "high", intense driving of the vehicle (such as sudden acceleration, sudden braking, sharp turn, bumpy up and down, etc.) should be avoided, as this not only affects driving comfort but may also damage the vehicle.

Hint

- When the vehicle starts, it will automatically check the air suspension system. There will be a slight sound during the process, which is a normal phenomenon. The slight sound will disappear after the self-check is completed.

- During the process of adjusting the vehicle height with air suspension, you may hear the sound of the compressor working, which is a normal phenomenon.
- If the suspension height is frequently adjusted, the compressor will enter a thermal protection state and it will take some time to recover.
- The change of vehicle load leads to the change of suspension height. When the door is closed, the suspension will automatically level the height.
- After a vehicle has been parked for a long time and is restarted, the compressor may need to replenish the air storage system. During the replenishment process, you may hear the compressor working sound, which is a normal phenomenon. After the replenishment is completed, it will automatically stop.
- When a vehicle is restarted after being parked for a long time, the internal pressure of the air springs may decrease, resulting in a decrease in the height of the vehicle. This phenomenon is not a functional failure. When the vehicle restarts and closes the door, the body height automatically returns to the target height.

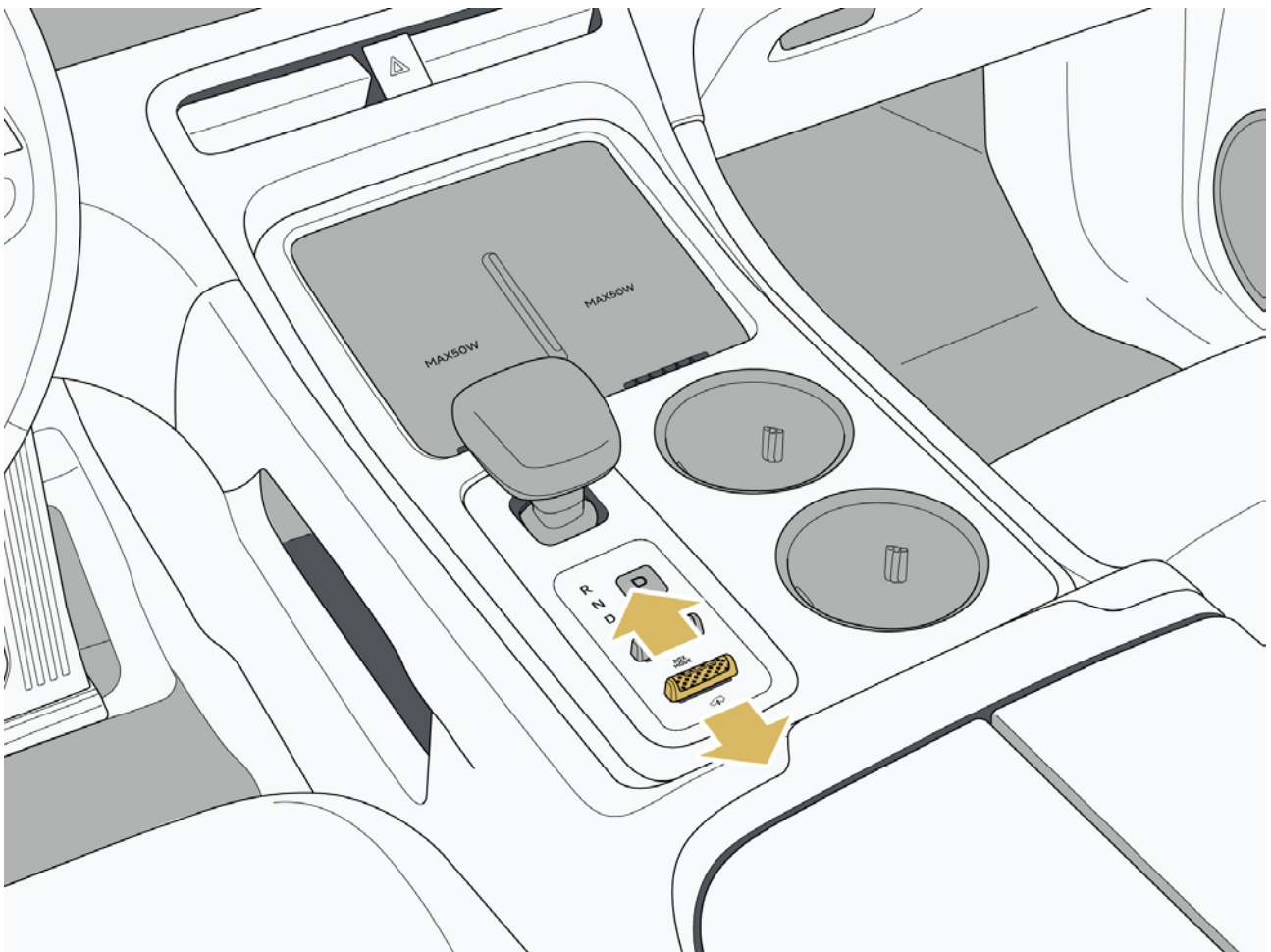

7 Driving

II . Suspension adjustment with speed

The vehicle will automatically adjust the suspension height according to the driving conditions to enhance driving safety and comfort.

The suspension height mode is high

- When the vehicle speed increases to more than 40km/h, the suspension height will automatically adjust to the higher.
- When the vehicle speed increases to more than 80km/h, the suspension height will automatically adjust to the standard.
- When the vehicle speed increases to more than 105km/h and less than 120km/h for 30s or the vehicle speed is more than 120km/h, the suspension height will automatically adjust to the low;
- When the vehicle speed is reduced to less than 80km/h and more than 50km/h for 10s, or the vehicle speed is less than 50km/h, the suspension height will automatically adjust to the standard.
- When the vehicle speed is reduced to less than 40km/h and more than 20km/h for 12s, or the vehicle speed is less than 20km/h, the suspension height will automatically adjust to the higher.
- When the vehicle speed is reduced to less than 20km/h and more than 7km/h for 10s, or the vehicle speed is less than 7km/h, the suspension height will automatically adjust to the higher.
- The suspension height mode is higher:
- When the vehicle speed increases to more than 80km/h, the suspension height will automatically adjust to the standard.
- When the vehicle speed increases to more than 105km/h and less than 120km/h for 30s or the vehicle speed is more than 120km/h, the suspension height will automatically adjust to the low;
- When the vehicle speed is reduced to less than 80km/h and more than 50km/h for 10s, or the vehicle speed is less than 50km/h, the suspension height will automatically adjust to the standard.
- When the vehicle speed is reduced to less than 40km/h and more than 20km/h for 12s, or the vehicle speed is less than 20km/h, the suspension height will automatically adjust to the higher. The suspension height mode is standard:
- When the vehicle speed increases to more than 105km/h and less than 120km/h for 30s or the vehicle speed is more than 120km/h, the suspension height will automatically adjust to the low;
- When the vehicle speed is reduced to less than 80km/h and more than 50km/h for 10s, or the vehicle speed is less than 50km/h, the suspension height will automatically adjust to the standard. The suspension height mode is low
- When the vehicle speed increases to more than 105km/h and less than 120km/h for 30s, or the vehicle speed is more than 120km/h, the suspension height will be further lowered by a certain distance based on the low mode.
- When the vehicle speed is reduced to less than 80km/h and more than 60km/h for 10s, or the vehicle speed is less than 60km/h, the suspension height will automatically adjust to the low.

- Suspension height mode is lift mode:
- When the vehicle speed increases to more than 10km/h, it will automatically exit lift mode, and the suspension height will automatically adjust to the high.

Warning

- The limitation of function of suspension adjustment with speed is the same as that of air suspension height adjustment function.

III. Lift mode

1 Central control screen settings

After the vehicle starts, when the gear is in the P, click "Vehicle Settings → Vehicle → Driving → Body Height Adjustment" on the central control screen, set the height to "High", and click "Lift Mode" to activate the function. The air suspension height will automatically adjust to the lift mode height.

2. Paddle switch settings

After the vehicle starts, when the gear is in the P and the suspension height is high, push forward for 5 seconds to enter the lift mode.

3. After the vehicle enters the "Lift Mode", it will exit the "Lift Mode" if the following conditions are met:

- When the vehicle speed increases to more than 10km/h, it will automatically exit lift mode, and the suspension height will automatically adjust to the high.
- Adjust the suspension height to the high through the central control screen.
- Pull the paddle backward and long pull for 5 seconds, the suspension will exit the lift mode and the height will rise to the high.

Caution

- The lift mode is an emergency usage scenario. Please drive safely after it is activated.
- After entering the lift mode, avoid intense driving. If there is an inevitable bumpy road and the suspension has a pulling vehicle body sound, it is a normal phenomenon.
- Before exiting the lift mode, please pay attention to the surrounding environment of the vehicle to avoid damage to the chassis caused by obstacles under the vehicle. If a serious collision occurs, please contact ROX Service Center in time.

Hint

- After the trailer mode is activated, the suspension height adjustment function is unavailable.
- If the road surface is uneven, it is a normal phenomenon that there is a height difference between the left and right sides of the vehicle after it enters the lift mode. After exiting the lift mode, the system will correct the deviation.

7 Driving

IV. Entering the basement

When the vehicle speed is less than 20km/h, click "Vehicle Settings → Vehicle → Mode" on the central control screen and then click "Enter Basement". The suspension height will be reduced to the height of Enter Basement mode, which is convenient for vehicles to enter and exit the basement.

After the Enter Basement mode is enabled, it will exit under the following circumstances:

- When the vehicle speed exceeds 50km/h, it will exit the Enter Basement mode and the height will be automatically adjusted to the lowest.
- When manually turning off the Enter Basement mode through the central control screen, the vehicle will exit the Enter Basement mode and automatically adjust the height to the low.
- According to Section 1 of Suspension Height, adjust the suspension height to exit the Enter Basement mode and adjust to the new target height based on the current mode.

V. Convenient boarding and alighting

Click on "Vehicle Settings → Vehicle → Mode" on the central control screen to turn on or off the "Convenient Boarding and Alighting" mode.

When the function is activated, the driver stops the vehicle, shifts the gear to P, and then activates the Convenient Boarding and Alighting function. The vehicle height will automatically lower to the Convenient Boarding and Alighting height. After the Convenient Boarding and Alighting function is enabled, it will exit under the following circumstances:

- When the vehicle speed exceeds 5km/h, the Convenient Boarding and Alighting function will be exited.
- Manually exit the Convenient Boarding and Alighting function through the central control screen.
- According to Section 1 of Suspension Height, adjust the suspension height to exit the Convenient Boarding and Alighting function and adjust to the new target height based on the current mode.

VI. Suspension maintenance mode

When the vehicle is stationary, click "Vehicle Settings → Vehicle → Mode" on the central control screen, then click and activate the "Suspension Maintenance Mode". The height adjustment function of the air suspension will be disabled.

After the maintenance mode is activated, it will exit and the height adjustment function will be restored under the following circumstances:

- When the vehicle speed exceeds 5km/h, the suspension will exit the maintenance mode.
- Manually turn off the "Suspension Maintenance Mode", and the suspension will exit the maintenance mode.

Caution

- Before inspecting the air suspension lift (including the scenario that the wheels are suspended), please activate the "Maintenance Mode" to ensure system safety.

XII. System fault

During the use of air suspension, if there is a system failure, the vehicle will prompt the driver in the form of text and icons on the instrument panel.

The fault prompt status is divided into three levels, with the increasing severity:

- Text hint.
- Yellow icon and text prompt.
- Red icon and text prompt.

Caution

- Drivers are requested to operate strictly in accordance with the text prompts to ensure safe use.

7.2.8 Speed-sensitive variable electronic power steering

Click "Vehicle Settings → Vehicle → Driving → Steering Power" through the central control screen, and click the "Steering Power" option to switch between the three steering modes of "Comfort, Standard, and Sport" (the default is comfort mode).

- Comfort: The steering wheel has lighter force, applicable to driving on congested roads or urban areas.
- Standard: Applicable to general driving.
- Sport: The steering wheel has heavier force, applicable to intense driving, high-speed, or rainy and snowy weather.

Warning

- Do not adjust the steering assist mode while driving, as it may distract the driver's attention from the road conditions and lead to an accident.

7 Driving

7.3 Driving essentials

7.3.1 Driving essentials for extended range vehicles

When the vehicle is in use, make sure to comply with the specified driving regulations to ensure safe driving.

I. Wet and slippery road surface

When driving on wet and slippery roads, be sure to reduce speed and drive with caution.

Emergency braking, sudden acceleration, or quick steering on wet and slippery roads can cause the tires to skid, making it difficult to control the vehicle and increase the risk of accidents.

II. Driving through water

1. When it is necessary to drive through water

- Before driving through water, please enable the wading mode in the ROX mode. Analyze the road conditions and confirm the depth of the water. The water depth must not exceed the lower edge of the vehicle body. When the water depth or road conditions are unknown, the vehicle must detour. It is forbidden to forcefully pass through.
- While driving through water, do not stop, and maintain a low speed (the speed must not exceed 10 km/h).
- When passing through intersections or intersecting with other vehicles, drive carefully to avoid splashing water over the front grille.

2. After driving through water

- Depress the brake pedal gently several times to clear residual water from the brake disc and ensure the braking system is working properly.
- Check the vehicle's horn, all lamps, etc.
- Please go to the ROX Service Center for a regular check-up as soon as possible, as water may enter the transmission system components and dilute the lubricant, potentially causing system failures during wading.

Warning

- Do not drive on a road section where the depth of stagnant water is unknown. This can avoid damaging electrical components or the range extender.
- Do not drive through water for extended periods to avoid damaging the vehicle.
- Do not drive on saltwater-filled sections to avoid corrosion of the vehicle body.
- After the vehicle has bottomed out or been submerged, go to the ROX Service Center for inspection to avoid personal injury or vehicle damage due to mechanical damage to the power battery or high-voltage safety incidents.

III. Off-road escape

There is a risk of vehicle damage during driving if:

- The vehicle becomes stuck, for example, on a high curb or unpaved road.
- Drive over obstacles, such as curb, speed bump, or pothole, at a high speed.
- A heavy object hits the underbody or chassis component.

In such cases, the body, underbody, chassis components, wheels, or tires may suffer from unseen damage. Components suffered such damage may malfunction unexpectedly or fail to withstand pressure as expected in an accident.

If the underbody guard is damaged, flammable materials such as leaves, grass, or twigs may accumulate between the underbody and the underbody guard. If these materials come into contact with the hot parts of the exhaust system, a fire may be caused.

In such cases, please go to the ROX Service Center for inspection and repair immediately. If you notice a decrease in driving safety while continuing your journey, please immediately pull over to a safe location and pay attention to the road and traffic conditions. In this case, please consult the ROX Service Center.

When driving off-road, sand, mud, and water or oil-water mixtures may enter the brake. This can result in weakened braking or complete failure of braking functions due to increased wear. The braking characteristics will vary depending on the material that gets trapped in the brake. After off-road driving, the brake should be cleaned. If you notice a reduction in braking effectiveness or hear a loud noise, please go to the Extreme Stone Automotive Service Center to check the braking system immediately. Adjust your driving style according to the different braking characteristics.

Off-road driving increases the likelihood of vehicle damage, which may lead to failures of assembly or system. Please go to the ROX Service Center to repair any damaged parts of the vehicle immediately. Adjust your driving style according to the terrain conditions. Please drive with caution.

IV. Safe braking

When the vehicle needs emergency braking, firmly press the brake pedal.

V. Long downhill

When driving on a long downhill, you can enable HDC in the ROX mode or set the regenerative braking to its maximum level. If you hold the brake pedal down for a long time, even with lamp pressure, it can cause the braking system to overheat, wear out, or even fail, potentially leading to an accident.

Do not rely on the vehicle's inertia to coast in N gear or when the powertrain is off, as this can result in a lack of braking and steering assistance, increasing the risk of an accident.

VI. Driving in rainy day

When driving in the rain, there will often be poor visibility, fogging on the windows, and slippery road. Please drive with caution.

Emergency braking, sudden acceleration, or quick steering on wet and slippery roads can cause the tires to skid, making it difficult to control the vehicle and increase the risk of accidents. When driving in a rainy

7 Driving

day, water film is easy to form between the tire and the road surface. At this time, the tire is easy to lose road adherence. Please drive at a reduced speed.

VII. Driving mileage

When you want to maximize your driving mileage, please keep the following points in mind:

- Energy recovery: Adjust the regenerative braking level to a higher setting to recover more electrical energy during coasting.
- Drive smoothly to avoid sudden acceleration and deceleration.
- Traffic Congestion: Try to avoid driving on congested roads. Stop-and-go driving can accelerate energy consumption.
- A/C: Use the A/C only when necessary. When using it, close the windows to reduce resistance. This helps reduce energy consumption and increase the range.
- Tire pressure: Ensure that tire pressure is within the normal range. Lower tire pressure increases rolling resistance, which will increase energy consumption.
- High-speed driving: Maintain a stable speed and try to apply the brakes gently in advance when needed, which maximizes energy recovery.
- Regular maintenance: Regular maintenance is essential to keep the vehicle in optimal condition. A dirty air filter, spark plugs, engine oil, etc., can reduce the performance of the range extender.

VIII. Avoid damage to vehicle components

Do not keep the steering wheel in the extreme position for a long time, as this may damage the steering motor.

When driving on a bumpy road, try to maintain a lower speed to avoid damaging the wheels or vehicle underbody.

Warning

- Do not drive over park near flammable materials. As the exhaust system and exhaust gases can be very hot, and any flammable materials in the vicinity could potentially cause a fire.

7.3.2 Winter driving essentials

Before driving your vehicle in winter, make the necessary preparations and inspections and drive your vehicle in a manner suitable for the main winter weather conditions.

I. Vehicle preparation in winter

- Use oil and fluid suitable for winter temperatures (engine oil, coolant, windshield washing fluid).
- When driving on icy or snowy roads, fit snow tires or install tire chains on the wheels.

II. Preparation before driving

- If the windows or windshield wipers are frozen, do not operate the windshield wipers. Apply warm water to melt the frozen part and wipe it clean immediately to avoid refreezing.
- Clean any ice or snow that may have accumulated on the windows, windshield, roof, and chassis of the vehicle.
- Remove any mud or snow from your shoes before entering the vehicle.

III. Driving on ice and snow road

- Maintain a safe distance from the vehicle ahead and adjust your speed appropriately for different road conditions to avoid sudden acceleration or deceleration.
- When turning, slow down in advance, turn the steering wheel gently, avoid sharply turning the steering wheel, and pass through at a steady speed.

IV. Parking

On ice and snow surfaces, try to park the vehicle on a flat road and engage the parking gear with the electronic handbrake activated. If necessary, place wheel stoppers.

V. Replacing winter tires

When driving on icy and snowy roads in winter, replace all four tires with winter tires simultaneously. The four tires must be of the same size, brand, construction and tread pattern.

VI. Snow chain

This vehicle is not equipped with snow chains. You may buy them yourself. When using snow chains, please note the following:

- Inappropriate snow chains can damage the vehicle's tires, wheels, and braking system. Please carefully check the specifications of the original tires and the relevant usage instructions of the snow chain manufacturer.
- The thickness of the snow chains should not exceed 7 mm.
- After installing snow chains, the speed should not exceed 50 km/h, or the lower speed limit allowed by the snow chain manufacturer.
- When driving on snow-free roads, please remove the snow chains to avoid excessive wear on the wheels or snow chains.

7 Driving

Warning

- Do not exceed the speed limit on the road or the speed limit specified for the winter tires used.
- Do not drive on bumpy or pothole roads.
- Do not use chains on snow-free roads.
- Do not use tires that do not match the specified specifications.
- Do not leave the tire pressure outside the recommended range.
- Do not exceed the speed limit specified for the snow chains used.
- Do not perform sudden acceleration, steering, braking or shifting operations.

7.3.3 Precautions for extended range vehicles

I. Precautions for power battery

If the power battery level is too low, the vehicle can only generate power through the range extender. At this time, its performance will be reduced. Therefore, it is necessary to reserve some energy to cope with more severe driving conditions (such as overtaking, intense driving, etc.).

II. Exhaust system

The vehicle's exhaust system can produce high temperatures. Do not remove the heat insulating plate in this area. When the range extender is activated, flammable materials such as leaves and dry grass should not come into direct contact with the high-temperature exhaust system, as this could ignite these items and cause a fire, leading to serious personal injury and vehicle damage.

III. Condensation during parking vehicle

When parking the vehicle after using the A/C, water marks on the vehicle's parking location are normal condensed water from the A/C.

IV. Driving in maximum speed

When driving downhill, the maximum speed may trigger an overspeed fault of the drive motor. This can cause irreversible damage to the drive motor. Please keep the speed within an appropriate range.

Warning

- Please drive at the speed limit specified by national road regulations. Failure to comply with traffic rules may result in serious traffic accidents or even casualties.

7.4 ROX mode

7.4.1 ROX mode

I. ROX Mode

The ROX mode includes seven modes: highway, AUTO, deep snow, mud, mountain road, sand and wading mode. To enter the ROX mode interface, click the “ROX Mode” icon at the bottom of the central control screen. Only one mode can be active at a time (enabling Mud Mode while Deep Snow Mode is active will automatically disable the latter).

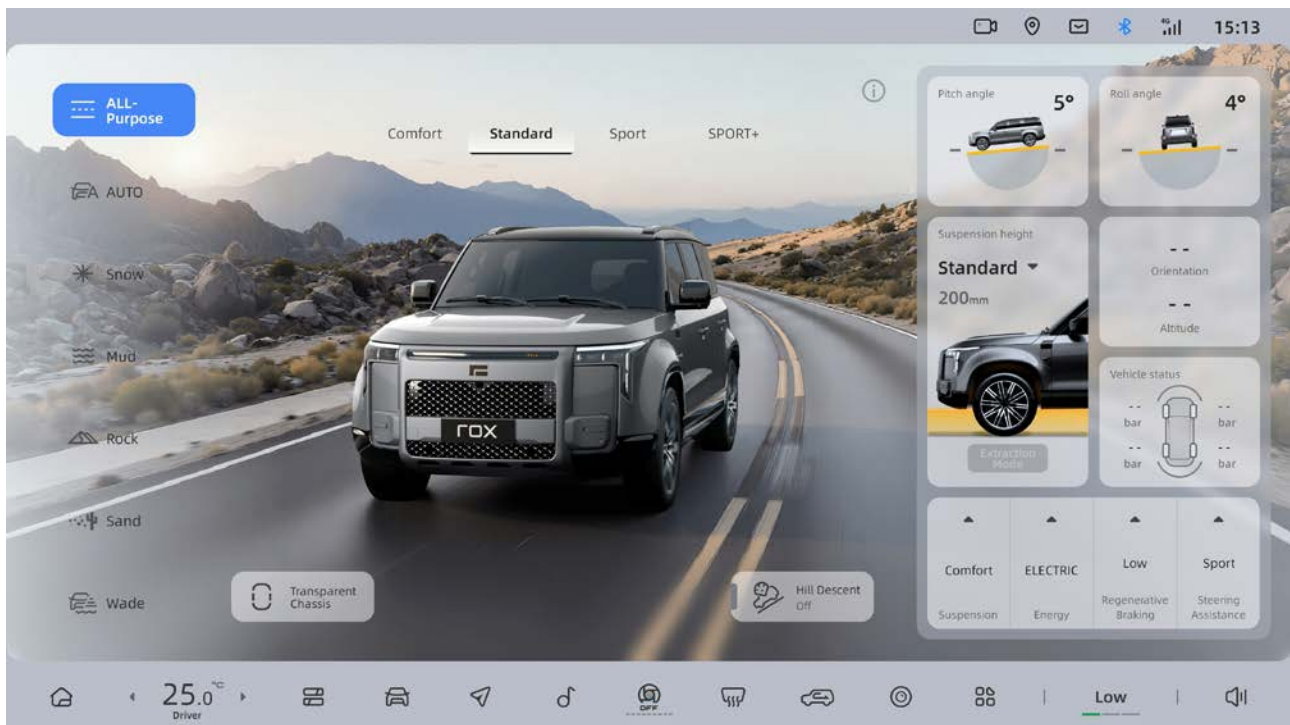

7 Driving

II. Paddle switch adjustment mode

By moving the lever forward or backward, you can switch from the current mode to the previous mode or next mode. The switching sequence is: Highway → Auto → Deep Snow → Muddy → Mountain → Sandy → Wading → Highway.

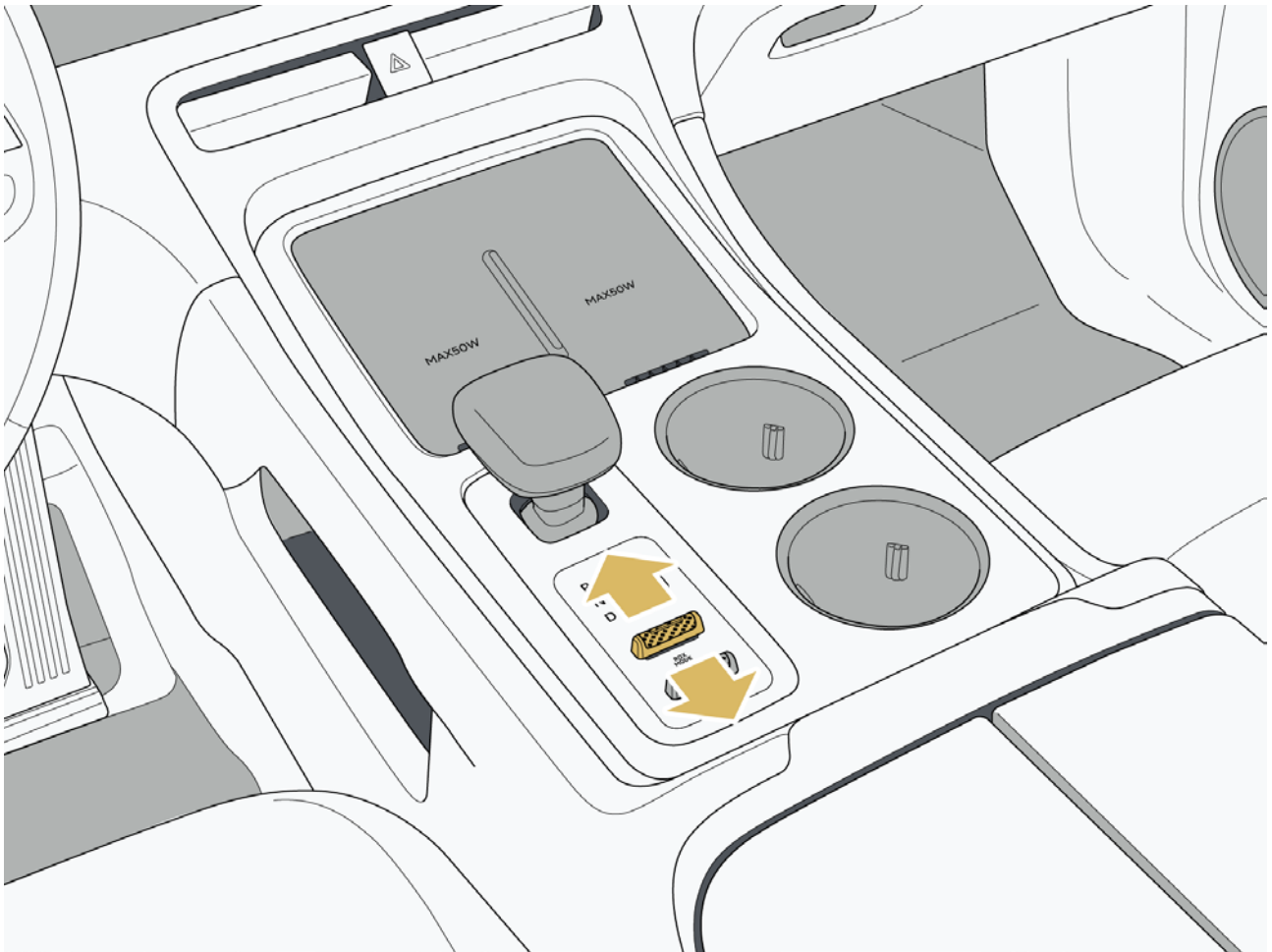

II. Mode introduction

Highway: Highway mode is primarily suitable for vehicles driving on paved surfaces such as cement and asphalt.

1. Entry and exit
 - Entry mode: Every time the vehicle is powered on, the default mode is road mode or the other mode exits and automatically enters the road mode.
 - Exit mode: When switching from highway mode to other mode, the highway mode will automatically exit. If the assisted parking is in operation, the mode cannot be switched.
2. Mode setting
 - After entering the highway mode, you can set the power mode (comfort/standard/sport/sport+), suspension mode (comfort/standard/sport/ROX/intelligent), power steering (comfort/standard/sport), energy recovery (low/medium/high/intelligent), and energy mode (electric priority/fuel priority/hybrid) in the mode interface.

Deep snow mode: The deep snow mode is mainly used for driving on snowy roads, uncompacted and loose snow surfaces, and other road conditions (highway mode is recommended for compacted snow surfaces and ice surfaces).

Warning

- When the snow drift mode is enabled, the vehicle will automatically turn off the ESP. It may cause a risk of instability. It is necessary to drive in a specific area.

Caution

- When running snow drift, the forward collision warning/lane departure assist/navigation assist/adaptive cruise control/LCC functions will not be activated. Please drive with caution.
- When the speed exceeds 75 km/h in snow drift mode, the vehicle stability system is activated, and the snow mode automatically exits.

Mud mode: The mud mode is primarily aimed at driving on roads with deeper, soft and, muddy conditions, or soft ruts.

Mountain road mode: The mountain road mode is primarily aimed at driving on roads with large boulders, rocky terrain, undulating mountain roads, and steep slopes.

Sand mode: The sand mode is primarily aimed at driving on roads where the wheels are prone to sinking, dry soft sand, sand dunes, deserts.

Wading mode: The wading mode is primarily aimed at driving on roads such as rivers, streams, riverbeds that may have pebbles, wet mud, and aquatic plants.

Caution

- When the body angle exceeds 15°, the rearview mirror is folded, the speed exceeds 15 km/h, or any front passenger door is open, the wading detection is suspended.

III. Off-road cruise

1. Off-road cruise: After entering the mode, click to enable "Off-Road Cruise". The system judges the current speed when entering:
 - When the speed is above 17 km/h, the off-road cruise function cannot be enabled.
 - When the speed is between 2 km/h and 17 km/h, the off-road cruise function is enabled. The current speed is set as the driving speed by default, with the off-road cruise icon illuminated on the instrument panel.

7 Driving

- When the speed is between 0 km/h and 2 km/h, the off-road cruise function is enabled. The current speed 2 km/h is set as the driving speed by default, with the off-road cruise icon illuminated on the instrument panel.
2. Adjustment of off-road cruise speed
 - Pull the right side of the steering wheel to the up position once to the first gear, and the current speed increases by 1 km/h. Pull the right side of the steering wheel to the up position once to the second gear, and the current speed increases by 5 km/h.
 - Pull the right side of the steering wheel to the down position once to the first gear, and the current speed decreases by 1 km/h. Pull the right side of the steering wheel to the down position once to the second gear, and the current speed decreases by 5 km/h.
 3. Page information and functions
 - Tire pressure: Display the tire pressure values of four wheels.
 - Pitch angle: For the current pitch angle of the vehicle, 0° is horizontal, the front of the vehicle is up by 1~90°, and the front of the vehicle is down by 1~90°.
 - Roll angle: For the current roll angle of the vehicle, 0° is horizontal, the vehicle tilts to the left by 1~90°, and the vehicle tilts to the right by 1~90°.
 - Output torque (front/rear): The percentage of torque the vehicle is able to output.
 - Compass: The direction the front of the vehicle is pointing to, which changes as the direction of the front of the vehicle. The compass shows eight directions: east/south/west/north/northeast/northwest/southeast/southwest.
 - Altitude: The altitude of the vehicle's current location (GPS point).
 4. Automatic exit from off-road cruise
 - When the electronic handbrake is activated, the off-road cruise mode automatically exits.
 - System is abnormal.
 - The driver leaves the driver's seat or the driver unbuckles the seat belt.
 - The gear is switched to a non-D gear.
 - The throttle opening exceeds the set value.
 - The vehicle speed is greater than or equal to 60 km/h.

7.5 Operation of light and wiper

7.5.1 Exterior light switch

I. Turn off external lamp

Click "Vehicle Settings → Vehicle → Lights" on the central control screen to set the vehicle lamps. Click the "Close" icon to turn off all external lamps.

II. Turn on the position lamp

Click the "Position Light" icon to turn on the position lamp. When the position lamp is turned on, the position lamp and license plate lamp will be on.

III. Turn on low beam lamp

Click the "low beam" icon to turn on the low beam, and the low beam indicator and position indicator on the instrument screen are lit.

IV. Turn on automatic mode

When the vehicle's power is in non- "OFF" mode, the external lamp automatic mode is turned on by default. You can also manually turn on the external lamp automatic mode by clicking the "Auto" icon. In the automatic mode, the low beam and position lamps are automatically controlled to turn on and off based on the lamp level of the environment.

Caution

- In low visibility conditions, it may affect the automatic mode. Please manually control the lamps according to the actual road conditions.

V. Adjust the low beam height

The vehicle is equipped with a low beam lamp height adjustment function. When the low beam lamps are on, the driver adjusts the low beam lamp height according to the correct driving posture.

VI. Welcome lamp

Click the "Approach Welcome" switch to turn on the welcome function. When you approach/leave the vehicle, the welcome lamp on the door handle will automatically light up/off.

VII. Follow me home

Click "Close, 15 Seconds, 30 Seconds, 60 Seconds" below "Follow Me Home" and select the desired option. After enabling the Follow Me Home function, and locking the vehicle, the low beam lights and position lights can be delayed according to the settings.

Hint

- When the vehicle's rain-twilight sensor detects that it is daytime, the Follow Me Home function will not be activated.

7 Driving

7.5.2 Low beam height adjustment

The vehicle is equipped with a low-beam headlamp height adjustment function. When adjusting the low-beam headlamp, the vehicles power is in non- "OFF" mode. Click "Vehicle Settings → Vehicle → Lights → Low Beam Light Height" option on the central control screen to select from low/medium/high gears. The driver can adjust the lights to the best position according to the correct driving habits.

7.5.3 Automatic high beam light

I. Automatic high beam

When the vehicles power is in the "READY" mode, the low beam lights are on and the light gear is in "AUTO" , the low beam lights will automatically switch to high beam when the lights of oncoming vehicles, the tail lights of preceding vehicles, or other light sources are not continuously detected. To turn off the high beam lights, you can switch the light gear to non- "AUTO" , or when the vehicles power is not in the "READY" mode, and the high beam lights will turn off. The automatic high beam is turned on by default. You can turn off the automatic high beam function by clicking "Vehicle Settings → Vehicle → Lights → Automatic High Beam" through the central control screen.

II. Overtaking light

Turn the left side control lever on the steering wheel twice to alert the vehicle ahead to yield.

7.5.4 Automatic low beam light

When the vehicles power is in non- "OFF" mode and the light gear is in "Auto" , the vehicle will automatically turn on or off the low beam lights and position lights based on the current brightness (such as in a dimly lit underground parking garage). The low beam lights and position lights can be manually turned off through the central control screen.

Hint

- To prevent the driver from forgetting to turn on the headlamps when driving at night, when the vehicle power switches from "OFF" to "ON" mode, the vehicle will automatically switch the light level to Auto mode.

7.5.5 Brake lamp

The brake lights turn on when the brake pedal is depressed and turn off when released; when the vehicle control system intervenes in the vehicle's braking, the brake lights will also turn on.

When the vehicle triggers an emergency brake, the hazard warning lights flash while the brake lights turn on. When the vehicle speed drops to a certain value, the hazard warning lights stop flashing and the brake lights turn off.

7.5.6 Reverse lamp

When the gear is shifted to R, the reverse lights turn on. When the gear is shifted out of R, the reverse lights turn off.

7.5.7 Fog light switch

Click the "rear fog light" icon through the central control screen. After clicking the icon to turn on the rear fog light, the instrument screen will display the rear fog light icon, and click again to turn off the rear fog light.

Hint

- When using the rear fog lights, you need to turn on the low beam lights first.
- When the vehicle detects smog, it will automatically turn on the rear fog lights. You can manually turn off the rear fog lights.

7.5.8 Windshield wiper and washer

I. Windshield wiper control lever

S/N	Name
1	Close
2	Automatic low speed sensitive gear
3	Automatic high speed sensitive gear
4	Manual low speed gear
5	Manual high speed gear

7 Driving

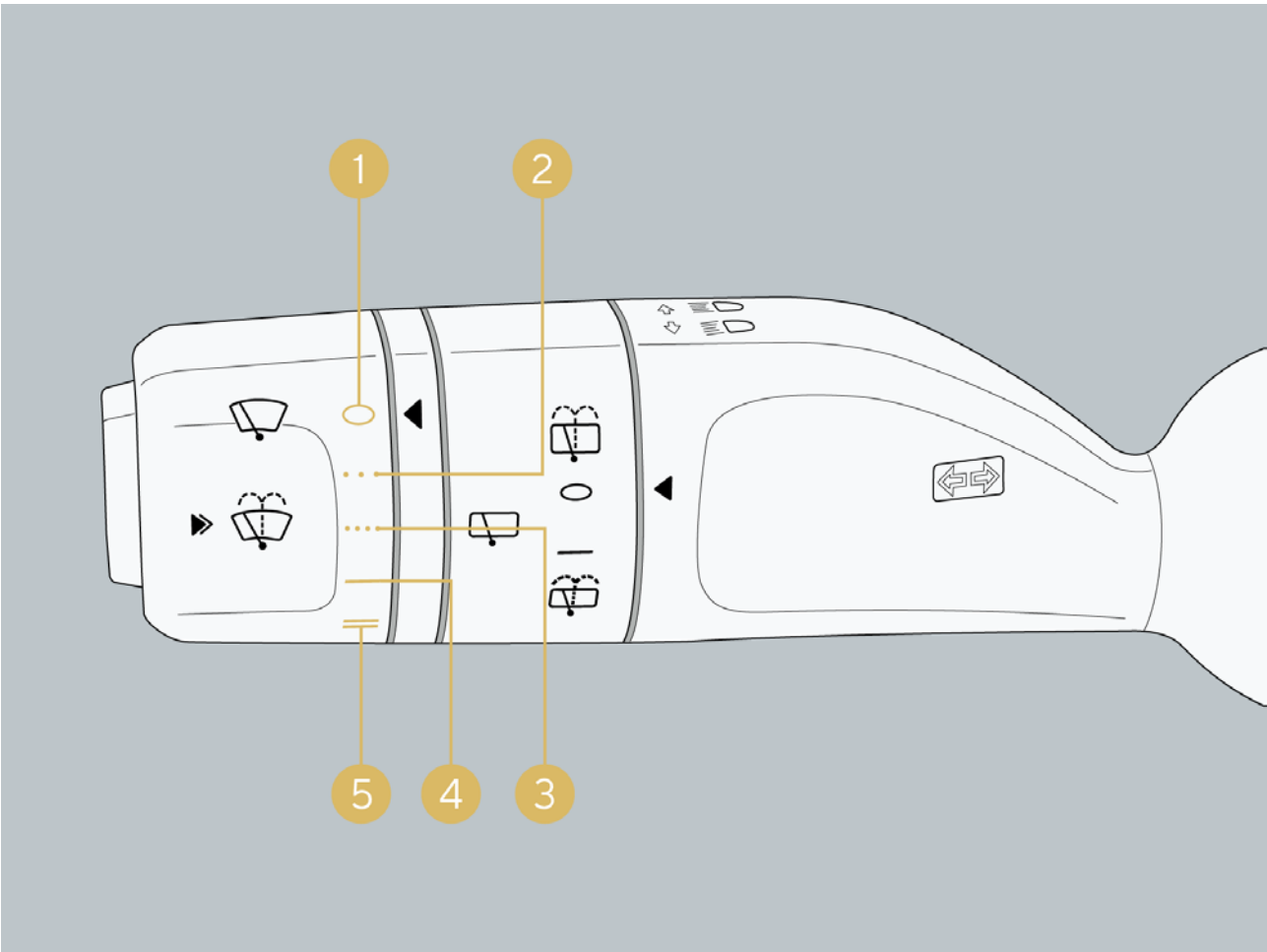

II. Manual wiper

Gently press the wiper wash button, and the wiper will automatically sweep once. Press again to activate the wash function, and the wiper will automatically sweep once.

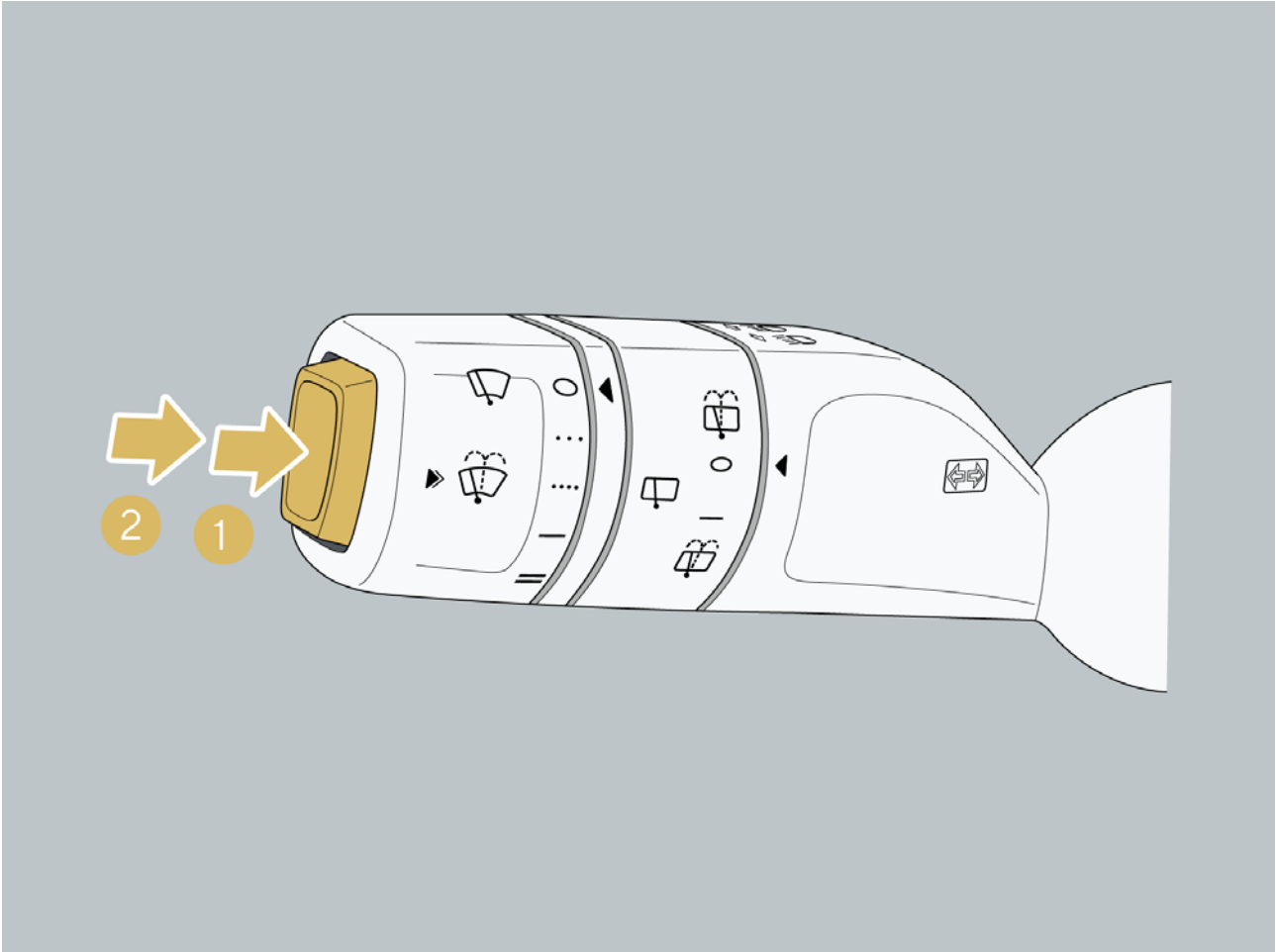

III. Automatic wiper

After the vehicle starts, if the wiper control lever is in the automatic low speed sensitive mode or the automatic high speed sensitive mode, the sensor will automatically adjust the sweeping frequency based on the amount of rain. The automatic high speed sensitive mode sweeps faster and more frequently than the automatic low speed sensitive mode.

Warning

- Before turning on the windshield wiper, please thoroughly clean the snow and ice on the windshield.
- Avoid turning on the wiper when the windshield is dry or there is no washer fluid in the wash pot, as this may damage the wiper blade or the windshield.

7 Driving

Caution

- When the ambient temperature is below 0°C, the vehicle starts, and the wiper is in automatic mode, the wiper enters a protective mode. It exits the protective mode when the vehicle speed is greater than 5 km/h.

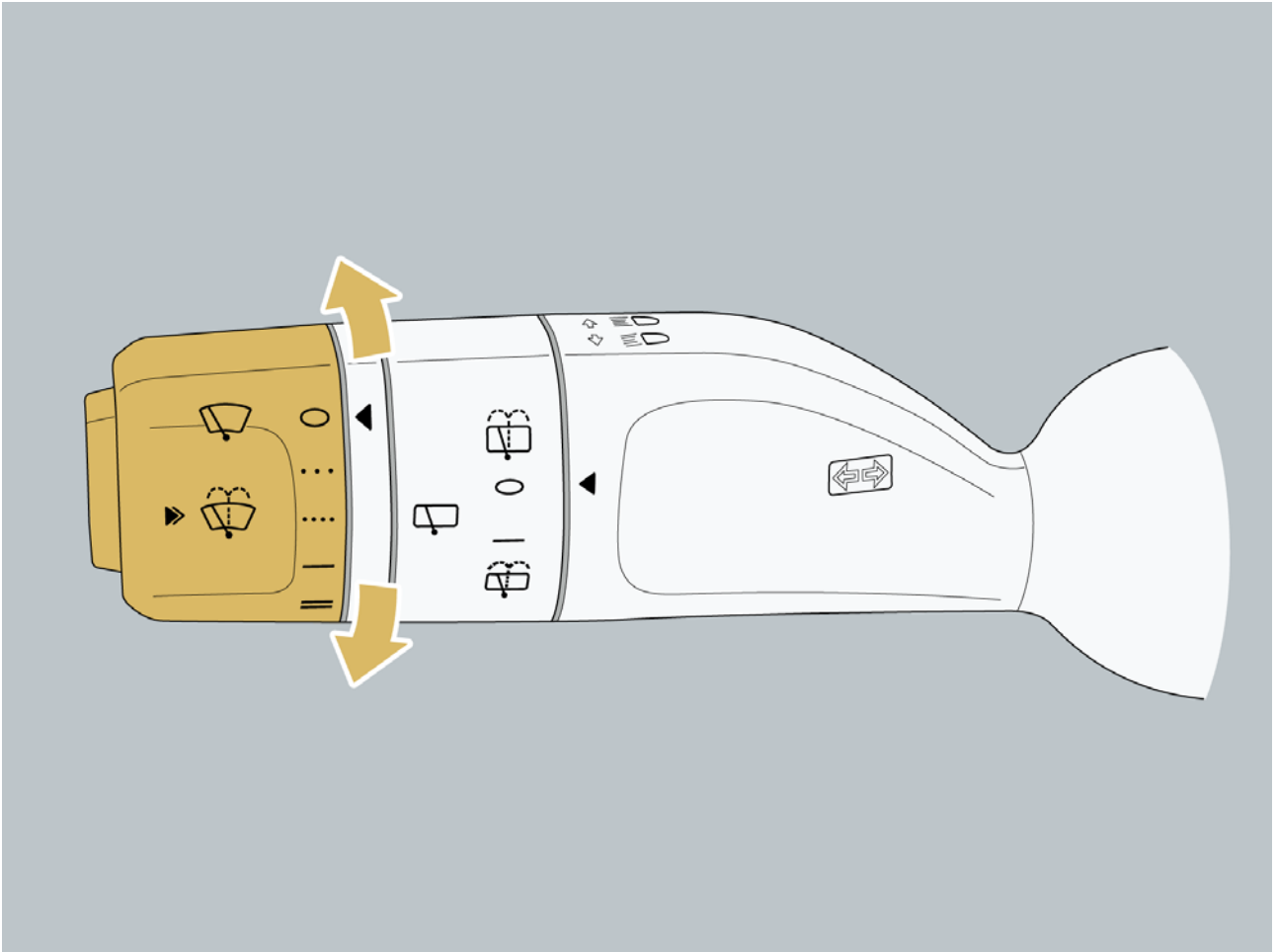

7.5.9 Rear window wiper and washer

I. Rear wiper control lever

S/N	Name
1	Turn off rear window wiper
2	Turn on rear window wiper

After the vehicle is started, turn the rear window wiper switch to turn on/off the rear window wiper. Turn the rear window wiper switch forward to activate the rear window glass washing function. When the windshield wiper is turned on, the vehicle enters R gear. If the rear wiper is not turned on manually, the rear wiper will automatically sweep.

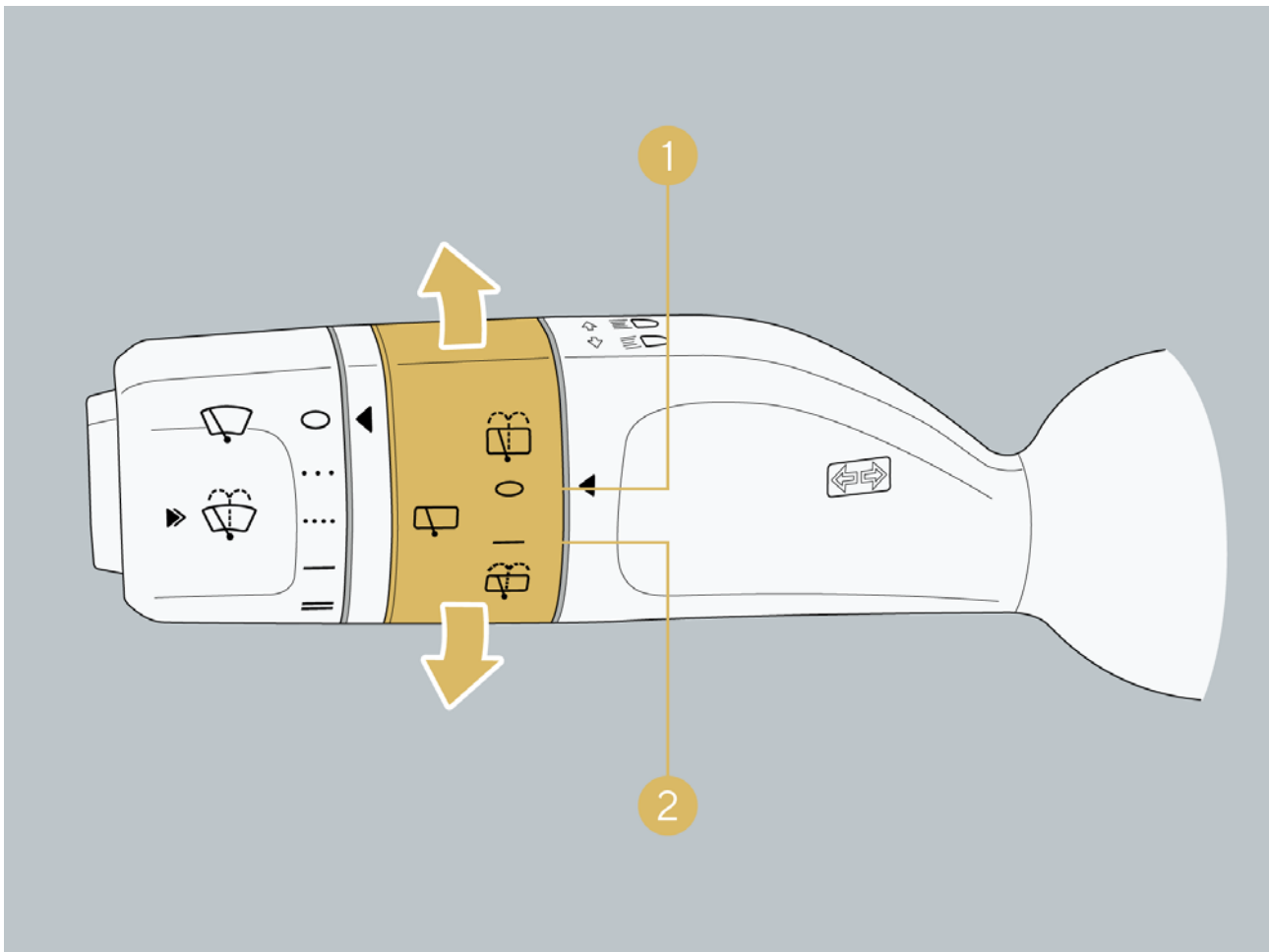

7 Driving

7.6 Combined driving assist system

7.6.1 ACC

Adaptive Cruise Control (ACC) senses the speed of the vehicle ahead through the forward sensors, controls the vehicle to follow the vehicle ahead at a set speed and time limit, and automatically adjusting the speed by accelerating or decelerating. When ACC is activated, it can follow the vehicle ahead until the vehicle stops. If the vehicle ahead leaves in a short time, it can automatically start to follow. If the vehicle ahead parks for too long, the electronic handbrake will automatically engage, and the function will exit.

ACC is mainly suitable for dry and smooth standardized long straight roads, such as highways, urban expressways, highways, long straight trunk roads, etc.

I. Adaptive cruise activation

When ACC meets the following conditions, a gray icon indicating that ACC can be activated appears on the instrument panel. By pulling the right side lever on the steering wheel inward, you can activate ACC function:

- The front view camera and millimeter-wave radar functions are normal, with clear vision.
- The ACC is fault-free.
- The driver's seat belt is fastened.
- All doors are closed.
- The vehicle is in D gear.
- The driver does not depress the brake pedal.
- The speed does not exceed 130 km/h.
- ABS, TCS, electronic parking brake, HHC, or VSC are not triggered.

After activating ACC, when there is no vehicle ahead, the ACC applicable speed range is 30~130 km/h. When there is a vehicle ahead, the ACC applicable speed range is 0~130 km/h. When the vehicle speed is below 30 km/h and the function is activated, set 30 km/h as the cruise speed. When the vehicle speed is above 30 km/h and the function is activated, set the current speed as the cruise speed.

Caution

- When the LCC function and the navigation assist function are activated, the adaptive cruise control function as a sub-function will be activated simultaneously. If the adaptive cruise control function exits due to not meeting the working conditions, the LCC function and the navigation assist function will also exit.

Hint

- When applying the ACC, you can deeply depress the accelerator pedal to operate the vehicle in a short time. At this point, the ACC will no longer follow the vehicle ahead. When you release the accelerator pedal, the system will control the vehicle to return to the cruise speed.
- When ACC exits, a gray icon that can activate the ACC reappears on the instrument screen. The last activated auxiliary function and the following distance can be restored by turning up the right lever on the steering wheel.

7 Driving

II. Adaptive cruise operation

Activate, set, and exit operations of adaptive cruise by pulling the right lever of the steering wheel:

- Pull inward once to activate the adaptive cruise function.
- Pull outward once to exit the adaptive cruise function.
- Pull up once to increase cruising speed or restore the last activation function.
- Pull down once to reduce the cruising speed.

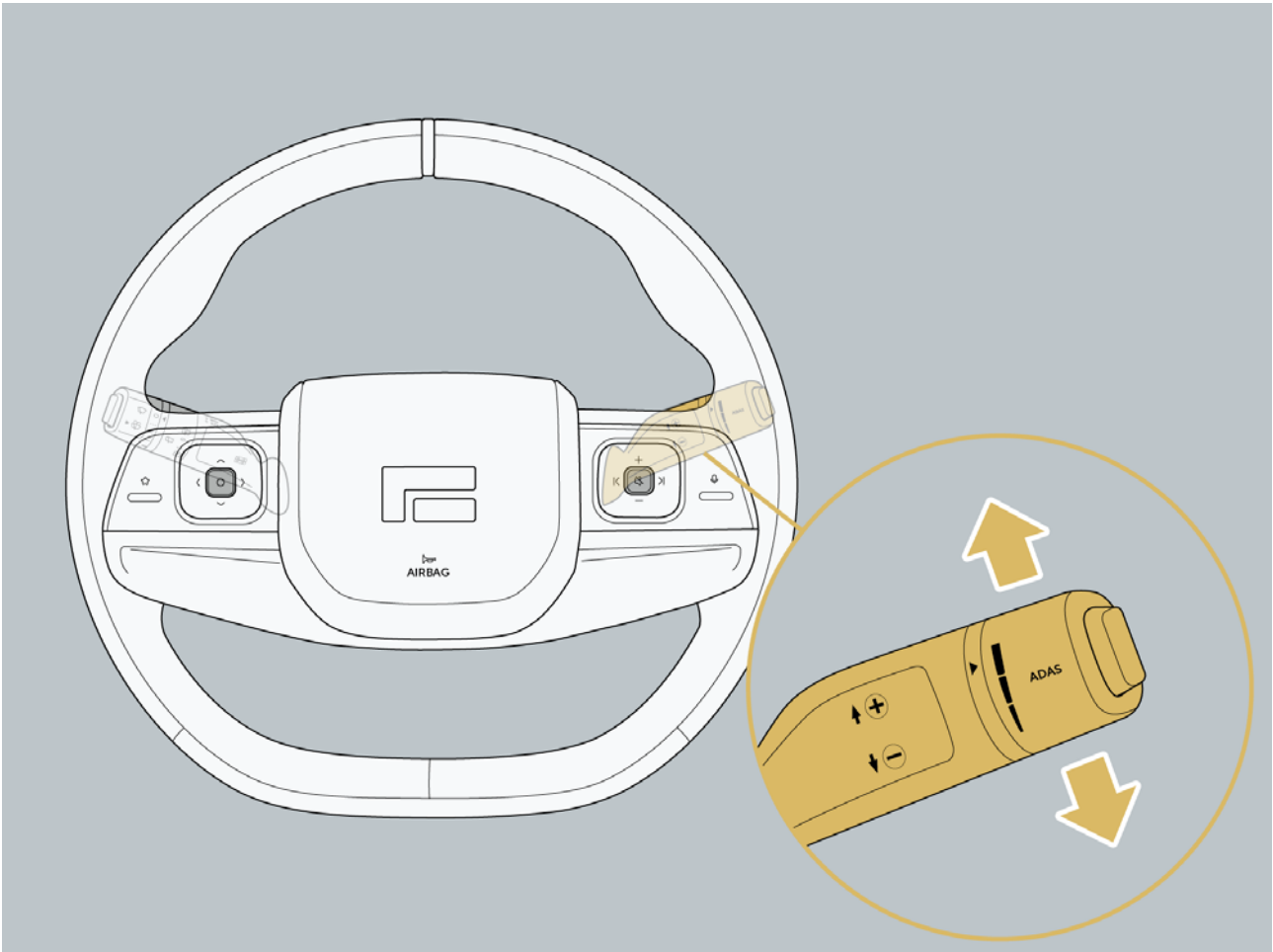

- Turn outward to reduce the follow-up time headway.
- Turn inward to increase the follow-up time headway.

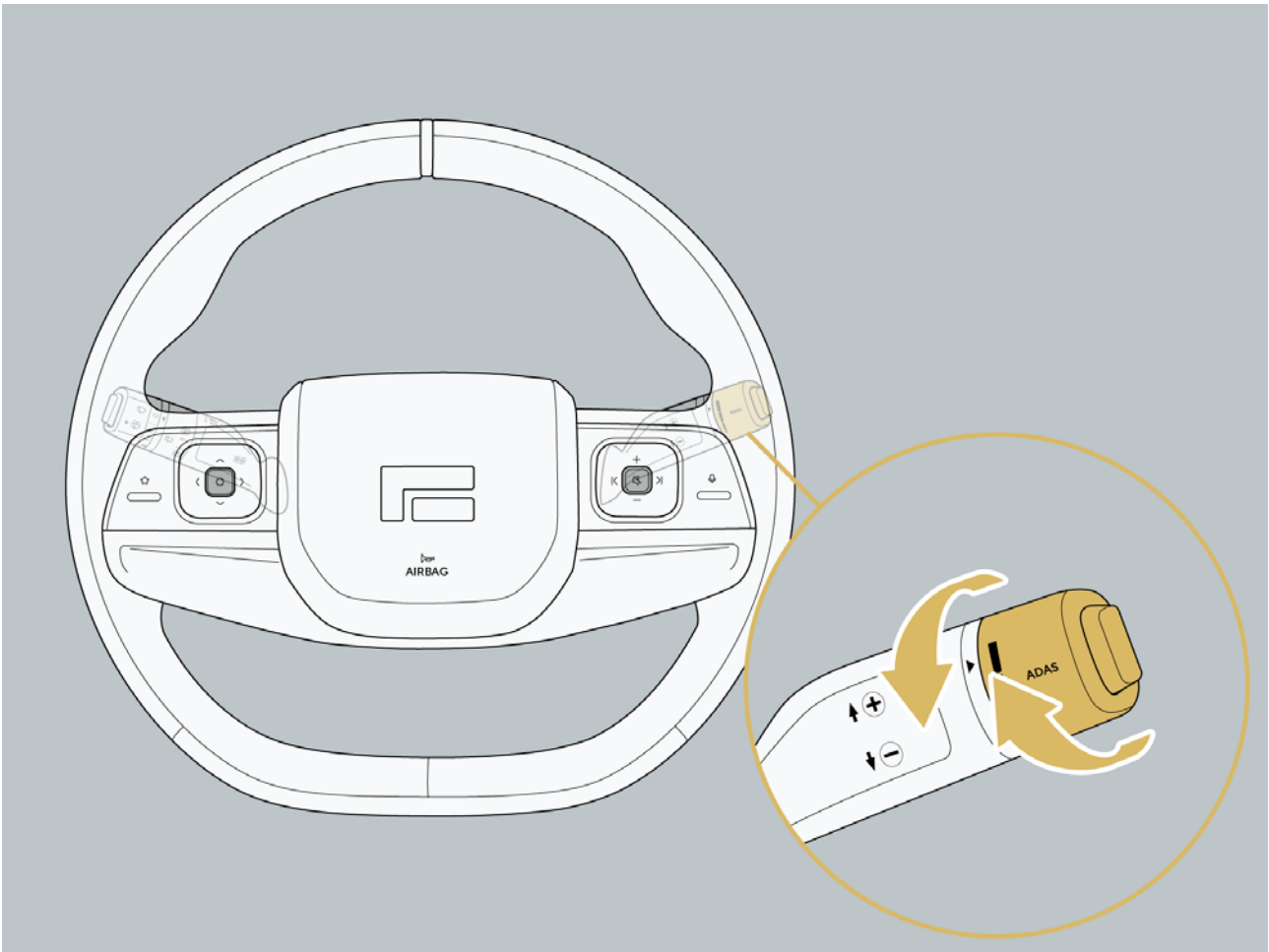

III. Following and starting

Following: In the following cruise state, the vehicle automatically adjusts its speed and distance based on the speed of the vehicle in front. If the vehicle in front slows down and stops, the vehicle will also brake automatically until it stops.

Starting: If the following vehicle in front starts within 1 min, the vehicle will automatically follow. If the following vehicle in front starts between 1 and 5 min, the vehicle will prompt the driver to lightly depress the accelerator pedal to confirm following. If the following vehicle in front starts after more than 5 min, the vehicle will engage the electronic parking brake and exit the ACC.

Warning

- In some cases, the ACC may not detect traffic participants around the vehicle, or the perception is ineffective or untimely due to interference factors. Therefore, when the vehicle follows and starts, you need to always pay attention to the traffic conditions and the surrounding road environment to avoid collisions.

7 Driving

IV. Adjustment of cruise speed

After activating ACC:

- Push the lever on the right side of the steering wheel up to the first gear to increase the cruise speed by 1 km/h.
- Push the lever on the right side of the steering wheel up to the second gear to increase the cruise speed by the nearest multiple of 5 km/h. For example, if the current cruise speed is set at 57 km/h, pushing up to the second gear will display 60 km/h. When pushing and holding the second gear for a long time, the cruise speed will increase by multiples of 5 km/h.
- Push the lever down to the first gear to decrease the cruise speed by 1 km/h.
- Push the lever on the right side of the steering wheel down to the second gear to decrease the cruise speed by the nearest multiple of 5 km/h. For example, if the current cruise speed is set at 57 km/h, pushing down to the second gear will display 55 km/h. When pushing and holding the second gear for a long time, the cruise speed will decrease by multiples of 5 km/h.

The maximum set speed for ACC is 130 km/h. The minimum set speed is 30 km/h.

Warning

- When using ACC, please strictly adhere to road traffic safety regulations.

V. Adjustment of follow-up time headway

There are three gears for adjusting the follow-up time headway, which can be adjusted using the knob switch on the right side of the steering wheel:

- Rotate outward to reduce the time headway, with each click reducing one gear.
- Rotate inward to increase the time headway, with each click increasing one gear.

VI. Exit adaptive cruise

The adaptive cruise control function will exit the activated state when the following situations occur:

- Pull the gear lever on the right side of the steering wheel outward once;
- Depress the brake pedal;
- Follow the vehicle for more than 5 min.

Hint

- After the ACC exits, the vehicle may slow down due to kinetic energy recovery braking and no longer maintain a set distance from the vehicle in front.

VII. Function limitation

In the following scenarios, ACC function may have limited performance or may not be available:

- In a curve with a large curvature.
- On steep slopes, use ACC with caution on steep roads, as there is a risk of the vehicle rolling back when following-up and starting.

Camera perception-restricted scenarios, including but not limited to:

- Dim lighting conditions causing a decrease in recognition capabilities, such as at night, in the shade, during twilight, in tunnels, or in areas where shadows are cast on the road.
- Obstructed or dirty cameras, or camera installation position changed or loose, resulting in angle deviation.
- Strong light, backlight, reflection and abrupt changes in brightness, such as direct sunlight during the day, especially in summer, flashlights in the surrounding environment, road surface water reflection, entering or exiting tunnels.
-
- Extreme weather conditions such as high temperature, severe cold, causing the camera's performance to decline.
- Dust, water vapor, water droplets, dirt, or ice on the windshield in front of the camera, obstructing the camera's field of view.
- Severe weather conditions, such as rain, snow, fog, smog, sandstorms, etc.

Millimeter-wave radar perception-restricted scenarios, including but not limited to the following situations:

- The millimeter-wave radar position changed or loose, resulting in angle deviation.
- The radar being obstructed by mud, ice, metal objects, etc.
- Extreme weather conditions such as high temperature, severe cold, causing the radar's perception capabilities to decline.
- Vehicle collisions causing the radar's installation position area to be hit or the vehicle surface to be deformed.
- Electromagnetic field interference in the surrounding environment, such as heavy fog, rain, snow, or sandstorms.
- Due to the limitation of the characteristics of radar electromagnetic waves, there may be misidentification in some special scenarios, such as metal guardrail, green belt, cement wall, construction area, etc.

Only standard vehicle targets will be recognized and responded to. The following target scenarios cannot be recognized, including but not limited to:

- Horizontal vehicle target.
- Pedestrians or two-wheeled, three-wheeled, and other motorized vehicles.

7 Driving

- Road obstacles, such as water horses, crash cushions, cones, posts, triangular warning signs, etc.
- Vehicles driving across or in the opposite direction.
- Non-vehicle targets such as fences, traffic lights, road signs, barrier poles, walls, animals, etc.
- Special vehicle targets such as construction vehicles, engineering vehicles, heterogeneous vehicles, etc.

In the following scenarios, if the relative speed to the vehicle in front is too high, the ACC may not brake and decelerate in time:

- The vehicle ahead is stationary or moving slowly, especially at night or during uphill or downhill driving, where recognition may be delayed.
- The vehicle ahead suddenly brakes.
- A vehicle in an adjacent lane cuts into the path ahead of your vehicle.
- Your vehicle suddenly cuts into the path behind the vehicle in front.

Warning

- The ACC is a longitudinal comfort driving assist function. In any situation, you need to continuously monitor the road conditions and maintain active control of the vehicle.
- The adaptive cruise control function cannot guarantee accurate identification of the target or obstacle ahead in all scenarios. If the vehicle or obstacle target ahead only partially overlaps with your vehicle or partially cuts into your vehicle's driving track, the adaptive cruise control function may not recognize it and slow down to maintain a safe distance. At this time, you need to take over promptly. Please pay attention to the road conditions in real time and be ready to take over the vehicle at any time.
- It is not recommended to use ACC function in adverse weather conditions such as rain, snow, fog, smog, sandstorms, road puddles, icy roads, etc.
- The ACC is suitable for use on highways, national roads, main roads and other straight roads. It is not recommended to use ACC on muddy, narrow, non-standardized roads, uphill and downhill roads, sharp turns, crowded and crossroads with complex traffic conditions.
- It is not recommended to use ACC in complex traffic scenarios such as busy city areas, pedestrian or bicycle-heavy roads, intersections and congested sections.
- The above warnings and limitations do not cover all possible situations that may affect ACC. During use, various factors may interfere with the operation of the ACC system. To avoid safety incidents, please stay focused and always pay attention to the traffic environment, road conditions and vehicle status.

7.6.2 Cruise control

The cruise control (CC) automatically accelerates and decelerates through the driver's set speed. The cruise control is mainly suitable for dry and smooth standardized long straight roads, such as highways, urban expressways, expressways, long straight trunk roads, etc.

I. Activate cruise control

When the working conditions of cruise control are met (a gray icon indicating that cruise control can be activated appears on the instrument panel), the driver can activate the cruise control function by pulling the lever inwards once:

- The cruise control system has no faults.
- The driver is seated and fastened the seat belt.
- The driver needs to hold the steering wheel and watch ahead.
- All doors are closed.
- The vehicle is in D gear.
- The driver does not depress the brake pedal.
- ABS, TCS, electronic parking brake, HHC, or VSC are not triggered.
- The speed does not exceed 170 km/h.
- The vehicle is driving on a straight road.

When the vehicle's battery level exceeds 20%, the applicable speed for cruise control is 30 to 170km/h.

When the vehicle's battery level is greater than 10% but less than 20%, the applicable speed for cruise control is 30 to 150km/h. If the current set cruise speed is higher than 150km/h, the set cruise speed cannot be further increased.

When the vehicle's battery level is less than 10%, the applicable speed for cruise control is 30 to 150km/h. After applying the cruise control, you can take over the vehicle for overtaking in a short time by deeply depressing the accelerator pedal. At this point, the cruise control will no longer respond to the target vehicle speed. When you release the accelerator pedal, the system will control the vehicle to return to the cruise control.

Caution

- The cruise control function does not have an adaptive following function. It can only cruise control at the set speed. Please pay attention to the safety of the surrounding environment.

7 Driving

II. Cruise control operation

After activating the cruise control, the activation, deactivation and setting operations of the cruise control function can be achieved through the right lever.

- Pull inward once to activate the cruise control function.
- Pull up to increase cruising speed.
- Pull down to reduce the cruising speed.
- Pull outward once to exit the cruise control function.

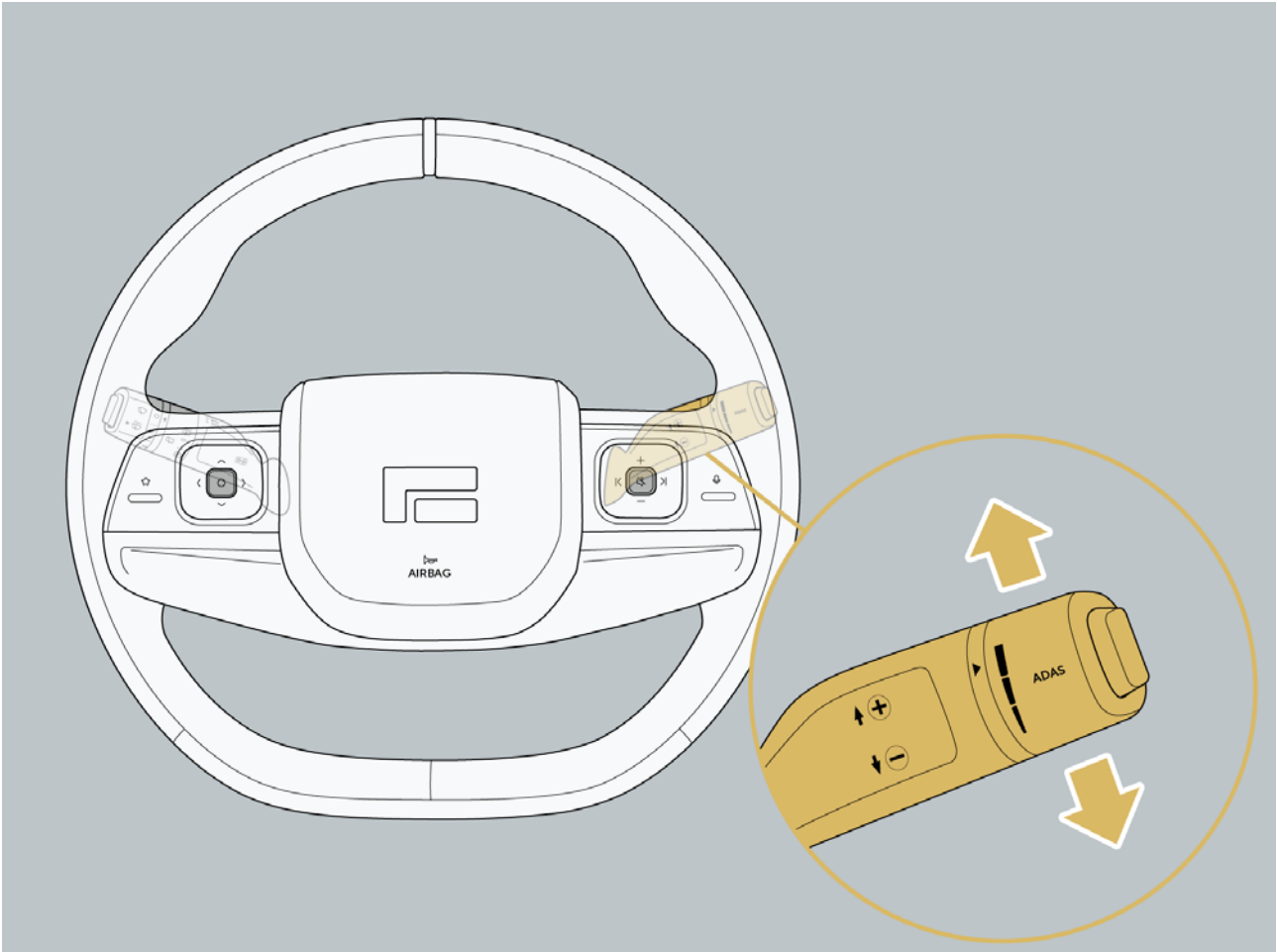

III. After activating the cruise control by adjusting cruise speed

- Push the lever on the right side of the steering wheel up to the first gear to increase the cruise speed by 1 km/h.
- Push the lever up to the second gear to increase the cruise speed by the nearest multiple of 5 km/h. For example, if the current cruise speed is set at 57 km/h, pushing up to the second gear will display 60 km/h. When pushing and holding the second gear for a long time, the cruise speed will increase by multiples of 5 km/h.
- Push the lever down to the first gear to decrease the cruise speed by 1 km/h.
- Push the lever down to the second gear to decrease the cruise speed by the nearest multiple of 5 km/h. For example, if the current cruise speed is set at 57 km/h, pushing down to the second gear

will display 55 km/h. When pushing and holding the second gear for a long time, the cruise speed will decrease by multiples of 5 km/h.

IV. Exit cruise control

The cruise control function will be deactivated when the following situations occur:

- Pull the gear lever on the right side of the steering wheel outward once.
- Depress the brake pedal.

In addition, when the cruise control does not meet the working conditions, the system will exit automatically. You should take over the vehicle immediately after the cruise control function exits.

Hint

- After the cruise control function exits, the vehicle may slow down due to kinetic energy recovery braking.

Warning

- The cruise control may unexpectedly exit due to unforeseen circumstances. Please always pay attention to the traffic conditions and road environment, and be ready to take over the vehicle at any time.

V. Functional limitation

In the following scenarios, the cruise control function may have limited performance or may not be available:

- In a curve with a large curvature.
- On roads with steep slopes, please use the cruise control with caution, as there is a risk of the vehicle sliding.

Warning

- The cruise control function is a longitudinal comfort driving assist function. In any situation, you need to continuously monitor the road conditions and maintain active control of the vehicle.
- It is not recommended to use cruise control function in adverse weather conditions such as rain, snow, fog, smog, sandstorms, road puddles, icy roads, etc.
- The cruise control function is suitable for use on highways, national roads, main roads and other straight roads. It is not recommended to use cruise control function on muddy, narrow, non-standardized roads, uphill and downhill roads, sharp turns, crowded and crossroads with complex traffic conditions.

7 Driving

- It is not recommended to use cruise control function in complex traffic scenarios such as busy city areas, pedestrian or bicycle-heavy roads, intersections and congested sections.
- The above warnings and limitations do not cover all possible situations that may affect cruise control function. During use, various factors may interfere with the operation of the system. To avoid safety incidents, please stay focused and always pay attention to the traffic environment, road conditions and vehicle status.

7.6.3 Lane departure assist

After the lane departure assist function is activated, it collects lane line information through the front view camera and, under certain conditions, applies steering torque in real-time to assist the driver in correcting the driving trajectory, keeping the vehicle centered in the current lane.

I. Setting

Click “Vehicle Settings → Assisted Driving → Driving Assist → LDA” through the central control screen to set the activation and deactivation of the LKA.

- Select “Not Enable” to turn off LKA.
- Select “Warning” to only send warning information and cannot correct the vehicle back into the lane.
- Select “Correction” , when the vehicle deviates from the lane, the system will control the vehicle’s lateral displacement, and pull the vehicle back into the original lane.

II . Function activation and exit

The lane departure assist function will be activated when the following conditions are met:

- The vehicle speed is between 60km/h and 130km/h.
- The function is enabled.
- The turn signal light is not turned on.
- The vehicle crossed the lane line.

When the function is activated, a text pop-up and an audible alarm will be sent, and horizontal auxiliary measures will be taken simultaneously.

The lane departure assist function will be exited if any of the following conditions are met:

- Turn the steering wheel to control the vehicle.
- The accelerator pedal is depressed.
- Depress the brake pedal.
- The turn signal light is turned on.
- The driver is hand-off for a long time.

During the activation of the function, the driver should hold the steering wheel in a normal grip. Otherwise, the alarm reminder may be triggered due to contact area or not holding the steering wheel.

III. Function limitation

Vehicles are traveling on sharp turns, roads with many road joints, and sections with special lane markings (such as deceleration warning lines, diversion lines, variable guidance lane lines, etc.).

Vehicles are traveling on roads without lane lines, with unclear lane lines or unclear road divisions, such as non-standardized roads, intersections, construction areas, intersections where lane lines converge or separate, etc.

The camera’s imaging capabilities may be affected, including but not limited to the following:

- Poor visibility due to nighttime.

7 Driving

- Poor visibility due to severe weather conditions (e.g., heavy rain, heavy snow, dense fog, sandstorms, etc.).
- Strong light, backlight, water reflection and extreme light contrast.
- The camera is obstructed by mud, ice, snow, etc.
- Extreme weather conditions such as high temperature, severe cold, causing the camera's performance to decline.

Warning

- The LDA is a driving assist function and cannot cope with all traffic, weather and road conditions. The driver should still pay attention to the vehicle ahead in real time, maintain an appropriate distance, control the speed, brake in time, hold the steering wheel, and be prepared to take over the vehicle at any time.
- Do not use LKA at road intersections, merging points, etc.
- The LDA is only a driving assist function, and the driver should maintain a grip on the steering wheel throughout the entire process.
- Do not use LKA on roads other than main roads or highways.
- If the vehicle's following distance is too close, the system may not be able to detect the lane lines and may not operate normally.
- When there are no lane lines on the road, there are multiple lane lines, lines are worn, blurred, or covered by other objects, and the system may not work properly.

7.6.4 LCC

Lane centering control (LCC) adds a lateral keeping control function within the lane based on the longitudinal control of adaptive cruise control. LCC detects the vehicle and lane line ahead through a forward sensor, controls the vehicle speed and maintains the following distance according to the longitudinal strategy of ACC. At the same time, when the lane lines on both sides are clear, LCC controls the steering to keep the vehicle driving within the lane.

Lane centering control (LCC) is mainly suitable for dry and smooth standardized long straight roads with clear lane lines, such as highways, urban expressways, expressways, long straight trunk roads, etc.

The lane centering control (LCC) is only a driving assist function and is not autonomous driving. During use, the driver should hold the steering wheel and pay attention to the road ahead, ready to take over the vehicle at any time.

I. Enabling/disabling LCC

Click “Vehicle Settings → Assisted Driving → Driving Assist → LCC” option through the central control screen to set the activation and deactivation of the LCC.

II. Activating LCC

When LCC meets the following safe driving conditions, a gray icon indicating that LCC can be activated appears on the instrument panel. By inwardly pulling the right side lever on the steering wheel twice, you can activate the LCC function:

- The front view camera and millimeter-wave radar functions are normal, with clear vision.
- The LCC system is fault-free.
- The driver’s seat belt is fastened.
- The driver needs to hold the steering wheel.
- All doors are closed.
- The vehicle is in D gear.
- The driver does not depress the brake pedal.
- The speed does not exceed 130 km/h.
- ABS, TCS, electronic parking brake, HHC, or VSC are not triggered.
- The vehicle is driving on a straight road.
- The vehicle is driving in the center area of the lane, and there are clear lane lines on both sides.

After activating LCC, when there is no preceding vehicle, the LCC applicable speed range is 30~130 km/h.

When there is a preceding vehicle, the LCC applicable speed range is 0~130 km/h. When the vehicle speed is below 30 km/h and the function is activated, set 30 km/h as the cruise speed. When the vehicle speed is above 30 km/h and the function is activated, set the current speed as the cruise speed.

7 Driving

Caution

- When the navigation assist function is activated, the LCC function as a sub-function will be activated simultaneously. If the LCC function exits due to not meeting the working conditions, the navigation assist function will also exit.
- During the activation of LCC, in order to keep the vehicle centered in the lane, it will automatically control the steering wheel and apply left or right torque. This may give you a certain feeling of forward or reverse force on your hands. However, please keep a light grip on the steering wheel and be ready to take over the steering at any time.
- During the activation process, you can apply torque to the steering wheel to take over lateral control. At this point, the function will downgrade to ACC mode. When you stop actively controlling the steering wheel, the function will resume to centering assist control.

Hint

- When applying the LCC, you can briefly depress the accelerator pedal to operate the vehicle in a short time. At this point, LCC will no longer respond to the target preceding vehicle. When you release the accelerator pedal, the system will control the vehicle to return to the cruise speed.
- The LCC can only be activated when there are clear lane lines on both sides. During the activation process, if the lane line disappears, the LCC will temporarily be downgraded to the ACC state. If the lane line reappears, the function will be restored to the LCC.

III. Operation of LCC

The activation, exit, and setting operations of the LCC function can be achieved by pulling the right side lever on the steering wheel:

- Pull inward twice to activate the LCC function.
- Pull up twice to increase cruising speed or restore cruising speed.
- Pull down to reduce the cruising speed.
- Turn outward to reduce the follow-up time headway.
- Turn inward to increase the follow-up time headway.
- Pull outward once to exit the LCC function.

Warning

- The LCC may unexpectedly exit due to unforeseen circumstances. Please always pay attention to the traffic conditions and road environment, and be ready to take over the vehicle at any time.

IV. LCC speed adjustment

When the LCC is in a activated mode:

- Push the lever on the right side of the steering wheel up to the first gear to increase the cruise speed by 1 km/h.
- Push the lever up to the second gear to increase the cruise speed by the nearest multiple of 5 km/h. For example, if the current cruise speed is set at 57 km/h, pushing up to the second gear will display 60 km/h. When pushing and holding the second gear for a long time, the cruise speed will increase by multiples of 5 km/h.
- Push the lever down to the first gear to decrease the cruise speed by 1 km/h.
- Push the lever down to the second gear to decrease the cruise speed by the nearest multiple of 5 km/h. For example, if the current cruise speed is set at 57 km/h, pushing down to the second gear will display 55 km/h. When pushing and holding the second gear for a long time, the cruise speed will decrease by multiples of 5 km/h.

The maximum set speed for LCC is 130 km/h, and the minimum set speed is 30 km/h, but it can follow to 0 km/h.

Warning

- When using LCC, please strictly adhere to road traffic safety regulations.

V. Follow-up time headway adjustment

There are two gears for adjusting the follow-up time headway, which can be adjusted using the knob switch on the right side of the steering wheel:

- Rotate outward to reduce the time headway, with each click reducing one gear.
- Rotate inward to increase the time headway, with each click increasing one gear.

VI. Follow-up start-stop function

Following: In the following cruise state, the vehicle automatically adjusts its speed and distance based on the speed of the vehicle in front. If the vehicle in front slows down and stops, the vehicle will also brake automatically until it stops.

Starting: If the following vehicle in front starts within 1 min, it will automatically follow up. If the following vehicle in front starts between 1 and 5 min, it will prompt the user to lightly depress the accelerator pedal to confirm following up. If following the vehicle in front for more than 5 min, the vehicle will engage the electronic parking brake (EPB) and exit the LCC function.

Warning

- In some cases, the LCC may not detect traffic participants around the vehicle, or the perception is ineffective or untimely due to interference factors. Therefore, when the vehicle follows and starts,

7 Driving

you need to always pay attention to the traffic conditions and the surrounding road environment to avoid collisions.

VII. LCC function degradation

The following situations may cause the lateral control of LCC to exit, and the function will temporarily downgrade to ACC state. It will resume to LCC when all the following suppression do not exist: Including but not limited to:

- Disappear of lane lines, water accumulation, obstruction, lack of clarity, severe wear, crossing, shadowed by vehicles or buildings.
- Camera field of view is limited, such as rain, snow, fog, smog, sandstorms, obstruction, direct sunlight, nighttime, etc.
- Passing a curve with a large curvature.
- Passing a section without lane lines, such as non-standardized roads, intersections, construction areas, etc.
- Too narrow or wide lane line spacing on both sides of the road.
- Road bumps or steep slopes resulting in inaccurate recognition of lane lines.
- The driver actively exerts excessive steering torque.
- The steering wheel rotation speed is too fast or the steering angle is too large.

When the LCC function is downgraded, it can not control the driving direction of vehicle, which may pose a safety hazard. Therefore, during the use of the LCC function, it is necessary to stay focused, hold the steering wheel with both hands at all times, and always pay attention to the road ahead and traffic conditions, and be ready to take over the vehicle at any time.

VIII. Avoid adjacent vehicle

During the activation of LCC, if a large vehicle (wagon, truck, etc.) from the adjacent lane approaches your line, the vehicle will automatically steer to the other side to maintain a safe distance.

Click “Vehicle Settings → Assisted Driving → Driving Assist → AAV” through the central control screen to activate or deactivate the avoid adjacent vehicle function.

Caution

- Avoid adjacent vehicle (AAV) is suitable for situations where the large vehicle in the adjacent lane has not invaded your lane and there is a safe space on the other side, and your vehicle steers to the other side to evade a certain distance (still within the your lane). Because the road scene is relatively complex and large vehicles are dangerous, in the case of encountering large vehicles, you need to continue to pay attention to the road and be ready to take over the vehicle at any time.

IX. Start and stop at urban traffic lights (If equipped)

During the activation process of the LCC, the function can recognize straight-going traffic lights and assist drivers in passing through intersections. For straight-going lanes, the function will recognize the traffic lights in the straight-going direction and stop at a red light.

The lane at the intersection is complicated, and the traffic lights recognized by the system may not match the actual situation. Please pay attention to the navigation information and control the vehicle if necessary. The current system does not have the ability to turn left and right, so you need to take over manually.

⚠ Caution

- The start-stop function of urban traffic lights is an assisted driving function that cannot handle all traffic, weather and road conditions. As the driver of the vehicle, you are responsible for driving safety. Please hold the steering wheel firmly throughout the journey, observe the road conditions, and take over in time if you encounter danger. Do not rely on this function to control the vehicle, otherwise it may cause injury or even death.
- The function cannot handle all traffic conditions, including but not limited to: multiple traffic lights in the same direction, blocked traffic lights, traffic lights close to intersections, temporary traffic lights, traffic lights at larger intersections, traffic lights at complex intersections, and non-standard traffic lights (irregular traffic lights, composite traffic lights).
- Do not use this function in special scenarios, including but not limited to: scenes with poor visibility (dark, heavy rain, thick fog, etc.), strong light or chaotic lights that affect the camera identification, when the camera is blocked, and when there is traffic police directing traffic.

X. Exit LCC

The LCC function will be deactivated when the following situations occur:

- Pull the gear lever on the right side of the steering wheel outward once.
- Depress the brake pedal.
- Follow the vehicle for more than 5 min.
- The driver's hand-off (not holding the steering wheel) causes the function to exit.

⚠ Warning

- The LCC may unexpectedly exit due to unforeseen circumstances. Please always pay attention to the traffic conditions and road environment, and be ready to take over the vehicle at any time.

7 Driving

Hint

- If the vehicle follows for more than 10 min, the LCC function will exit.
- During the activation of LCC, if the driver's hands are off the steering wheel, a hand-off alarm prompt will be sent. Please ensure that you hold the steering wheel. The alarm has three levels, and after the third level, regardless of whether you take over or not, the function will exit. The inhibition function will be activated within a period of time after exiting, and it needs to be put in P gear before it can take effect again.

XI. Function limitation

In the following scenarios, CLC function may have limited performance or may not be available:

- In a curve with a large curvature.
- Lane lines are unclear, damaged, obstructed, crossed, disconnected, flooded, or covered by shadows.
- Too narrow or wide lane line spacing on both sides of the road.
- On steep slopes, use ACC with caution on steep roads, as there is a risk of the vehicle rolling back when following-up and starting.
- Encountering pedestrians, non-motorized vehicles, lateral traffic participants (such as lateral oncoming vehicles, lateral pedestrians, etc.), oncoming vehicles, and road obstacles (such as cones, guardrails, diversion signs, etc.).

Camera perception-restricted scenarios, including but not limited to:

- Dim lighting conditions causing a decrease in recognition capabilities, such as at night, in the shade, during twilight, in tunnels, or in areas where shadows are cast on the road.
- The camera being obstructed or dirty.
- The camera's installation position being changed or loose, resulting in angle deviation.
- Strong light, backlight, reflection and abrupt changes in brightness, such as direct sunlight during the day, especially in summer, flashlights in the surrounding environment, road surface water reflection, entering or exiting tunnels.
- Extreme weather conditions such as high temperature, severe cold, causing the camera's performance to decline.
- Dust, water vapor, water droplets, dirt, or ice on the windshield in front of the camera, obstructing the camera's field of view.
- Severe weather conditions, such as rain, snow, fog, smog, sandstorms, etc.

Millimeter-wave radar perception-restricted scenarios, including but not limited to the following situations:

- The radar's installation position being changed or loose, resulting in angle deviation.
- The radar being obstructed by mud, ice, metal objects, etc.

- Extreme weather conditions such as high temperature, severe cold, causing the radar's perception capabilities to decline.
- Vehicle collisions causing the radar's installation position area to be hit or the vehicle surface to be deformed.
- Electromagnetic field interference in the surrounding environment, such as heavy fog, rain, snow, or sandstorms.
- Due to the limitation of the characteristics of radar electromagnetic waves, there may be misidentification in some special scenarios, such as metal guardrail, green belt, cement wall, construction area, etc.

Only standard vehicle targets will be recognized and responded to. The following target scenarios cannot be recognized, including but not limited to:

- Horizontal vehicle target.
- Pedestrians or two-wheeled, three-wheeled, and other motorized vehicles.
- Road obstacles, such as water horses, crash cushions, cones, posts, triangular warning signs, etc.
- Vehicles driving across or in the opposite direction.
- Non-vehicle targets such as fences, traffic lights, road signs, barrier poles, walls, animals, etc.
- Special vehicle targets such as construction vehicles, engineering vehicles, heterogeneous vehicles, etc.

In the following scenarios, if the relative speed to the vehicle in front is too high, the LCC may not brake and decelerate in time:

- The vehicle ahead is stationary or moving slowly, especially at night or during uphill or downhill driving, where recognition may be delayed.
- The vehicle ahead suddenly brakes.
- A vehicle in an adjacent lane cuts into the path ahead of your vehicle.
- Your vehicle suddenly cuts into the path behind the vehicle in front.

Warning

- The LCC is a comfort driving assist function. In any situation, you need to continuously monitor the road conditions and maintain active control of the vehicle.
- The LCC cannot detect all obstacles. If the vehicle or an obstacle in front is only partially in the lane, or if your vehicle is partially in the lane, the LCC may not apply the brakes or decelerate. Please remain vigilant and be prepared to take over the vehicle at any time.
- It is not recommended to use LCC function in adverse weather conditions such as rain, snow, fog, smog, sandstorms, road puddles, icy roads, etc.

7 Driving

- The LCC is suitable for use on highways, national roads, main roads and other straight roads. It is not recommended to use LCC on muddy, narrow, non-standardized roads, uphill and downhill roads, sharp turns, crowded and crossroads with complex traffic conditions.
- It is not recommended to use LCC in complex traffic scenarios such as busy city areas, pedestrian or bicycle-heavy roads, intersections and congested sections.
- The above warnings and limitations do not cover all possible situations that may affect the normal operation of the LCC function. During use, various factors may interfere with the LCC operation. To avoid safety incidents, please stay focused and always pay attention to the traffic environment, road conditions and vehicle status.

7.6.5 Commanded lane change

I. CLC

Commanded lane change (CLC) is based on the activation of LCC or NOC functions. If the vehicle has enabled the CLC function and meets the activation conditions, the left/right steering wheel lever can be used to control the vehicle to complete the lane change. CLC is mainly suitable for dry, smooth and clearly marked standardized long straight roads, such as highways, urban expressways, highways, long straight trunk roads, etc.

Click "Vehicle Settings → Assisted Driving → Driving Assist → CLC" through the central control screen to activate or deactivate the CLC function. When using the CLC function, the following requirements must be met:

- The front view camera and millimeter-wave radar functions are normal, with clear vision.
- The LCC function is activated.
- The driver holds the steering wheel.
- The current speed is greater than 40 km/h.
- The vehicle is driving on a straight road.

The current lane and the target lane meet the safe lane change conditions, including but not limited to:

- The lane line on the change side is a dashed line or a dashed solid line.
- There is a safe lane change space on the target lane (with open space at the front and rear).
- Your vehicle maintains a sufficient safe distance with the vehicle in front in the current lane.
- There are no blind spot monitoring or lane change assist alarms in the target lane
- The curvature of both the current lane and the target lane is relatively small.
- The lane lines of the current lane and the target lane are clear.

You should judge whether the conditions for changing lanes are met. Before changing lanes, please visually check again and confirm that the environment for changing lanes is safe, and then pull the corresponding side turn signal light lever.

After the turn signal light is turned on, if the system detects that the lane change conditions are met, it will execute the lane change. If the system judges that the current lane change conditions are not met, it will directly terminate the lane change. Or if the waiting conditions are met, it will continue to wait for a period of time to seek a lane change opportunity. If there is still no lane change opportunity after 30 s, the lane change will be terminated.

During the lane change process, you can cancel the current lane change by pulling back the turn signal light lever or reversing the turn signal light lever. If the vehicle center has already crossed the lane line during cancellation, the lane change will continue to be completed. If the vehicle center has not crossed the lane line, it will be pulled back to the original lane.

When changing lanes, if any of the following situations occur, CLC will pause the lane change and continue to wait for the opportunity:

7 Driving

- Lane change side blind spot monitoring or lane change assist alarm is activated.
- There are vehicles ahead in the target lane, and there is currently no lane change space.

Caution

- The CLC can only be performed once each time.

Warning

- When using CLC, please strictly comply with road traffic safety regulations, including but not limited to vehicle speed regulations.
- The CLC may unexpectedly exit due to unforeseen circumstances. Please always pay attention to the traffic conditions and road environment, and be ready to take over the vehicle at any time.
- The CLC is merely a lane change assist system. Before and during lane changes, you must remain focused at all times, confirming that the lane change process and vehicle movement are safe. Please note that the CLC cannot respond to pedestrians, two-wheelers, non-vehicular obstacles, oncoming vehicles, etc. Do not rely solely on the driving path judged by the CLC. You always bear the ultimate responsibility for safe lane changes.

II. Function limitation

In the following scenarios, the CLC function may have limited performance or may not be available, requiring you to be ready to take over the vehicle at any time, including but not limited to:

- In a curve with a large curvature.
- Lane lines are unclear, damaged, obstructed, crossed, disconnected, flooded, or covered by shadows.
- Too narrow or wide lane line spacing on both sides of the road.
- On steep slopes, use ACC with caution on steep roads, as there is a risk of the vehicle rolling back when following-up and starting.

Camera perception-restricted scenarios, including but not limited to:

- Dim lighting conditions causing a decrease in recognition capabilities, such as at night, in the shade, during twilight, in tunnels, or in areas where shadows are cast on the road.
- The camera being obstructed or dirty.
- The camera's installation position being changed or loose, resulting in angle deviation.
- Strong light, backlight, reflection and abrupt changes in brightness, such as direct sunlight during the day, especially in summer, flashlights in the surrounding environment, road surface water reflection, entering or exiting tunnels.
- Extreme weather conditions such as high temperature, severe cold, causing the camera's performance to decline.

- Dust, water vapor, water droplets, dirt, or ice on the windshield in front of the camera, obstructing the camera's field of view.
- Severe weather conditions, such as rain, snow, fog, smog, sandstorms, etc.

Millimeter-wave radar perception-restricted scenarios, including but not limited to the following situations:

- The radar's installation position being changed or loose, resulting in angle deviation.
- The radar being obstructed by mud, ice, metal objects, etc.
- Extreme weather conditions such as high temperature, severe cold, causing the radar's perception capabilities to decline.
- Vehicle collisions causing the radar's installation position area to be hit or the vehicle surface to be deformed.
- Electromagnetic field interference in the surrounding environment, such as heavy fog, rain, snow, or sandstorms.
- Due to the limitation of the characteristics of radar electromagnetic waves, there may be misidentification in some special scenarios, such as metal guardrail, green belt, cement wall, construction area, etc.

Only standard vehicle targets will be recognized and responded to. The following target scenarios cannot be recognized, including but not limited to:

- Horizontal vehicle target.
- Vehicles driving across or in the opposite direction.
- Pedestrians or two-wheeled, three-wheeled, and other motorized vehicles.
- Road obstacles, such as water horses, crash cushions, cones, posts, triangular warning signs, etc.
- Vehicles driving across or in the opposite direction.
- Non-vehicle targets such as fences, traffic lights, road signs, barrier poles, walls, animals, etc.
- Special vehicle targets such as construction vehicles, engineering vehicles, heterogeneous vehicles, etc.

Caution

- During the CLC process, if there is a vehicle in the adjacent lane simultaneously changing lanes to the target lane, due to distance and angle, the CLC may not be able to recognize it. Please be aware to take over the vehicle for avoidance.
- The CLC may miss detecting stationary or slowly moving vehicles, especially at night, so please be particularly careful.

7 Driving

Warning

- The CLC is a comfort lane change assist function. In any situation, you need to continuously monitor the road conditions and maintain active control of the vehicle.
- It is not recommended to use the CLC in adverse weather conditions such as rain, snow, fog, smog, sandstorms, road puddles, icy roads, etc.
- The CLC is suitable for high-speed driving scenarios on straight roads such as highways, national roads, main roads. It is not recommended to use this function on muddy, narrow, non-standardized roads, uphill and downhill roads, sharp turns, crowded and crossroads with complex traffic conditions.
- It is not recommended to use CLC in complex traffic scenarios such as busy city areas, pedestrian or bicycle-heavy roads, intersections and congested sections.
- The above warnings and limitations do not cover all possible situations that may affect the normal operation of CLC. During use, various factors may interfere with CLC. To avoid safety incidents, please stay focused and always pay attention to the traffic environment, road conditions and vehicle status.

7.6.6 RCW

Rear Collision Warning (RCW) : When a vehicle is moving forward and detects that it may be rear-ended by a vehicle behind, it will issue an audible and visual alarm to warn the driver, and at the same time flash the hazard warning light to remind the vehicle behind to slow down and avoid collision.

I. Setting

Turn on the early warning + braking function by clicking "Vehicle Settings → Assisted Driving → Active Safety → Rear Collision Warning" through the central control screen.

- Select "Not enable" to turn off the forward collision warning function.
- Select "Warning" or "Warning + Braking" to enable the rear collision warning function.

II. Function activation

The rear collision warning function will be activated when the following conditions are met:

- The vehicle speed is between 0km/h and 130km/h.
- The vehicle is in non-P gear.
- There is a risk of a rear-end collision with the vehicle behind.

Caution

- The rear collision warning function is set to be enabled by default each time the vehicle is powered on.
- When selecting the warning function, the system will only send warning prompts in a dangerous situation and will not take braking measures.

Hint

- When the rear collision warning function is triggered, a text pop-up + strong sound alarm prompt will appear on the instrument panel. When the situation is more dangerous, there will also be accompanied by tactile alarms such as steering wheel vibration and light braking.

III. Function limitation

In the following situations, the rear collision warning function may be limited or unable to operate normally, including but not limited to:

- When the risk vehicle behind is not in the same lane as your vehicle.
- When the vehicle behind is an irregular car or a motorcycle.
- When the reversing lights, turn signals, hazard warning lights or emergency brake signal lights are turned on.
- The target that can only be detected after the car changes lanes.
- The target in the curve.

7 Driving

- Uphill or downhill roads or bumpy roads.
- Scenarios where sensors are limited.

Camera perception-restricted scenarios, including but not limited to:

- Dim lighting conditions causing a decrease in recognition capabilities, such as at night, in the shade, during twilight, in tunnels, or in areas where shadows are cast on the road.
- The camera being obstructed or dirty.
- The camera's installation position being changed or loose, resulting in angle deviation.
- Strong light, backlight, reflection and abrupt changes in brightness, such as direct sunlight during the day, especially in summer, flashlights in the surrounding environment, road surface water reflection, entering or exiting tunnels.
- Extreme weather conditions such as high temperature, severe cold, causing the camera's performance to decline.
- Dust, water vapor, water droplets, dirt, or ice on the windshield in front of the camera, obstructing the camera's field of view.
- Severe weather conditions, such as rain, snow, fog, smog, sandstorms, etc.

Millimeter-wave radar perception-restricted scenarios, including but not limited to the following situations:

- The radar's installation position being changed or loose, resulting in angle deviation.
- The radar being obstructed by mud, ice, metal objects, etc.
- Extreme weather conditions such as high temperature, severe cold, causing the radar's perception capabilities to decline.
- Vehicle collisions causing the radar's installation position area to be hit or the vehicle surface to be deformed.
- Electromagnetic field interference in the surrounding environment, such as heavy fog, rain, snow, or sandstorms.
- Due to the limitation of the characteristics of radar electromagnetic waves, there may be misidentification in some special scenarios, such as metal guardrail, green belt, cement wall, construction area, etc.

Warning

- The rear collision warning function is a driving assist function. This function cannot replace the driver's observation and judgment of traffic conditions, as well as the driver's responsibility for driving the vehicle safely. When the function issues an alarm, the driver should immediately take corrective measures to prevent collision accidents from occurring.

7.6.7 Shadow area detection aid

Blind spot detection (BSD) assist. When your vehicle speed is between 10 km/h and 150 km/h, if there is a vehicle moving or rapidly approaching in the blind spot on the side or diagonally behind your vehicle, the vehicle will alert the driver through instrument prompt, steering wheel vibration and indicator lights on the exterior rearview mirror.

I. Setting

To enable or disable BSD warning, click “Vehicle Settings → Assisted Driving → Active Safety → BSD Warning” through the central control screen.

- Select “Not enable” to turn off the BSD warning.
- Select “Lights” to enable BSD warning with only external mirror indicators alerting the driver.
- Select “Vibration + Lights” to enable BSD warning, alerting the driver through steering wheel vibration and external mirror indicators.

II. Prompt information

When the side blind spot assist is in the alarm state, the indicator light on the exterior rearview mirror on the corresponding side illuminates, with a yellow sector symbol on the corresponding side displayed in the instrument screen.

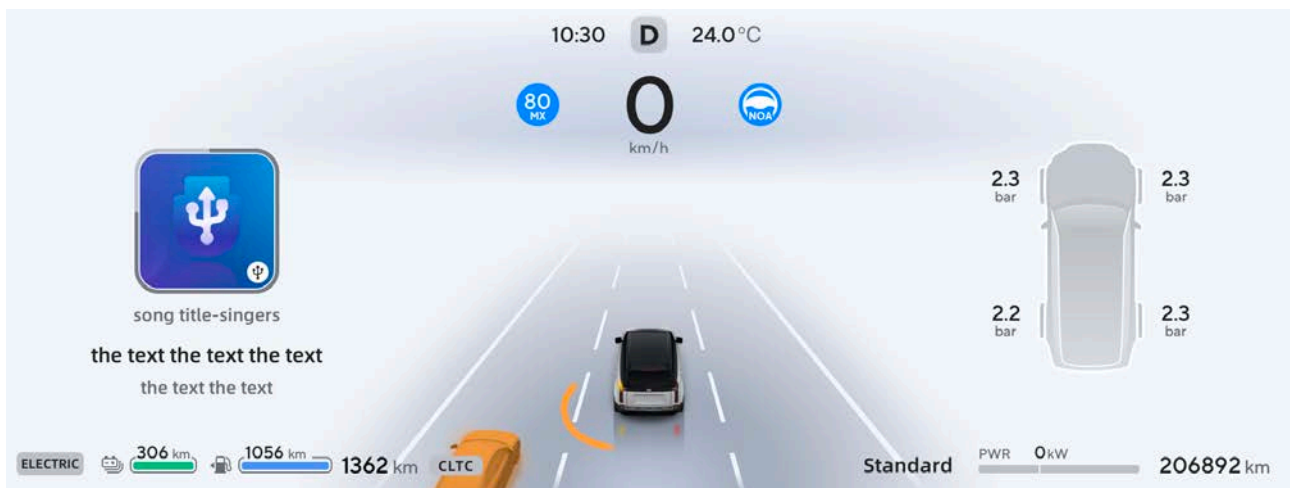

If the turn signal light on this side is activated at this time, the exterior mirror indicator on the corresponding side will flash, and the steering wheel will vibrate to alert the driver, with the sector area on the instrument panel turning red.

7 Driving

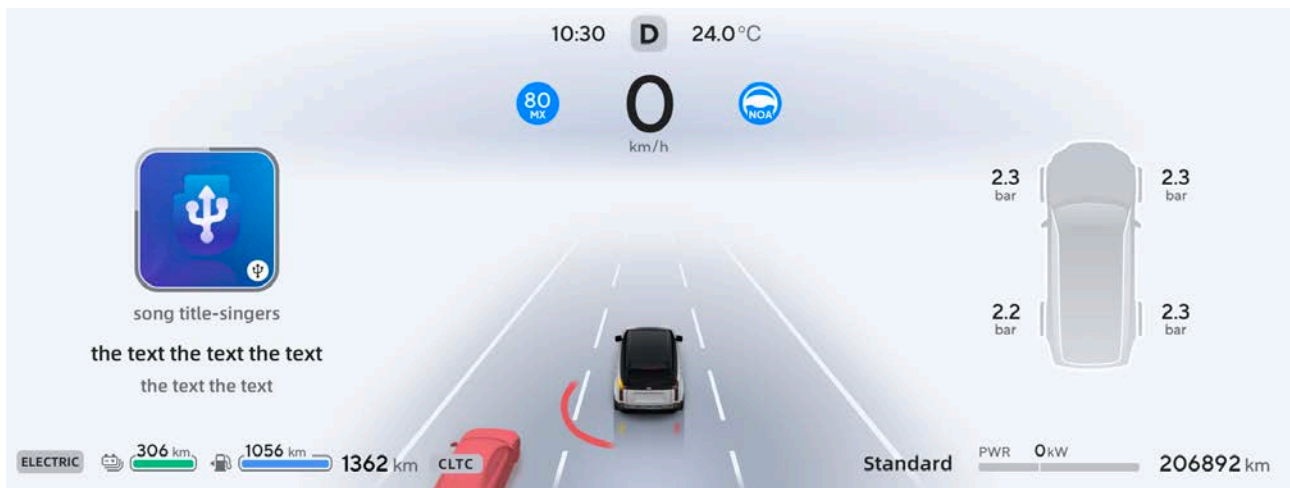

III. Function limitation

Camera perception-restricted scenarios, including but not limited to:

- Dim lighting conditions causing a decrease in recognition capabilities, such as at night, in the shade, during twilight, in tunnels, or in areas where shadows are cast on the road.
- The camera being obstructed or dirty.
- The camera's installation position being changed or loose, resulting in angle deviation.
- Strong light, backlight, reflection and abrupt changes in brightness, such as direct sunlight during the day, especially in summer, flashlights in the surrounding environment, road surface water reflection, entering or exiting tunnels.
- Extreme weather conditions such as high temperature, severe cold, causing the camera's performance to decline.
- Dust, water vapor, water droplets, dirt, or ice on the windshield in front of the camera, obstructing the camera's field of view.
- Severe weather conditions, such as rain, snow, fog, smog, sandstorms, etc.

Millimeter-wave radar perception-restricted scenarios, including but not limited to the following situations:

- The radar's installation position being changed or loose, resulting in angle deviation.
- The radar being obstructed by mud, ice, metal objects, etc.
- Extreme weather conditions such as high temperature, severe cold, causing the radar's perception capabilities to decline.
- Vehicle collisions causing the radar's installation position area to be hit or the vehicle surface to be deformed.
- Electromagnetic field interference in the surrounding environment, such as heavy fog, rain, snow, or sandstorms.

- Due to the limitation of the characteristics of radar electromagnetic waves, there may be misidentification in some special scenarios, such as metal guardrail, green belt, cement wall, construction area, etc.

Warning

- The BSD function is a driving assist function. This function cannot replace the driver's observation and judgment of traffic conditions, as well as the driver's responsibility for driving the vehicle safely.

7 Driving

7.6.8 CTA

Cross traffic alert (CTA). When your vehicle speed is less than 15 km/h, and a vehicle is detected crossing through the left and right blind spots in front of or behind the vehicle, the vehicle will send a prompt message on the instrument panel.

I. Setting

You can enable or disable the CTA function by clicking “Vehicle Settings → Assisted Driving → Active Safety → CTA” through the central control screen.

II. Function limitation

Camera perception-restricted scenarios, including but not limited to:

- Dim lighting conditions causing a decrease in recognition capabilities, such as at night, in the shade, during twilight, in tunnels, or in areas where shadows are cast on the road.
- The camera being obstructed or dirty.
- The camera’s installation position being changed or loose, resulting in angle deviation.
- Strong light, backlight, reflection and abrupt changes in brightness, such as direct sunlight during the day, especially in summer, flashlights in the surrounding environment, road surface water reflection, entering or exiting tunnels.
- Extreme weather conditions such as high temperature, severe cold, causing the camera’s performance to decline.
- Dust, water vapor, water droplets, dirt, or ice on the windshield in front of the camera, obstructing the camera’s field of view.
- Severe weather conditions, such as rain, snow, fog, smog, sandstorms, etc.

Millimeter-wave radar perception-restricted scenarios, including but not limited to the following situations:

- The radar’s installation position being changed or loose, resulting in angle deviation.
- The radar being obstructed by mud, ice, metal objects, etc.
- Extreme weather conditions such as high temperature, severe cold, causing the radar’s perception capabilities to decline.
- Vehicle collisions causing the radar’s installation position area to be hit or the vehicle surface to be deformed.
- Electromagnetic field interference in the surrounding environment, such as heavy fog, rain, snow, or sandstorms.
- Due to the limitation of the characteristics of radar electromagnetic waves, there may be misidentification in some special scenarios, such as metal guardrail, green belt, cement wall, construction area, etc.

Warning

- The CTA is a driving assist function. This function cannot replace the driver's observation and judgment of traffic conditions, as well as the driver's responsibility for driving the vehicle safely.

7 Driving

7.6.9 DOW

Door open warning (DOW). When the vehicle is stationary or the speed is less than 5 km/h, and passengers are opening the door to exit, the system will send an alarm prompt through the instrument panel and exterior mirrors when detecting approaching vehicles from the side and rear. Thereby reducing the risk of collision with other vehicles when exiting.

I. Setting

You can enable or disable the DOW function by clicking "Vehicle Settings → Assisted Driving → Active Safety → DOW".

II. Prompt information

When the vehicle is stationary and detects an approaching vehicle from the side and rear, the indicator on the corresponding side exterior mirror remains on, and the corresponding side of the instrument panel displays a yellow sector symbol.

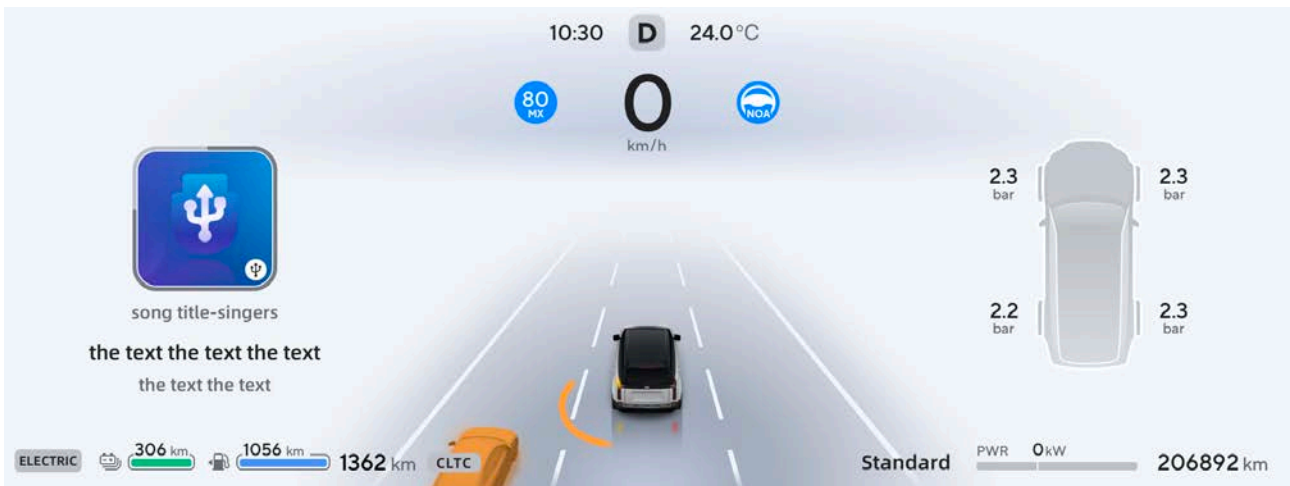

When it is detected that there is an approaching vehicle on the side and rear and the corresponding side door is opening, the indicator on the exterior mirror flashes quickly, and the yellow sector inside the instrument panel turns red.

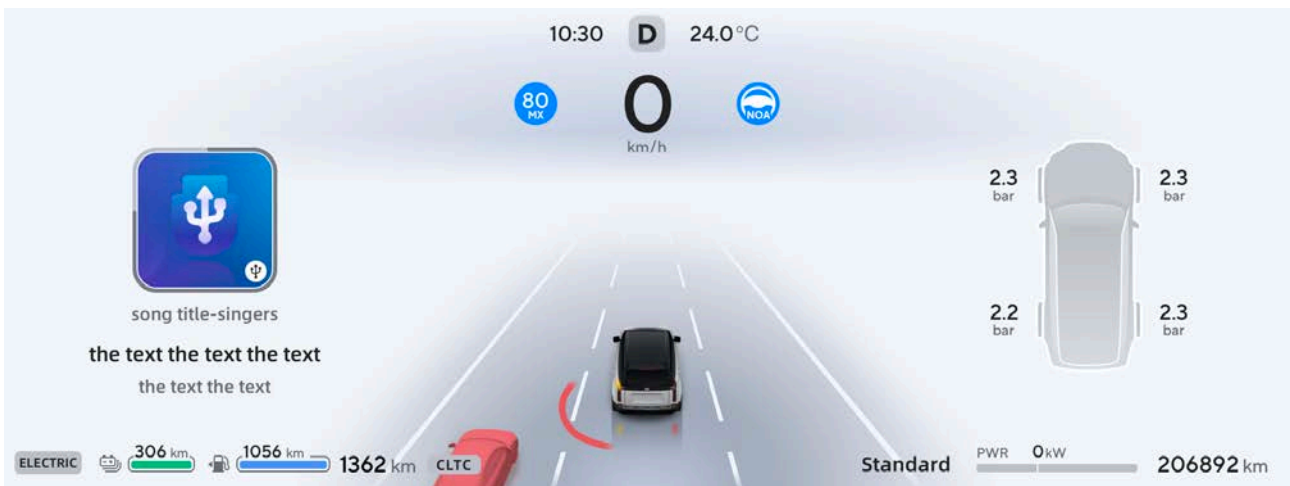

III. Function limitation

- The DOW function will not send an alarm for oncoming vehicles.
- The function's activation may be delayed in response to rapidly approaching target vehicles.
- The function's activation may be delayed or may not trigger at all for smaller targets such as pedestrians, bicycles and motorcycles.

Camera perception-restricted scenarios, including but not limited to:

- Dim lighting conditions causing a decrease in recognition capabilities, such as at night, in the shade, during twilight, in tunnels, or in areas where shadows are cast on the road.
- The camera being obstructed or dirty.
- The camera's installation position being changed or loose, resulting in angle deviation.
- Strong light, backlight, reflection and abrupt changes in brightness, such as direct sunlight during the day, especially in summer, flashlights in the surrounding environment, road surface water reflection, entering or exiting tunnels.
- Extreme weather conditions such as high temperature, severe cold, causing the camera's performance to decline.
- Dust, water vapor, water droplets, dirt, or ice on the windshield in front of the camera, obstructing the camera's field of view.
- Severe weather conditions, such as rain, snow, fog, smog, sandstorms, etc.

Millimeter-wave radar perception-restricted scenarios, including but not limited to the following situations:

- The radar's installation position being changed or loose, resulting in angle deviation.
- The radar being obstructed by mud, ice, metal objects, etc.
- Extreme weather conditions such as high temperature, severe cold, causing the radar's perception capabilities to decline.
- Vehicle collisions causing the radar's installation position area to be hit or the vehicle surface to be deformed.
- Electromagnetic field interference in the surrounding environment, such as heavy fog, rain, snow, or sandstorms.
- Due to the limitation of the characteristics of radar electromagnetic waves, there may be misidentification in some special scenarios, such as metal guardrail, green belt, cement wall, construction area, etc.

Warning

- The DOW is a driving assist function. This function cannot replace the driver's observation and judgment of traffic conditions, as well as the driver's responsibility for driving the vehicle safely.

7 Driving

7.6.10 Assisted parking

The assisted parking system obtains information about surrounding parking lots, spaces and obstacles with the ultrasonic radar and 360-degree cameras. It processes the information in real-time to calculate the vehicle's parking route and controls the steering system, braking system and powertrain system in coordination to control the vehicle's steering wheel, brakes, gearshift, and other components to complete the parking process.

The assisted parking function includes parking space search, parking space recognition, parking space selection, horizontal parking, vertical parking and inclined parking.

During the assisted parking process, the driver needs to maintain concentration and observes the vehicle's actions and the surrounding environment. This helps ensure the smooth progress of the parking process and allows for manual intervention when necessary.

I. Assisted parking in

1. Enter the assisted parking interface by clicking the parking icon in the function bar at the bottom of the central control screen.
2. Search for a parking lot

Before enable the search for parking lot, the following conditions must be met:

- The assisted parking function is enabled.
- The assisted parking system is fault-free.
- Exterior rearview mirrors are not folded.
- The speed is less than 25 km/h.
- All vehicle doors, trunk doors and engine hood are closed.
- The assisted parking tutorial has been completed.
- Occupants fasten their seat belts.

You can enter the parking lot search interface in the following ways:

- When driving at a speed below 20 km/h, the system automatically searches for parking lot. When a parking lot is found, the left side 3D simulation view on the central control screen displays the corresponding parking lot. It displays a maximum of 7 on each side of the vehicle, including horizontal, vertical, and inclined lots. If a parking lot is detected but no vehicle is detected in it, it displays a vacant parking lot. If a parking lot is detected and a vehicle is detected parking in it, it displays that a car parking in the parking lot.

3. Find a parking lot

When the system detects a parking lot, the central control screen will display the available parking lot accompanied by a sound prompt.

After detecting a parking lot, the driver depresses the brake pedal, and the system automatically recommends and selects a parking lot by default, and highlights it. The driver may manually select other parking lot and highlight it. The previously selected parking lot will no longer be highlighted.

Warning

- As a driver, you are responsible for the safe parking of the vehicle.
- Even after the system finds a parking lot, you must manually confirm whether the environment meets the parking conditions and should not rely solely on the parking system.
- Pay attention to the surrounding environment and be prepared to take over the vehicle at any time based on the environment or system prompts.
- The system may mistakenly identify parking lot in shrubbery, corridors, or intersections, and you need to judge whether the parking lot is correct.

4. Start parking

After selecting a parking lot, keep the vehicle stationary, click “Start Parking,” release the brake pedal and steering wheel, and the vehicle will start assisted parking. If the driver depresses the brake pedal, it enters the parking standby state.

Warning

- After starting to park, remove your hands from the steering wheel and ensure your body is not in the steering wheel’s operating range to avoid injury caused by steering wheel rotation.
- Release the brake pedal only after a release message displaying in the central control screen, otherwise, the vehicle may slide.

5. Pause parking

When the vehicle is in the process of parking, the parking function will enter the suspended state if the door is opened, the trunk is opened, the brake pedal is depressed, the rearview mirror is folded, the seat belt is not fastened, and an obstacle is detected on the parking path. If the obstacle causes a pause, you need to confirm the environment is safe before deciding whether to continue parking.

In the paused state, clicking the “Continue” icon on the central control screen will resume the assisted parking.

6. Parking completed

After parking is completed, turn off the assisted parking function, and the central control screen will return to the main page.

II. Function limitation

The parking assist system cannot perform park out under conditions that mechanical system does not meet. This may affect the parking effect or cannot park in parking lot, including but not limited to:

- Non-original size tires are used.
- Tire pressure is insufficient or inconsistent.

7 Driving

- Snow chains are installed.

The parking assist system is an assisted driving system, and the application of system functions has strict restrictions and cannot replace the driver's responsibility for monitoring the driving environment and operating the vehicle:

- The driver cannot rely entirely on the parking assist system in any situation.
- In adverse weather conditions, such as heavy rain, heavy fog, heavy snow, etc., the system function may decrease. In such cases, the detection performance of parking lot lines and obstacles will be reduced or even cannot be detected.
- Sensors cannot detect parking lot lines and obstacles in all situations.
- Some targets will affect and weaken the detection of 360 camera sensors, such as ground shadows, ground potholes, unclear parking lot lines, other lines interfering, ice and snow or rain coverage, curb, and patches in the parking lot, thereby affecting the parking assist function.
- Parking lots with odd-shaped obstacles or suspended obstacles in or near the parking lot are not suitable for assisted parking.
- On the edge of cliffs or ditches, the assisted parking performance may be limited or may malfunction.
- At night, the performance of the assisted parking system will decrease.
- The calibration of the 360-degree camera sensor will be affected when subjected to strong vibration or slight impact, which will reduce system performance or increase the malfunction rate. The installation position of the 360-degree camera sensor needs to be checked or recalibrated.

The assisted parking system is not suitable for use in all scenarios, and the following situations require particular attention:

- Obstacles close to parking lot

When there are obstacles close to the parking lot (such as obstacles close to parking lot lines or partially intruding into the lot with concrete pillars), due to the limitations of sensors, there may be some error in judging the distance to the obstacle. The user needs to be vigilant and take over the vehicle when they detect the risk of scratching.

- Suspended obstacles

When there are suspended obstacles (such as fire extinguisher boxes, vehicle spare tires, truck tailgates), due to the limitations of sensors, it may not detect the obstacle, or the detection effect may not be good. There is a risk of scratching. Do not choose such parking lots for parking.

- Special shape obstacles

When there are special shape obstacles (such as right-angle concrete pillars, tow hooks, sharp corner obstacles, irregular shaped obstacles), due to the weak return information of obstacles received by the sensors, there may be non-recognition or late recognition. There is a risk of collision and scratching. Please stay alert and be ready to take over the vehicle at any time.

7.6.11 Assisted remote parking

Assisted remote parking is a function that detects obstacles and parking lot lines on both sides of the vehicle based on ultrasonic radars and 360 cameras distributed around the vehicle. After calculating and analyzing the distance to obstacles and the position of parking lot lines, and calculating the parking trajectory, it controls other systems of the complete vehicle to automatically park the vehicle into the target parking lot.

I. Remote parking in

1. After successfully searching for a parking lot through the central control screen, select the parking lot you want to park into, click the “Assisted Remote Parking” button. At this time, you need to put the vehicle in P gear and turn on the electronic handbrake.
2. Before using the assisted remote parking function, ensure that the phone’s Bluetooth and location permissions are turned on, turn on the APP’s phone key switch and connect the vehicle. After the connection is successful, enter the ROX APP, click the “Assisted Remote Parking” button to perform remote parking.
3. After entering the assisted remote parking interface, press and hold the “Long Press Parking In” button to control the vehicle into the selected parking lot. Release the “Long Press Parking In” button to pause parking.

II. Assisted straight-line summon

The assisted straight-line summon function acts as a supplement to the assisted parking function. When the vehicle is parked in a narrow space and the driver finds it inconvenient to get in or out, it can activate the assisted straight-line summon function through the phone APP to control the vehicle to move forward and backward in a straight line, making the driver more convenient to park or pick up the vehicle.

1. The entry point for assisted straight-line summon is the same as for assisted remote parking.
2. The driver can control the forward or backward movement of the vehicle according to the actual situation through the ROX APP.
 - Press and hold the forward button, and the vehicle moves forward in a straight line. Release the button, and the vehicle stops moving and remains stationary.
 - Press and hold the reverse button, and the vehicle moves backward in a straight line. Release the button, and the vehicle stops moving and remains stationary.

III. Abnormal handling of assisted remote parking

Abnormalities during parking in can be divided into recoverable interruptions and non-recoverable interruptions. Recoverable interruptions will continue to run after the abnormality disappears, and the parking function can support continuing to complete the parking process. After a non-recoverable interruption occurs, the parking process will directly exit, and the parking cannot continue. Recoverable interruption scenarios include:

- Obstacles appearing in the parking path.

7 Driving

- Door opening/trunk opening/hood opening.
- The rearview mirror being folded.
- Bluetooth connection being interrupted.
- Bluetooth connection distance being overrun.

Non-recoverable interruption scenarios include:

- Parking interruption timeout.
- Parking process timeout.
- Route planning failed.
- Too high vehicle speed.
- Intervention with the accelerator pedal or steering wheel.
- The current road slope being too large.
- Shifting into P gear or engaging the handbrake failed.
- Too many interruptions or movements.
- Intervention with shifting or shifting failed.
- Parking system failed.
- Parking lot limit.
- Intervention with the handbrake.

IV. Functional limitations

The assisted remote parking system is an assisted driving system, and the application of system functions has strict restrictions and cannot replace the driver's responsibility for monitoring the driving environment and operating the vehicle:

- The driver cannot rely on the RPA system in any situation.
- In adverse weather conditions, such as heavy rain, heavy fog, heavy snow, etc., the system function may decrease. In such cases, the detection performance of parking lot lines and obstacles will be reduced or even cannot be detected.
- Sensors cannot detect parking lot lines and obstacles in all situations.
- Some targets will affect and weaken the detection of 360-degree camera sensors, such as ground shadows, ground potholes, unclear parking lot lines, other lines interfering, ice and snow or rain coverage, curb, and patches in the parking lot, thereby affecting the assisted remote parking function.
- Parking lots with odd-shaped obstacles or suspended obstacles in or near the parking lot are not suitable for the assisted remote parking function.
- On the edge of cliffs or ditches, the assisted remote parking performance may be limited or may malfunction.
- At night, the performance of the assisted remote parking system will decrease.

- The calibration of the 360-degree camera sensor will be affected when subjected to strong vibration or slight impact, which will reduce system performance or increase the malfunction rate. The installation position of the 360-degree camera sensor needs to be checked or recalibrated.

The assisted remote parking system is not suitable for use in all scenarios, and the following situations require particular attention:

- Obstacles close to parking lot

When there are obstacles close to the parking lot (such as obstacles close to parking lot lines or partially intruding into the lot with concrete pillars), due to the limitations of sensors, there may be some error in judging the distance to the obstacle. The user needs to be vigilant and take over the vehicle when they detect the risk of scratching.

- Suspended obstacles

When there are suspended obstacles (such as fire extinguisher boxes, vehicle spare tires, truck tailgates), due to the limitations of sensors, it may not detect the obstacle, or the detection effect may not be good. There is a risk of scratching. Do not choose such parking lots for parking.

- Special shape obstacles

When there are special shape obstacles (such as right-angle concrete pillars, tow hooks, sharp corner obstacles, irregular shaped obstacles), due to the weak return information of obstacles received by the sensors, there may be non-recognition or late recognition. There is a risk of collision and scratching. Please stay alert and be ready to take over the vehicle at any time.

Warning

- Drivers must always pay attention to the parking conditions and the surrounding environment of the vehicle. If necessary, they should immediately stop parking; otherwise, it may cause serious property damage, personal injury or death.

7 Driving

7.6.12 Around view monitoring

Around view monitoring (AVM) provides a panoramic view of the vehicle's surroundings, including forward, rear and side views. This allows the driver to clearly understand the surrounding environment, including obstacles, pedestrians, other vehicles, parking lots, etc. The AVM helps the driver better assess the vehicle's position and distance for safe driving and parking.

The AVM provides: regular viewing angle and wheel hub viewing angle. You can switch view angle to any position as needed to observe the vehicle's surroundings.

I. Entering AVM

1. Manual entry

To manually enter the AVM interface, you can:

- Wake up the voice system and say wake words such as "Turn on AVM".
- Click the "AVM" icon at the bottom of the central control screen's function bar.

2. Automatic entry

Automatically enter the AVM interface in the following ways:

- The vehicle's power is not in the "OFF" mode, and the gear is shifted to R.
- When the vehicle is in R gear, the vehicle speed is less than 20 km/h (only applicable to high order).
- When the vehicle is in D gear, an obstacle is detected in front of the vehicle.
- When the vehicle is in N gear, the vehicle slides and an obstacle is detected behind the vehicle.
- When the vehicle is in D gear, obstacles are detected on both sides of the vehicle.
- Turn on the turn signal light.
- Enter a narrow road.
- Automatically/remotely park.

II. Exit AVM

1. Manual exit

To manually exit the AVM interface, you can:

- Wake up the voice system and say wake words such as "Turn off AVM".
- Click the "AVM" icon at the bottom of the central control screen's function bar.

2. Automatic exit

Automatically exit the AVM interface in the following ways:

- The gear is shifted to P.
- The speed exceeds 20 km/h.
- Leave a narrow road.
- The obstacle disappears.
- In D/N gear, there is no radar trigger, no turn signal light trigger, and no user operation.

III. View switching

The AVM has two view angles: Regular view and wheel hub view.

In the AVM interface, clicking “Regular View” will display a top-down view with front, left, right, and rear views.

Switching to the wheel hub view will display the front and rear wheel views of the vehicle.

Hint

- When there is no view switching for 3 s, the view switching button will automatically hide. You can manually select a view by clicking on the body of the vehicle.

IV. Single side view switching

When the regular view is selected, clicking on the front, rear, left or right icon to switch to the corresponding side view.

- Front view

Manual switching: When the view is full-screen, click the front view icon to switch to the front view angle.

Automatic switching: When the AVM mode is enabled and the vehicle is in another view, switch to D gear to automatically switch to the front view or switch to the front view angle when an obstacle is detected ahead.

- Rear view

Manual switching: When the view is full-screen, click the rear view icon to switch to the rear view angle.

Automatic switching: When the vehicle switches to R gear or when an obstacle is detected behind the vehicle, it will automatically switch to the rear view angle.

Hint

- The left and right views can only be switched by manual clicking.

V. Combined view

The combined view is composed of the front view, left view and right view. It is triggered by conditions such as turn signal lights and narrow roads.

VI. Driving assist line

When the AVM function is activated, if the vehicle is not in P gear or the electronic handbrake is not activated, the AVM system will display the corresponding driving assist lines based on the gear position.

- Dynamic trajectory line: It changes in real-time according to the direction of the steering wheel rotation.

7 Driving

VII. Tailgate opening reminder

During the process of reversing into a parking lot (including vertical and horizontal parking lots), to avoid the situation where the vehicle has been parked and the trunk cannot be opened, it needs to restart the vehicle and move forward before the tailgate can be opened normally. When the tailgate opening reminder function is turned on and the vehicle detects the real-time distance to the wall or other obstacles, if the distance exceeds the opening distance, the trunk door (including the spare tire) does not have enough space to open, the central control screen will prompt.

VIII. Reverse radar

By clicking the sound icon in the AVM control interface, you can turn on or off the reverse radar sound prompt. It is turned on by default. It will be turned on by default the next time the vehicle is started.

Hint

- The vehicle will prompt different frequencies of alarm sounds according to different obstacle distances.

7.6.13 Emergency brake assist

During driving, if the system determines that there is a significant risk of collision between the vehicle and the vehicle ahead, two-wheeled vehicle or pedestrian, the system will actively apply emergency braking to reduce the vehicle speed, thereby avoiding or mitigating collision damage.

For stationary vehicles, pedestrians, or two-wheeled targets in front, the working speed range of the emergency brake assist is 8~90 km/h.

For moving vehicle targets in front, the working speed range of the emergency brake assist is 8~130 km/h.

When the emergency brake assist function is triggered, the vehicle speed will be reduced by at most 45 km/h to mitigate and avoid collision. For example: If the vehicle is traveling at 80 km/h and the emergency brake assist function is triggered, the speed will be reduced to a maximum of 35 km/h, at which point the emergency brake assist will exit.

I. Setting

You can enable or disable the emergency brake assist function by clicking “Vehicle Settings → Assisted Driving → Active Safety → FCW” on the central control screen.

- Select “Not enable” or “Warning” to turn off the emergency brake assist function.
- Select “Warning + Braking” to enable the emergency brake assist function.

Warning

- When the emergency brake assist function is disabled, if there is a greater risk of collision, the vehicle will not take autonomous braking measures. It is recommended that you do not turn off this function.
- When the emergency brake assist function is triggered, the brake pedal will move down quickly. Do not place objects under the brake pedal, as this will affect its movement and thus affect its use.
- The emergency brake assist function is designed only to mitigate or avoid frontal collisions. When the vehicle is not in the D gear, the emergency brake assist function will not work.

Caution

- The emergency brake assist function is enabled by default each time the vehicle is powered on.
- When the emergency brake assist function is activated, a text pop-up and a strong audible alarm will be sent on the instrument panel, and emergency braking measures will be taken simultaneously.
- During the activation of emergency brake assist, the driver can simultaneously depress the brake pedal, and the function will not disengage. However, if the driver releases the brake pedal, it will

7 Driving

be judged as the driver perceiving the danger to have lifted, and the emergency brake assist function will disengage at that point.

II. Function limitation

The emergency brake assist function may have limited performance or may not work in the following scenarios:

- In a curve with a large curvature.
- Outside the speed range for which the emergency brake assist function is designed to operate.
- Uphill or downhill roads or bumpy roads.

Camera perception-restricted scenarios, including but not limited to:

- Dim lighting conditions causing a decrease in recognition capabilities, such as at night, in the shade, during twilight, in tunnels, or in areas where shadows are cast on the road.
- The camera being obstructed or dirty.
- The camera's installation position being changed or loose, resulting in angle deviation.
- Strong light, backlight, reflection and abrupt changes in brightness, such as direct sunlight during the day, especially in summer, flashlights in the surrounding environment, road surface water reflection, entering or exiting tunnels.
- Extreme weather conditions such as high temperature, severe cold, causing the camera's performance to decline.
- Dust, water vapor, water droplets, dirt, or ice on the windshield in front of the camera, obstructing the camera's field of view.
- Severe weather conditions, such as rain, snow, fog, smog, sandstorms, etc.

Millimeter-wave radar perception-restricted scenarios, including but not limited to the following situations:

- The radar's installation position being changed or loose, resulting in angle deviation.
- The radar being obstructed by mud, ice, metal objects, etc.
- Extreme weather conditions such as high temperature, severe cold, causing the radar's perception capabilities to decline.
- Vehicle collisions causing the radar's installation position area to be hit or the vehicle surface to be deformed.
- Electromagnetic field interference in the surrounding environment, such as heavy fog, rain, snow, or sandstorms.
- Due to the limitation of the characteristics of radar electromagnetic waves, there may be misidentification in some special scenarios, such as metal guardrail, green belt, cement wall, construction area, etc.

Only standard vehicle targets will be recognized and responded to. The following target scenarios may not be recognized and braked, including but not limited to:

- Horizontal vehicle target.
- Pedestrians or two-wheeled, three-wheeled, and other motorized vehicles.
- Road obstacles, such as water horses, stone pillars, crash cushions, cones, posts, triangular warning signs, etc.
- Vehicles driving across or in the opposite direction.
- Non-vehicle targets such as fences, traffic lights, road signs, barrier poles, walls, animals, etc.
- Special vehicle targets such as construction vehicles, engineering vehicles, heterogeneous vehicles, etc.

If the relative speed between your car and the vehicle in front is too high, the emergency brake assist function may not be able to recognize or brake:

- The vehicle ahead is stationary or moving slowly, especially at night or during uphill or downhill driving, where recognition may be delayed.
- The vehicle ahead suddenly brakes.
- A vehicle in an adjacent lane cuts into the path ahead of your vehicle.
- Your vehicle suddenly cuts into the path behind the vehicle in front.

Warning

- The emergency brake assist is a driving assist function. When encountering a collision risk, it will take braking measures autonomously, but it may not be able to completely avoid collisions. Therefore, the driver needs to remain attentive to the road and traffic, and take over the vehicle in time when encountering danger.
- The above warnings and limitations do not cover all possible situations that may affect the normal operation of the emergency brake assist function. During use, various factors may interfere with the function's operation. To avoid safety incidents, please stay focused and always pay attention to the traffic environment, road conditions and vehicle status.
- The emergency brake assist function is not intended to maintain a safe following distance from the vehicle in front. Please avoid driving too closely to the vehicle in front or engaging in intense driving behaviors.
- The driver has the highest control over the vehicle. When the driver performs the following operations, it may result in the emergency brake assist function not triggering or the braking interruption, including but not limited to:
 - The driver releases the brake pedal during the emergency brake assist activation process.
 - The driver heavily or suddenly depresses the accelerator pedal.
 - The driver sharply turns the steering wheel.

7 Driving

- The driver unbuckles the safety belt.
- The driver shifts to a non-D gear.

7.6.14 ELK

Emergency lane keeping assist (ELK). When the driver unintentionally deviates from the lane or is about to change lanes by turning on the turn signal light, and if there is a collision risk with an oncoming vehicle in the opposite direction of the adjacent lane, or a vehicle from behind in the same direction, or a risk of collision with the curb, the system will apply steering torque in real-time to correct the driving trajectory, keeping the vehicle centered in the current lane to reduce the collision risk.

I. Setting

Click “Vehicle Settings → Assisted Driving → Driving Assist → LDA” through the central control screen, and click the “Correction” option below the LDA, to enable the ELK function.

II. Function activation

ELK function will be activated when the following conditions are met:

- The vehicle speed is between 60km/h and 130km/h.
- The function is enabled.
- Collision risk of vehicles: There is a risk of collision with the low curb outside the lane. When a vehicle changes lanes or deviates from its lane, there is a risk of collision with vehicles in the adjacent lanes behind it. When a vehicle deviates from its lane, there is a risk of collision with oncoming vehicles or low-speed vehicles ahead.

When there is a risk of lateral collision, the vehicle will issue image and sound alerts and perform lateral control to correct the driving trajectory.

Warning

- The ELK function cannot control the direction of vehicle travel, that is, it cannot continuously keep the vehicle within the lane.
- This function cannot prevent collisions in all situations. In case of dangerous situations, please take measures to avoid risks in time.

II. Function limitation

Vehicles are traveling on sharp turns, roads with many road joints, and sections with special lane markings (such as deceleration warning lines, diversion lines, variable guidance lane lines, etc.). Vehicles are traveling on roads without lane lines, with unclear lane lines or unclear road divisions, such as non-standardized roads, intersections, construction areas, intersections where lane lines converge or separate, etc.

The camera’s imaging capabilities may be affected, including but not limited to the following:

- Poor visibility due to nighttime.
- Poor visibility due to severe weather conditions (e.g., heavy rain, heavy snow, dense fog, sandstorms, etc.).
- Strong light, backlight, water reflection and extreme light contrast.
- The camera is obstructed by mud, ice, snow, etc.
- Extreme weather conditions such as high temperature, severe cold, causing the camera's performance to decline.

The detection capability of the millimeter wave radar may be affected, including but not limited to:

- The radar is affected by the surrounding environment (e.g., electromagnetic field interference, underground parking lots, tunnels, railways, construction areas, width and height restrictions).
- The radar is obstructed by mud, ice, snow, etc.
- Extreme weather conditions such as high temperature, severe cold, causing the radar's performance to decline.

Warning

- The ELK is a driving assist function and cannot cope with all traffic, weather and road conditions. The driver should still pay attention to the vehicle ahead in real time, maintain an appropriate distance, control the speed, brake in time, hold the steering wheel, and be prepared to take over the vehicle at any time.

7 Driving

7.6.15 Rearward emergency brake assist

Rearward emergency brake assist (REBA). When the vehicle speed is less than 10 km/h and the vehicle is in the R gear, if the system detects that there are stationary vehicles, stationary pedestrians or pillars with collision risk, it will automatically take emergency braking measures.

I. Setting

You can turn on the early warning + braking function by clicking "Vehicle Settings → Intelligent Driving → Active Safety → Rear Collision Warning" through the central control screen.

II. Function activation

The rear collision warning function will be activated when the following conditions are met:

- The vehicle speed is between 0km/h and 10km/h.
- The vehicle is driving rearward.
- The driver's seat belt is fastened.
- There is a risk of collision at the rear.

Hint

- When the function is activated, the system will issue an image and sound reminder. After the prompt, the driver should control the vehicle as soon as possible to prevent collisions.
- When the system is triggered to work, the function will be suppressed and exited when the driver press the accelerator pedal or the brake pedal.

III. Function limitation

Camera perception-restricted scenarios, including but not limited to:

- Dim lighting conditions causing a decrease in recognition capabilities, such as at night, in the shade, during twilight, in tunnels, or in areas where shadows are cast on the road.
- The camera being obstructed or dirty.
- The camera's installation position being changed or loose, resulting in angle deviation.
- Strong light, backlight, reflection and abrupt changes in brightness, such as direct sunlight during the day, especially in summer, flashlights in the surrounding environment, road surface water reflection, entering or exiting tunnels.
- Extreme weather conditions such as high temperature, severe cold, causing the camera's performance to decline.
- Dust, water vapor, water droplets, dirt, or ice on the windshield in front of the camera, obstructing the camera's field of view.
- Severe weather conditions, such as rain, snow, fog, smog, sandstorms, etc.

Millimeter-wave radar perception-restricted scenarios, including but not limited to the following situations:

- The radar's installation position being changed or loose, resulting in angle deviation.
- The radar being obstructed by mud, ice, metal objects, etc.
- Extreme weather conditions such as high temperature, severe cold, causing the radar's perception capabilities to decline.
- Vehicle collisions causing the radar's installation position area to be hit or the vehicle surface to be deformed.
- Electromagnetic field interference in the surrounding environment, such as heavy fog, rain, snow, or sandstorms.
- Due to the limitation of the characteristics of radar electromagnetic waves, there may be misidentification in some special scenarios, such as metal guardrail, green belt, cement wall, construction area, etc.

Warning

- The REBA function is a driving assist function. This function cannot replace the driver's observation and judgment of traffic conditions, as well as the driver's responsibility for driving the vehicle safely.

7 Driving

7.6.16 FCW

Forward collision warning (FCW). If you judges that there is a collision risk between your vehicle and the vehicle in front, FCW will send visual, auditory and tactile alarm information to remind the driver. The alarm will automatically cancel when the collision risk disappears. The working speed range of the FCW function is 8~130 km/h.

Caution

- The forward collision warning function only works for standard vehicles. Some vehicles with irregular shapes or abnormal structures, or those with excessive loading, may not be recognized by the system.

I. Setting

You can enable or disable the FCW by clicking on the options under “Vehicle Settings → Assisted Driving → Active Safety → FCW” through the central control screen.

- Select “Not enable” to turn off FCW.
- Select “Warning” or “Warning + Braking” to enable FCW.

If an alarm sensitivity adjustment is equipped, the optional alarm sensitivity can be divided into "late", "moderate" and "early".

Caution

- FCW is set to be enabled by default each time the vehicle is powered on.
- When selecting the warning function, the system will only send warning prompts in a dangerous situation and will not take braking measures.

Hint

- When FCW is triggered, a text pop-up + strong sound alarm prompt will appear on the instrument panel. When the situation is more dangerous, there will also be accompanied by tactile alarms such as steering wheel vibration and light braking.

II. Function limitation

FCW may have limited performance or may not work in the following scenarios:

- In a curve with a large curvature.
- Outside the speed range for which the forward collision warning function is designed to operate.
- Uphill or downhill roads or bumpy roads.

Camera perception-restricted scenarios, including but not limited to:

- Dim lighting conditions causing a decrease in recognition capabilities, such as at night, in the shade, during twilight, in tunnels, or in areas where shadows are cast on the road.
- The camera being obstructed or dirty.
- The camera's installation position being changed or loose, resulting in angle deviation.
- Strong light, backlight, reflection and abrupt changes in brightness, such as direct sunlight during the day, especially in summer, flashlights in the surrounding environment, road surface water reflection, entering or exiting tunnels.
- Extreme weather conditions such as high temperature, severe cold, causing the camera's performance to decline.
- Dust, water vapor, water droplets, dirt, or ice on the windshield in front of the camera, obstructing the camera's field of view.
- Severe weather conditions, such as rain, snow, fog, smog, sandstorms, etc.

Millimeter-wave radar perception-restricted scenarios, including but not limited to the following situations:

- The radar's installation position being changed or loose, resulting in angle deviation.
- The radar being obstructed by mud, ice, metal objects, etc.
- Extreme weather conditions such as high temperature, severe cold, causing the radar's perception capabilities to decline.
- Vehicle collisions causing the radar's installation position area to be hit or the vehicle surface to be deformed.
- Electromagnetic field interference in the surrounding environment, such as heavy fog, rain, snow, or sandstorms.
- Due to the limitation of the characteristics of radar electromagnetic waves, there may be misidentification in some special scenarios, such as metal guardrail, green belt, cement wall, construction area, etc.

Only standard vehicle targets will be recognized and responded to. The following target scenarios cannot be recognized, including but not limited to:

- Horizontal vehicle target.
- Pedestrians or two-wheeled, three-wheeled, and other motorized vehicles.
- Road obstacles, such as water horses, stone pillars, crash cushions, cones, posts, triangular warning signs, etc.
- Vehicles driving across or in the opposite direction.
- Non-vehicle targets such as fences, traffic lights, road signs, barrier poles, walls, animals, etc.
- Special vehicle targets such as construction vehicles, engineering vehicles, heterogeneous vehicles, etc.

7 Driving

In the following situations, if the relative speed to the vehicle in front is too high, FCW may not be able to recognize or send a warning:

- The vehicle ahead is stationary or moving slowly, especially at night or during uphill or downhill driving, where recognition may be delayed.
- The vehicle ahead suddenly brakes.
- A vehicle in an adjacent lane cuts into the path ahead of your vehicle.
- Your vehicle suddenly cuts into the path behind the vehicle in front.

Warning

- FCW is a driving assist alarm function. This function cannot replace the driver's monitoring of dangerous targets on the road. Please do not rely too much on this function.
- The above warnings and limitations do not cover all possible situations that may affect the normal operation of FCW. During use, various factors may interfere with the function's operation. To avoid safety incidents, please stay focused and always pay attention to the traffic environment, road conditions and vehicle status.
- The driver has the highest control over the vehicle. When the driver performs the following operations, it may result in FCW not sending an alarm or the alarm being interrupted, including but not limited to:
 - The driver depresses the brake pedal.
 - The driver heavily or suddenly depresses the accelerator pedal.
 - The driver sharply turns the steering wheel.
 - The driver unbuckles the safety belt.
 - The driver shifts to a non-D gear.

7.7 Brake system

7.7.1 Electronic handbrake (EPB)

I. Activating or deactivating the electronic handbrake

Activation: When the vehicle is stationary, activate the electronic handbrake by clicking “Vehicle Settings → Vehicle → Driving → Electronic Handbrake” through the central control screen or pressing the P gear button. At this time, the electronic handbrake brake indicator on the instrument panel illuminates.

Deactivation: When the vehicle is stationary, depress the brake pedal, and deactivate the electronic handbrake by clicking “Vehicle Settings → Vehicle → Driving → Electronic Handbrake” through the central control screen or shifting the gear to D or R. At this time, the electronic handbrake brake indicator on the instrument panel turns off.

Hint

- It is normal that a certain amount of noise will be generated when the electronic handbrake is working.

II. Autohold activation

When the following conditions are met, depress the brake pedal, and the vehicle decelerates to a stop. Deeply depress the brake pedal to activate the Autohold function:

- The vehicle power supply is in "READY" mode.
- The driver's side door is closed.
- The driver's seatbelt is fastened.
- The gear is in D, N or R.
- After Autohold is activated, the Autohold indicator on the instrument panel illuminates, indicating that the vehicle is parked. At this time, you can release the brake pedal.

III. Autohold deactivation

After Autohold is activated, depress the accelerator pedal or brake pedal when starting to deactivate Autohold.

For safety reasons, Autohold will be forcibly deactivated and the electronic handbrake will be automatically activated in the following situations:

- The vehicle power is in “OFF” or “ON” mode.
- The gear is shifted to P.
- The driver's side door is open.
- Autohold has been working for 6 min.
- After Autohold is deactivated, the Autohold indicator on the instrument panel turns off.

7 Driving

Warning

- When the brake system or power supply is faulty, activating Autohold may cause the vehicle to slide. Please drive cautiously based on the road conditions.

IV. Wiping brake disc

Wiping brake disc can remove the water film adhering to the brake disc, ensure the cleanliness of the brake disc, effectively improve the braking effect during emergency braking, shorten the braking distance, and enhance driving safety.

During driving, when the vehicle sensor detects rain or the windshield wiper is activated, the brake disc wiping function is automatically activated. The brake disc wiping is turned off if the wiper is closed or the vehicle speed does not reach the threshold.

7.7.2 Body electronic stability program (ESP)

The electronic stability program (ESP) recognizes the vehicle's driving state through sensors installed on the vehicle. When the vehicle appears understeer, oversteer, or drive slip, ESP will actively adjust the driving torque or apply braking force to reduce the risk of skidding or spinning, thereby ensuring the vehicle's driving safety.

I. Indicator

When ESP is working, the ESP indicator on the instrument panel flashes. When ESP fails, the ESP indicator on the instrument panel remains on. Please drive carefully and contact the ROX Service Center immediately to avoid vehicle damage or accidents.

Warning

- Modifying the vehicle (including the braking system, suspension, steering system, tire structure, wheel and tire size) may change the vehicle's handling characteristics. This may have a negative impact on the performance of ESP.
- ESP cannot exceed the physical limits of road adhesion and cannot prevent accidents caused by dangerous driving or high-speed emergency steering. Please drive cautiously according to road conditions.

7.7.3 Anti-lock brake system (ABS)

The main function of ABS is to adjust the braking pressure on the four wheels of the vehicle during emergency braking to prevent wheel lock-up, ensuring that the vehicle retains steering capability during emergency braking, reducing braking distance, and enhancing vehicle safety.

In normal braking, ABS will not be activated. In emergency braking, ABS is activated, and the driver can feel the brake pedal vibrate. At this time, drive according to the road conditions.

Warning

- The driver must always maintain a safe distance from the vehicle ahead and be aware of potential hazards while driving. ABS can improve braking distance, but it cannot surpass the laws of physics. When there is a layer of water between the tires and the road surface, and the tires cannot directly contact the road, ABS cannot prevent the danger of wheel slip.

Hint

- When ABS is activated, the ABS indicator on the instrument panel flashes, accompanied by ABS working noise, which is a normal phenomenon. If the ABS fault light remains on, please contact the ROX Service Center immediately.

7 Driving

7.7.4 Electronic brake-force distribution (EBD)

The main function of electronic brake-force distribution (EBD) is to automatically adjust the braking force between the front and rear axles of the vehicle when braking causes a shift in axle load, ensuring that the vehicle has the best braking performance.

Hint

- When EBD is working, the EBD indicator flashes. If the EBD fault light remains on, please contact the ROX Service Center immediately.

7.7.5 Traction control system (TCS)

The main function of traction control system (TCS) is to prevent the driving wheels from slipping when the vehicle starts on ice, snow, or wet surfaces, or when the vehicle accelerates sharply. TCS adjusts the vehicle's output torque and controls braking pressure to minimize wheel spin as much as possible, thereby improving vehicle stability and comfort.

Hint

- When TCS is activated, the indicator on the instrument panel flashes. If the vehicle is stuck in mud, deep snow, rocks, sand, or other surfaces and cannot be driven out, the escape function can be activated. TCS will control wheel slip while trying to maintain sufficient driving torque to help the vehicle get out of trouble.

7.7.6 Hydraulic brake assist (HBA)

When the driver rapidly depresses the brake pedal, the hydraulic brake assist (HBA) can recognize that the vehicle is in an emergency state and quickly increase braking pressure to its maximum value, allowing the ABS to intervene more quickly and effectively shorten the braking distance.

Warning

- HBA can enhance driving safety but cannot eliminate the risks caused by following too close, vehicle slip, speeding, or sharp turns. Please drive cautiously.

7.7.7 Roll motion intervention (RMI)

When the vehicle is turning, the roll motion intervention (RMI) detects the vehicle's motion state to judge if there is a risk of rollover. If there is a risk of rollover, RMI will apply braking and deceleration to one or more wheels to prevent the vehicle from rolling over.

Warning

- RMI is an assist function and cannot completely eliminate the risk of rollover. The driver should drive safely to ensure driving safety.

7.7.8 Cornering stability control (CSC)

The cornering stability control (CSC) system can control the braking pressure on the front wheels of the vehicle during cornering braking. This avoids the inner wheels from locking up prematurely, and improves the vehicle's driving stability.

7 Driving

7.7.9 Dynamic parking brake (CDP)

During driving, if an emergency situation such as brake failure occurs, you can press and hold the P gear button to activate the CDP function, and the vehicle will decelerate within a certain range of deceleration values. Release the P gear button, and CDP will immediately exit.

Warning

- Do not use this function under non-emergency conditions to avoid safety accidents during driving.

Hint

- Short pressing the P gear button during driving will not activate the CDP function. During the activation of the CDP function, the electronic handbrake indicator on the instrument panel flashes.

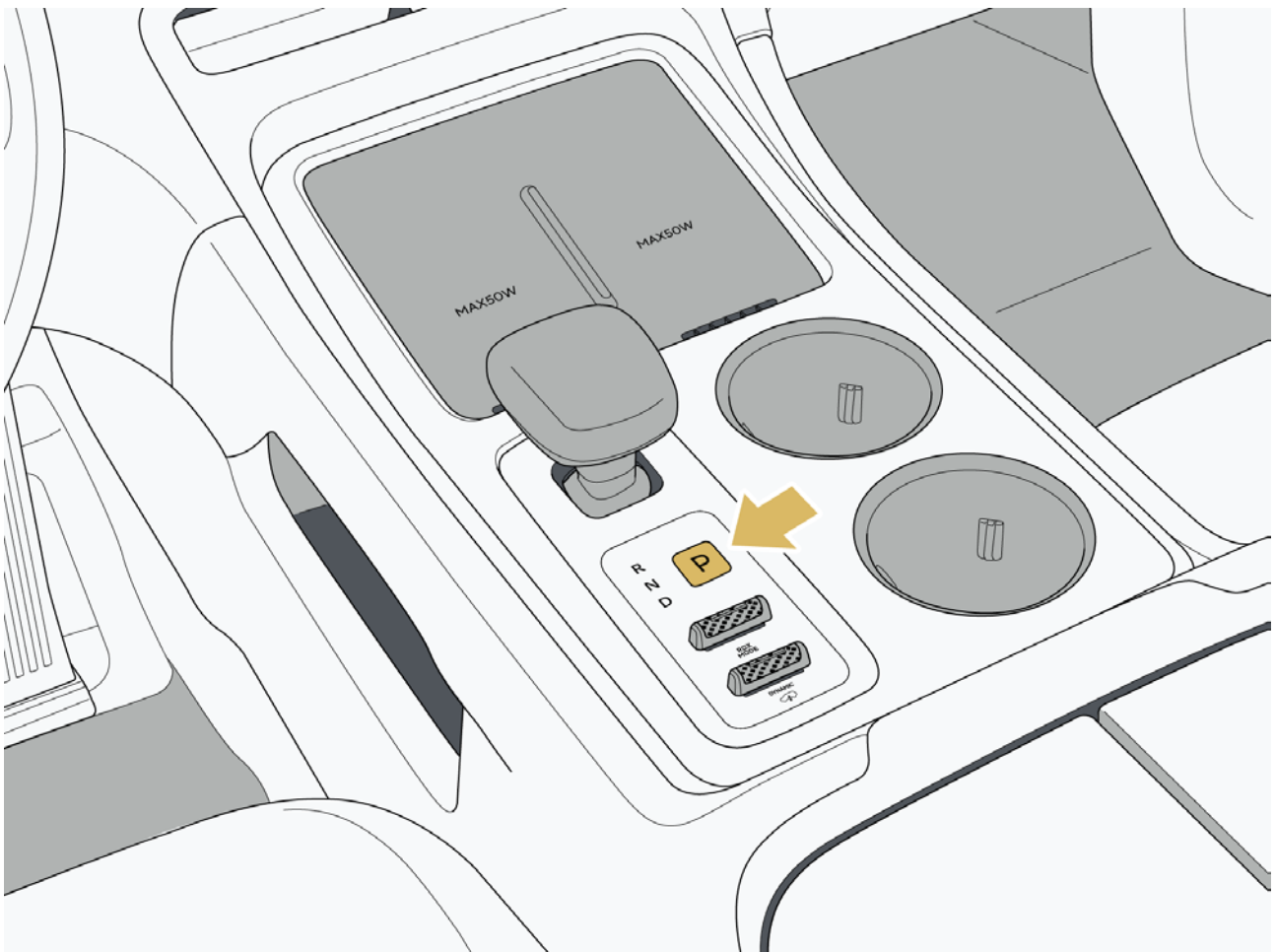

7.7.10 Hill descent control (HDC)

I. Activation/deactivation of HDC

You can activate and deactivate the hill descent control by clicking “ROX → HDC” through the central control screen.

When the vehicle is descending a slope, and the conditions for activating the HDC are met, the system will automatically adjust the vehicle’s output torque or apply a certain braking force to the wheels to ensure a smooth descent.

After HDC is activated, the HDC indicator on the instrument panel illuminates. When HDC is activated during the descent, the HDC indicator on the instrument panel flashes.

Hint

- When the vehicle speed is below 30 km/h, HDC can be enabled. When HDC is enabled. When the vehicle speed is in the range of 5 km/h to 30 km/h, and the vehicle is on a steep slope, HDC is activated. When the vehicle speed is in the range of 30 km/h to 60 km/h, HDC enters a standby state. When the vehicle speed exceeds 60 km/h, HDC is turned off.

7.7.11 Hill start assist (HHC)

When Autohold is not activated, and the vehicle brakes on a slope greater than 5%, the vehicle’s brake system will automatically maintain approximately 1.5 s of braking force. During this 1.5 s, depressing the accelerator pedal will correspondingly reduce the braking force to ensure sufficient time to help the vehicle start.

Warning

- HHC can only prevent the vehicle from sliding downhill for a short time. The driver is responsible for controlling the vehicle, monitoring the system’s operation, and intervening when necessary.

Hint

- HHC can only ensure that releasing the brake pedal produces braking force to keep the vehicle on a slope when the vehicle gear is in D or R.
- HHC can be maintained for about 1.5 s. Avoid park the vehicle with HHC for long periods of time, as this can increase the risk of the vehicle sliding. Please drive cautiously.

7 Driving

7.7.12 Coordinated regenerative braking system (CRBS)

During driving, when the vehicle speed is above 12 km/h and the vehicle brakes, the coordinated regenerative braking system (CRBS) will automatically control the front and rear motors to recover energy. CRBS can both recover energy and provide a certain amount of electric braking force.

You can set the energy recovery level by clicking the “Vehicle Settings → Vehicle → Driving → Energy Recovery” icon through the central control screen. This car provides four levels of recovery: low, medium, high and intelligent. You can set the energy recovery level according to your driving habits.

7.8 Fuel oil and charging

7.8.1 Refuel

I. Before refueling

This vehicle can only be refueled with unleaded gasoline of 95# and above.

II. Open the fuel cap

1. Click the "Fuel filler lock" unlock icon through the central control screen to unlock the tank cap.

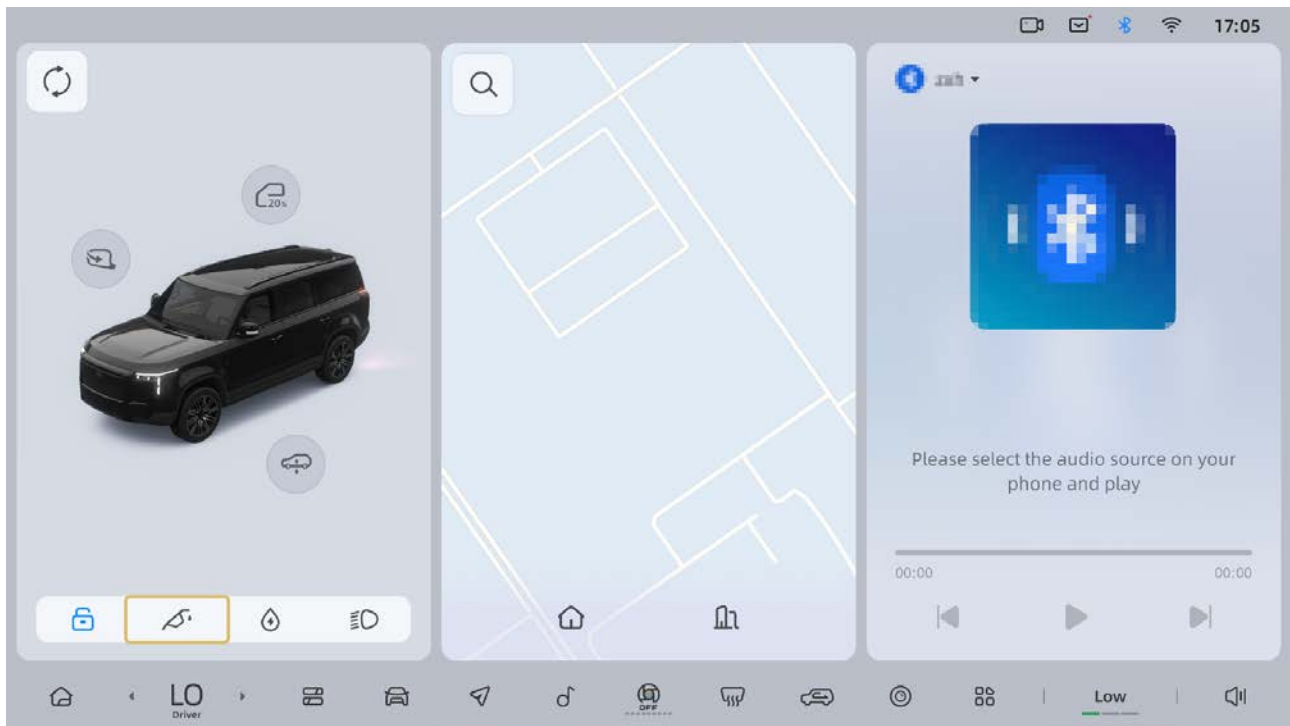

7 Driving

2. Press the edge of the fuel filler cap, and then open the fuel filler cap with your hand.

Hint

- In cold weather, the fuel filler cap may freeze, making it impossible to open. At this time, defrosting treatment should be carried out first.
- Filling the wrong type of fuel can cause damage to the range extender. If you make a wrong fueling, do not start the vehicle. Please contact ROX Service Center in time.

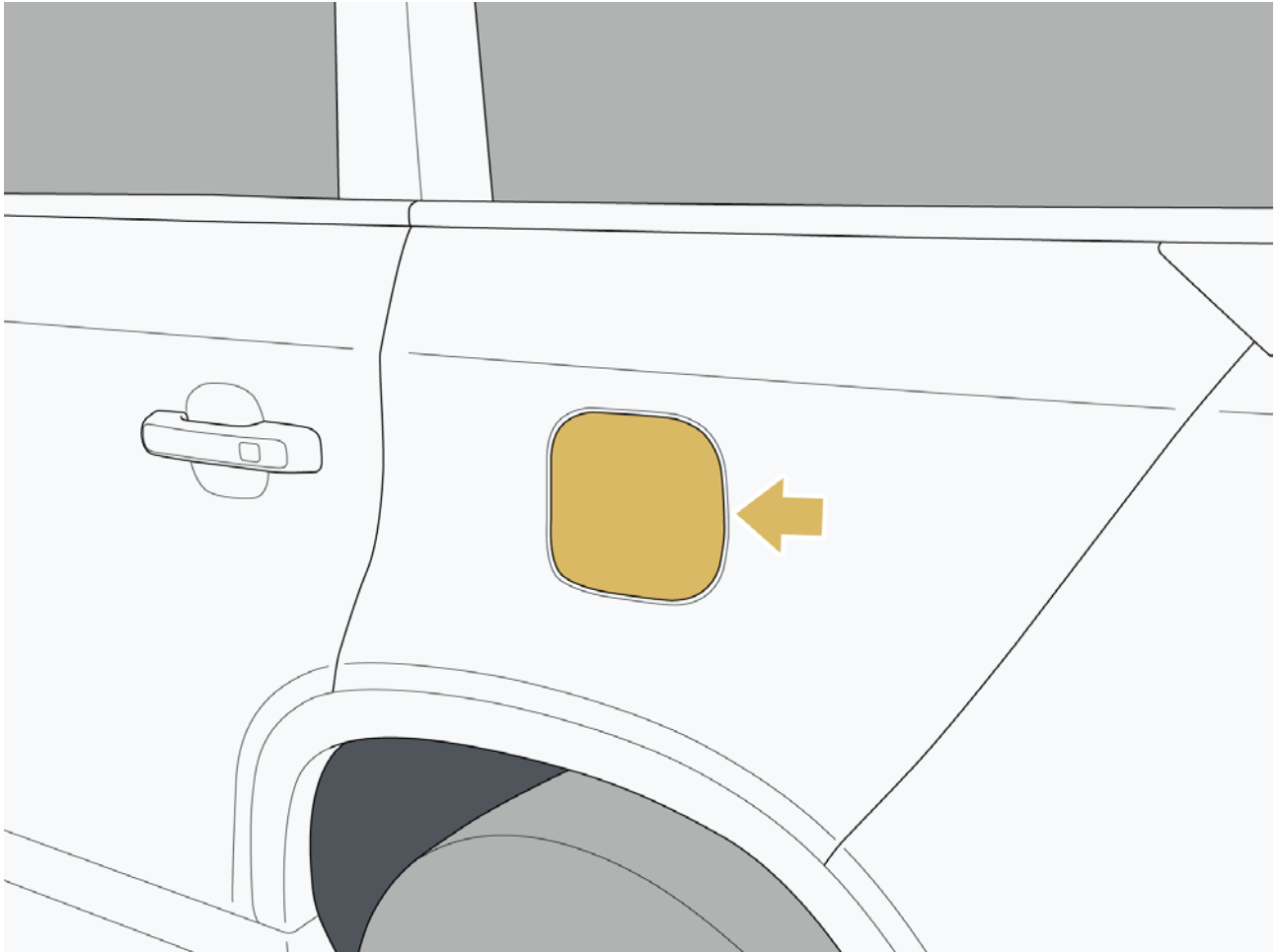

3. Unscrew the tank cap counterclockwise.

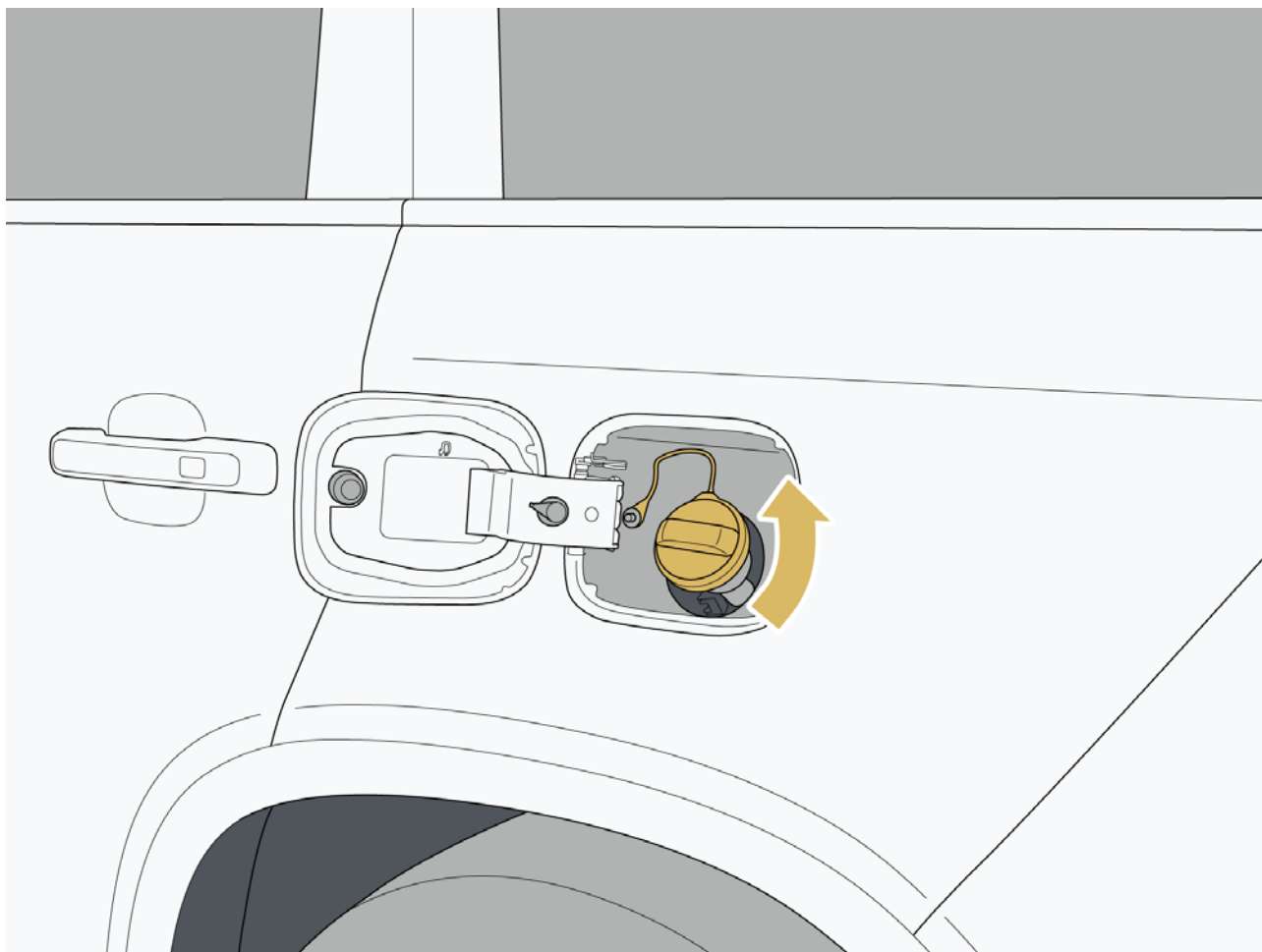

7 Driving

4. Hang the tank cap on the back of the fuel filler cap.

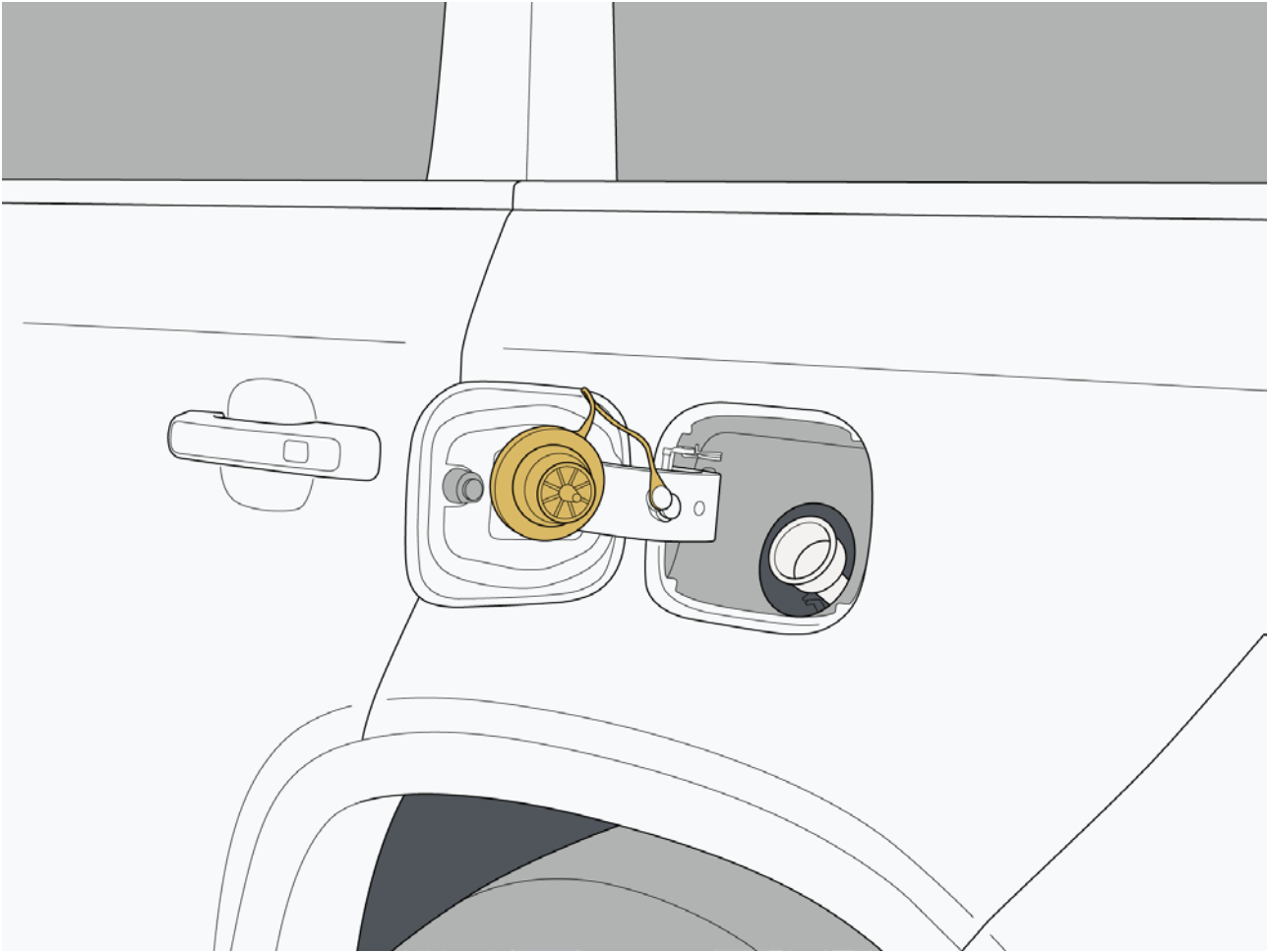

III. Close the tank cap

1. After refueling, rotate the tank cap clockwise until you hear a click, then stop rotating.
2. Close the fuel filler cap until you hear a click.

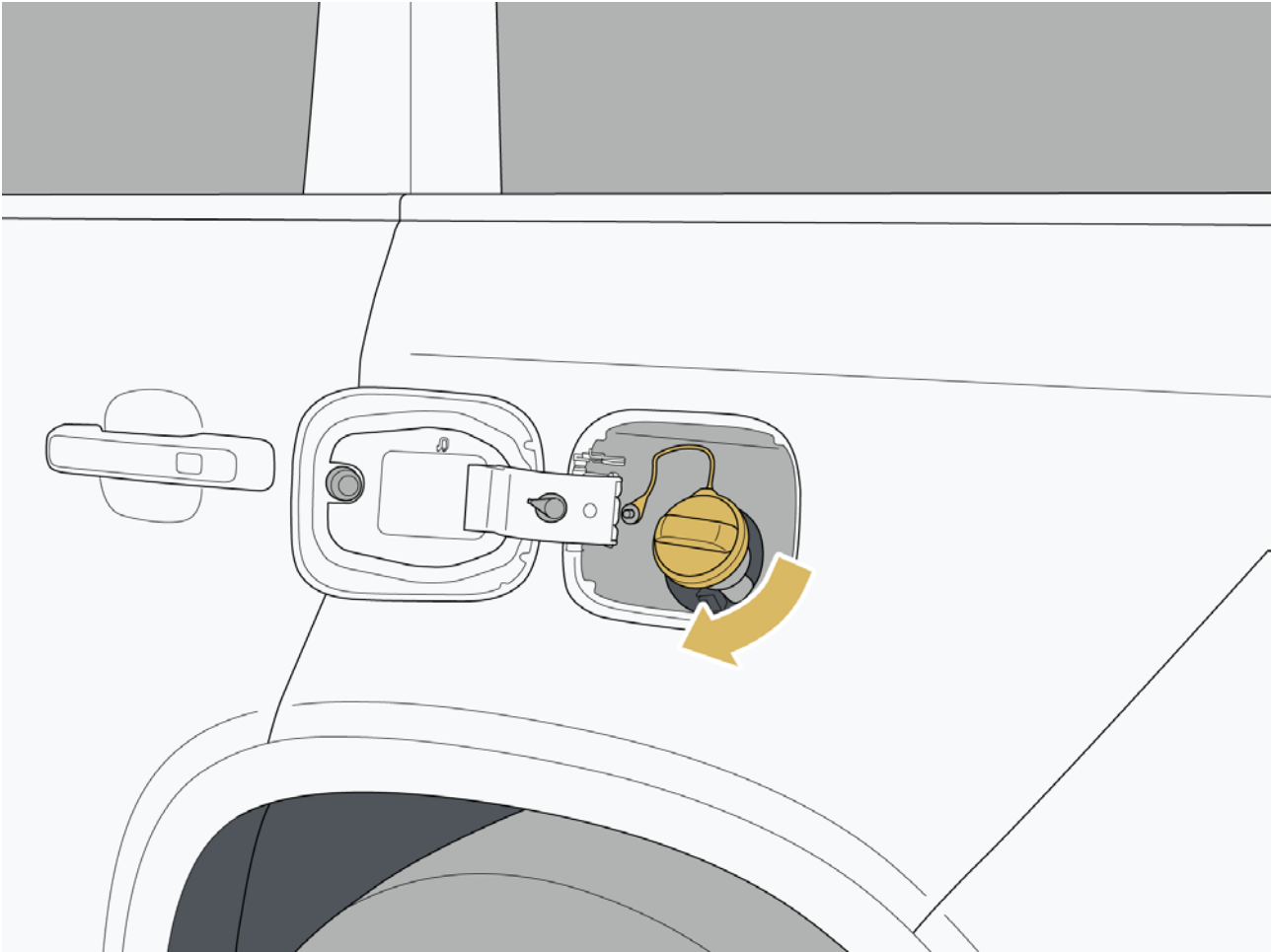

Warning

- Avoid inhaling fuel vapor or splashing fuel on your skin or eyes. Keep children away from fuel.
- Fuel vapor or fuel can burn fiercely when it meets an open fire or spark, which may lead to injury or even death.
- If fuel splashes into your eyes, thoroughly wash your eyes with clean water and seek medical help immediately.
- To avoid personal injury, please read and abide by all the instructions of the gas station.
- Before refueling, please discharge your body's static electricity. Do not allow people who have not released static electricity to approach the fuel nozzle to avoid static electricity accumulation and igniting the fuel.
- Do not smoke; make phone calls while refueling to avoid causing a fire.
- Do not continue to refuel the tank after the fuel nozzle automatically shuts off.

7 Driving

7.8.2 Charging (Configuration 1)

I. Charging port (Configuration 1)

This car is equipped with an AC charging port:

1. Charging port.

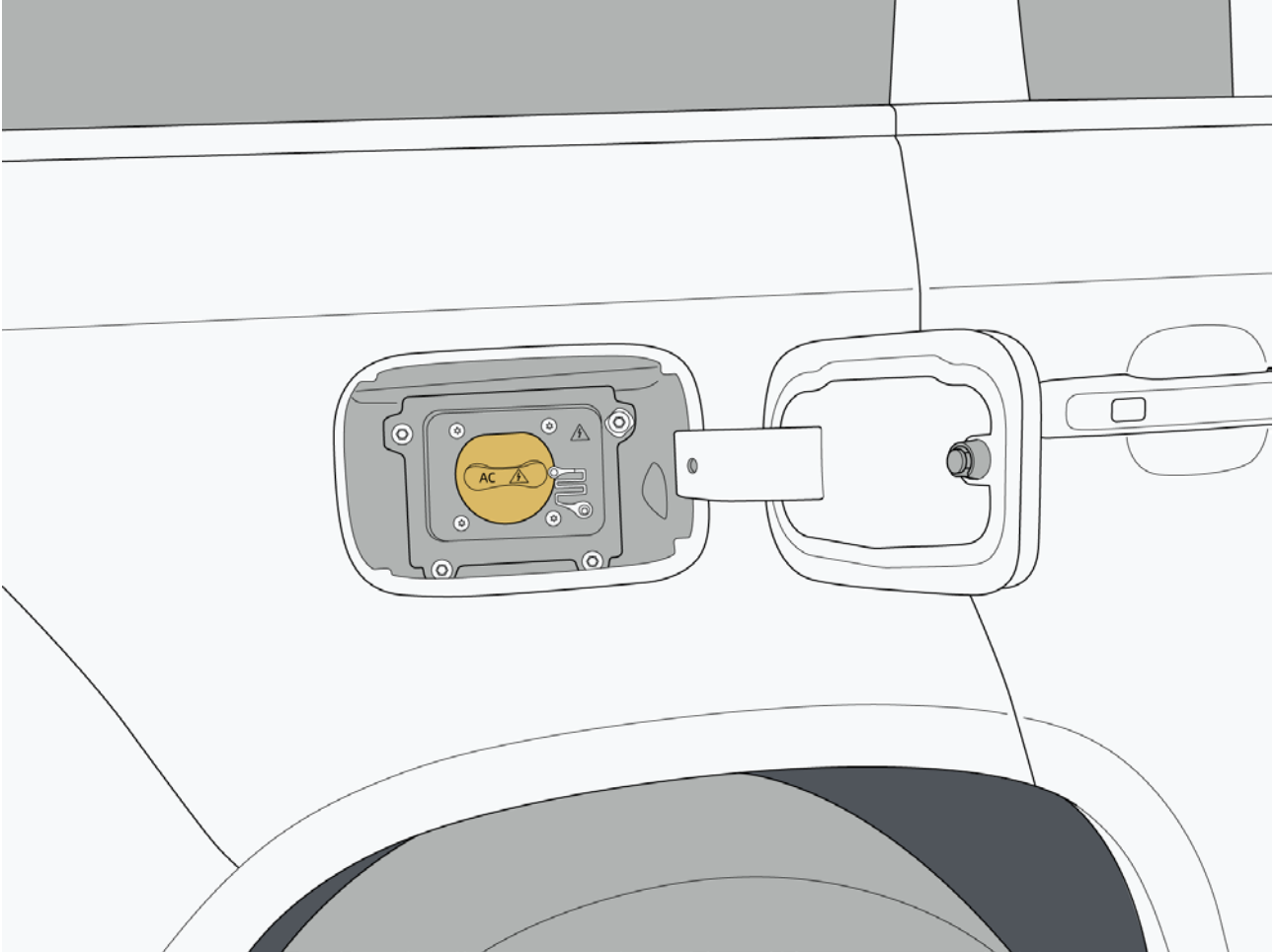

II. Opening and closing the charging port cover

- Opening: When the vehicle is in P gear and unlocked, press the back of the charging port cover to open it.

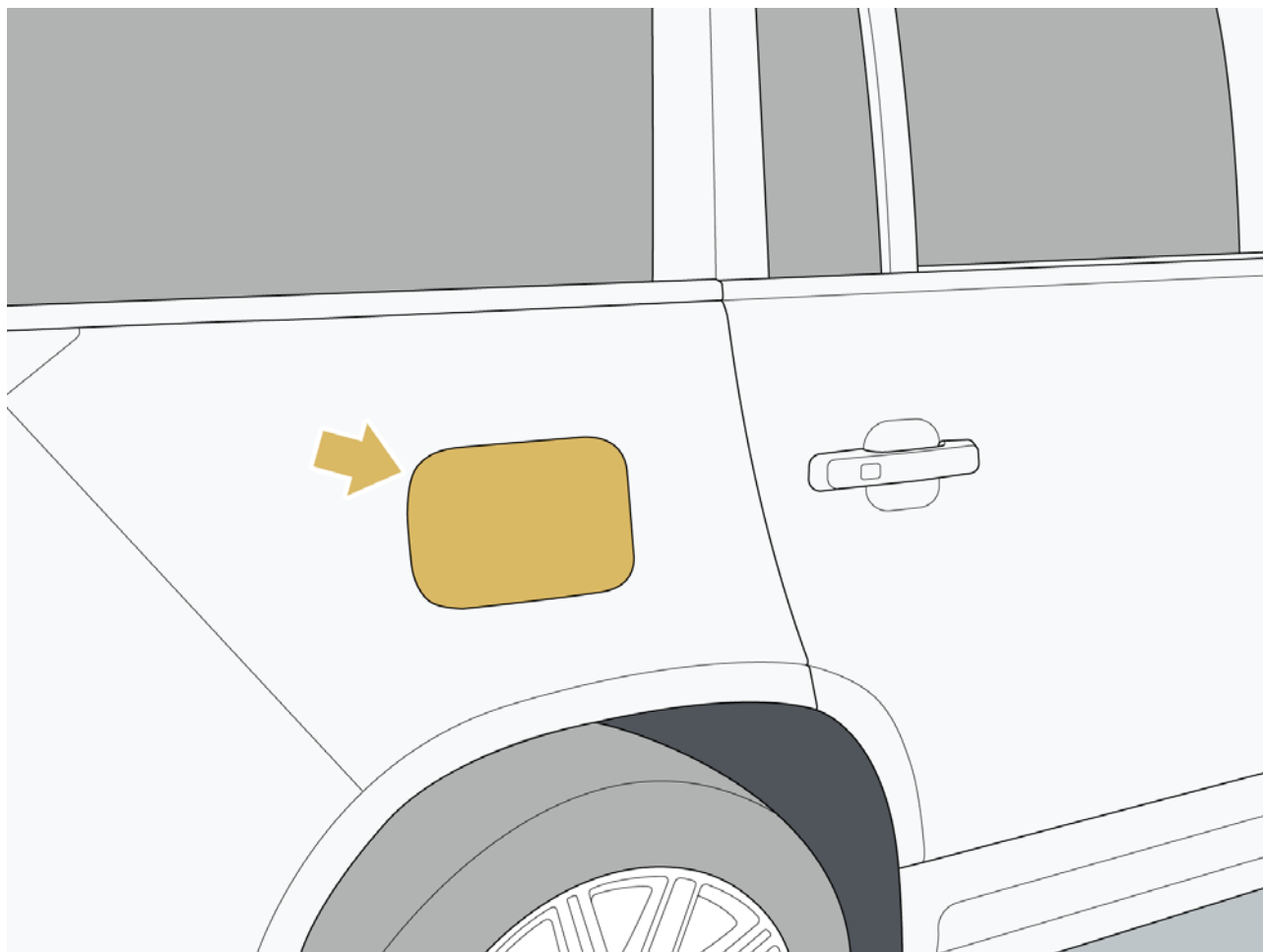

7 Driving

- Closing: After charging, cover the charging port dust cover, gently push the charging port cover until you hear a “click” , and the charging port cover is closed securely.

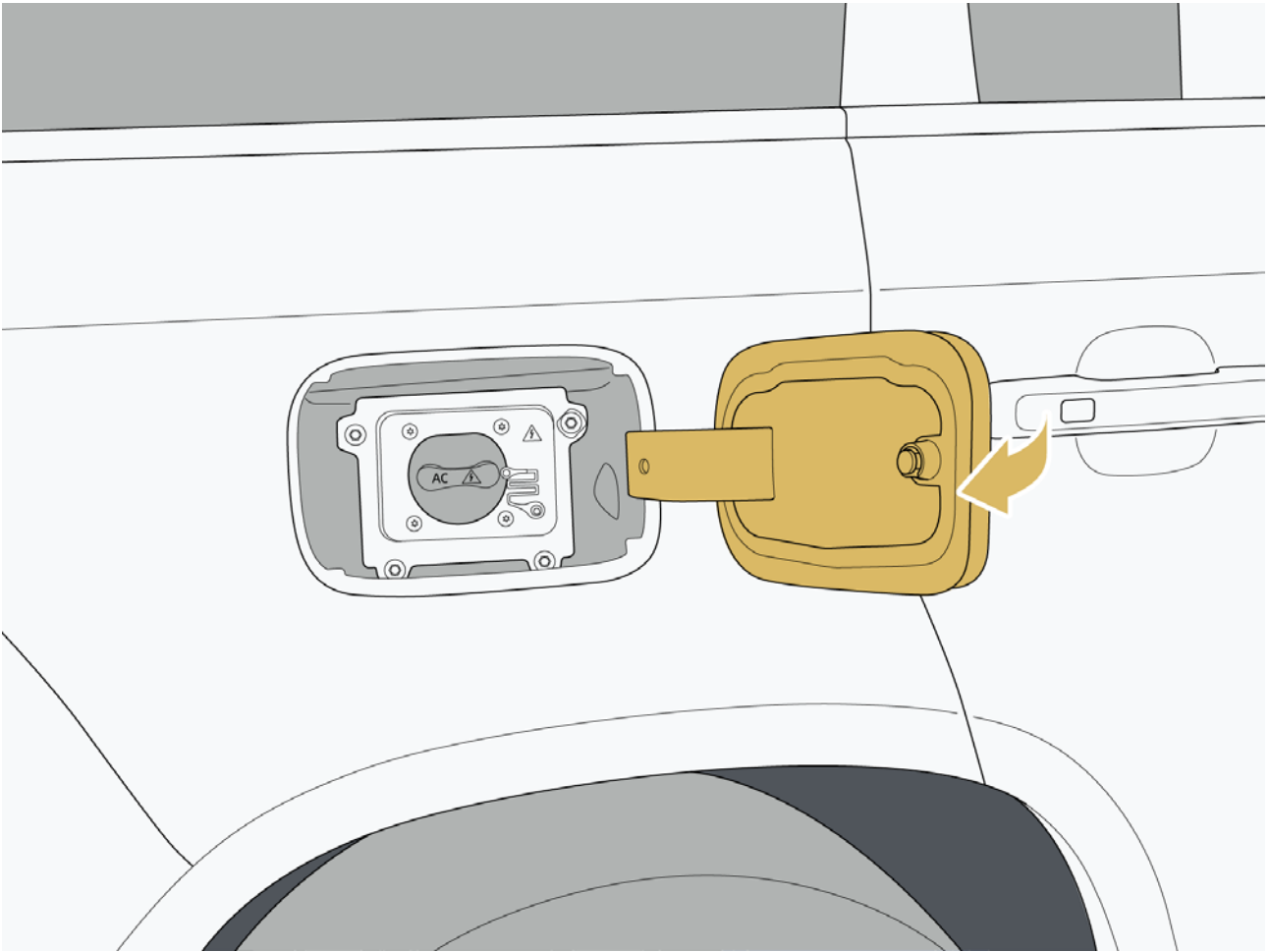

III. Charging operation process

1. Make sure to switch the vehicle to P gear before charging.
2. Open the charging port cover, and remove the charging port dust cover as needed.

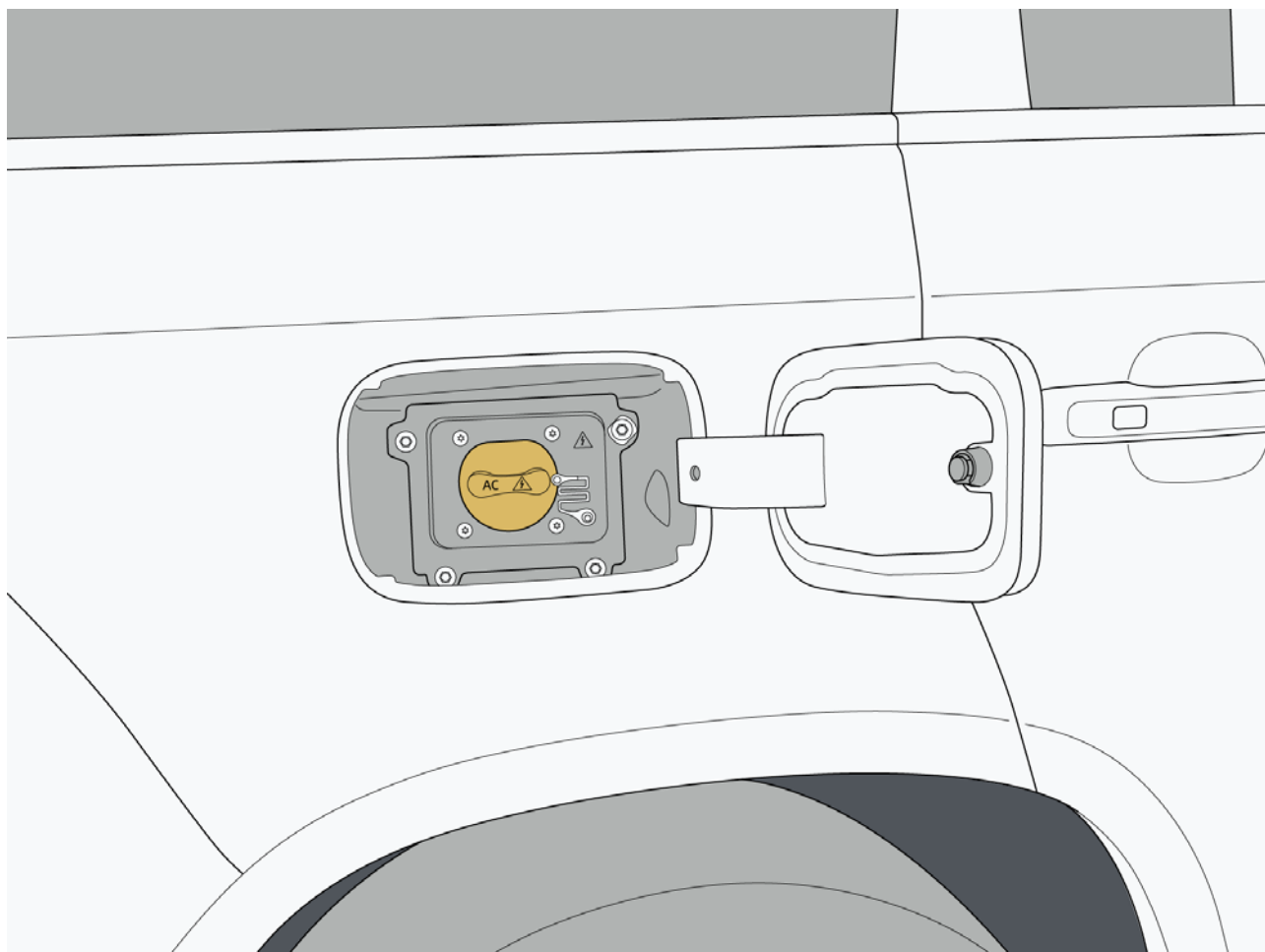

7 Driving

- 3. Before inserting the charger, please familiarize yourself with the charging equipment operation guide and check if the charging equipment is intact, then connect the charger to the charging port. After the charger is connected, you can view the charging status through the central control screen.
- Common charging prompts on the central control screen:

Successful connection.

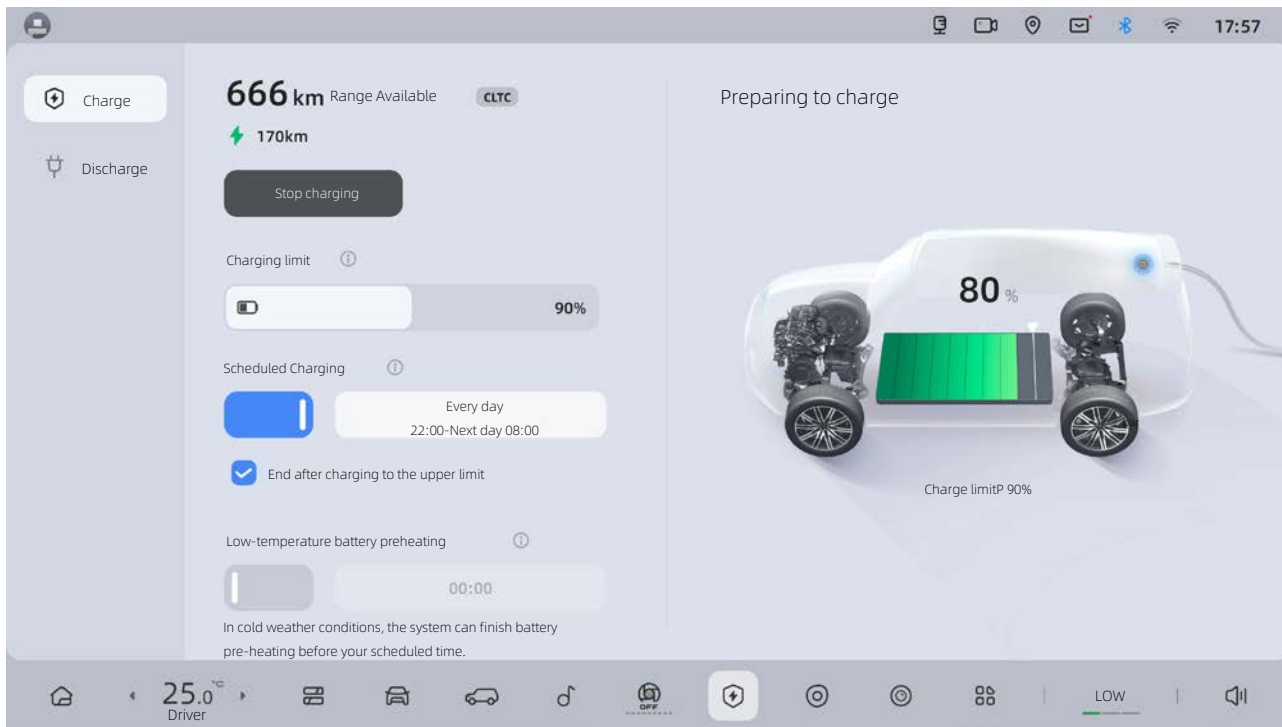

Charging

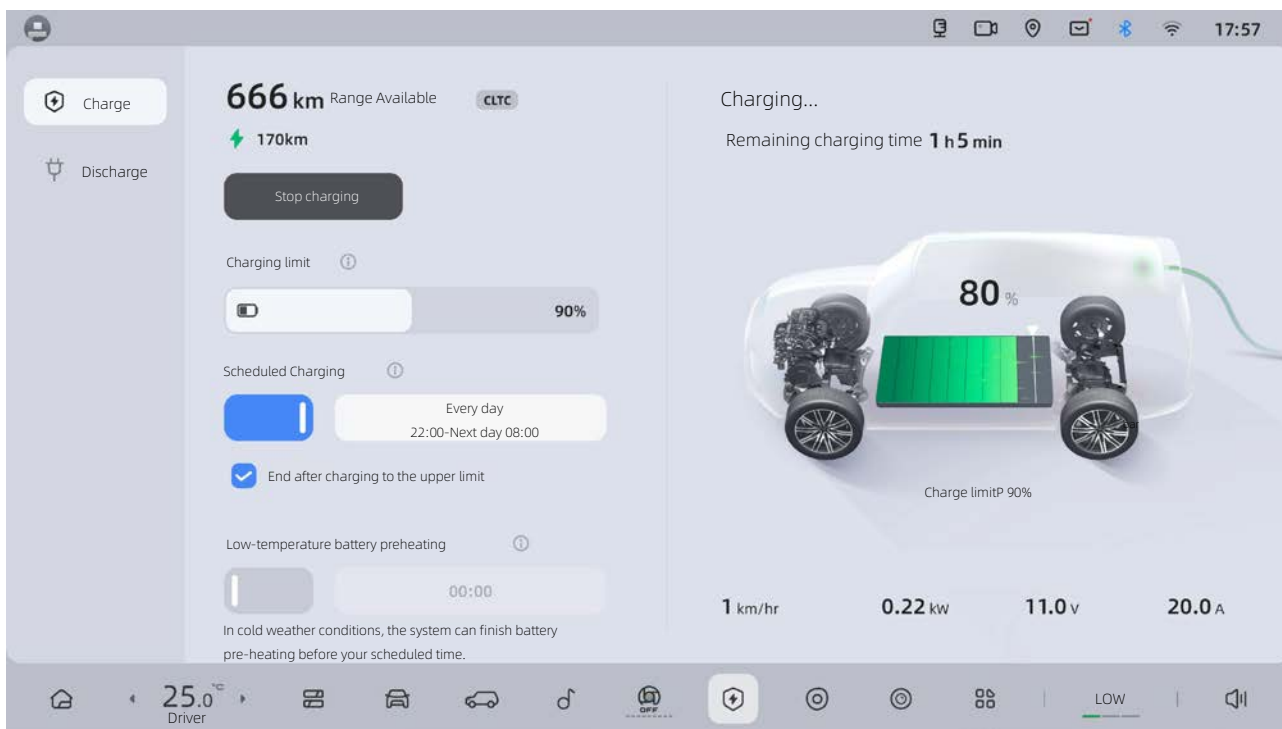

End of charge

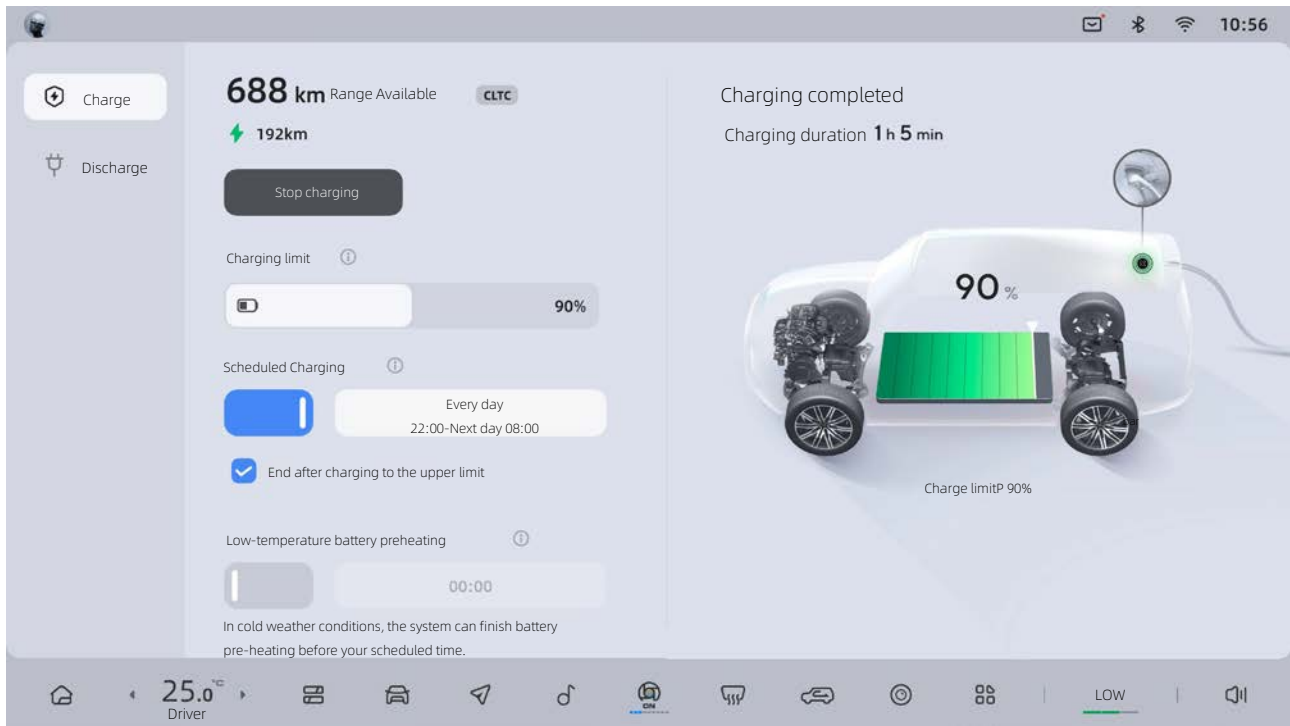

IV. Low temperature battery preheating

When using a car in cold weather, reserving battery heating in advance will effectively increase battery life.

In the charging management interface, click "Low-temperature Battery Preheating" and set the battery preheating completion time.

V. Parking power generation

When the vehicle power is low, use the parking power generation function. The range extender is started to charge the battery.

Click "Parking Power Generation" through the charging control interface to turn on or off the parking power generation function. When using the parking power generation function, the following requirements must be met:

- The vehicle is in P gear.
- The battery level is less than 80%.
- The charger is not inserted.
- The front engine compartment is closed.
- Non exhibition mode.
- The range extender is not disabled (such as when the trailer mode is enabled).

When using the parking power generation function, it can be turned off manually. Or it can be turned off automatically in any of the following situations:

- The charger is connected.

7 Driving

- The vehicle is not in P gear.
- The battery level has reached 80%.
- The vehicle is locked.
- It enters exhibition mode.

Caution

- When using parking power generation, please park the vehicle in a safe area to avoid safety accidents.

VI. Remove the charger

Unplug the charger:

- After charging is complete, the vehicle will automatically unlock the charger, and it can be unplugged directly.
- If you need to stop charging during the charging process, you need to click “Stop Charging” in the charging management interface or unlock the charger by pressing the remote key unlocking button.

VII. Charging setting

1. Reservation charging: In the charging management interface, click “Reservation Charging” to enable or disable reservation charging. When reservation charging is enabled, click the option under the “Reserved Time” to set the start time for reservation charging.
2. Charging limit: In the charging management interface, slide the slider under “Charging Limit” to set the charging limit for the power battery (setting range: 80% ~ 100%).
3. Stop charging: In the charging management interface, click the “Stop Charging” icon to stop charging.
4. Start charging: In the charging management interface, click the “Start Charging” icon to start charging.

VIII. Charging information

If using a 7 kW AC charging station, the battery can be fully charged in about 8 h and 30 min. If using a 11 kW AC charging station, the battery can be fully charged in about 6 h.

IX. Charger locking/unlocking

The locking/unlocking strategy of the electronic lock must meet the requirements of relevant standards. When the charger is inserted into the charging port, the charging port locks the charger with an electronic locking device (electronic lock) to ensure charging safety.

1. Automatic locking/unlocking

During charging, the electronic lock automatically locks.

After charging is complete, the electronic lock automatically unlocks.

If you need to remove the charger during charging or while waiting for scheduled charging, please first unlock the vehicle and remove the charger within 30 s. Otherwise, the electronic lock on the charging port will be re-locked.

2. Emergency unlock

If the electronic lock fails and cannot unlock the charging port, unlock it by pulling the emergency unlock handle.

1. Open the trunk door and remove the luggage compartment mat.
2. After removing the luggage compartment mat, take out the toolbox from the trunk and pull the emergency unlock handle to unlock the electronic lock of the charging port.

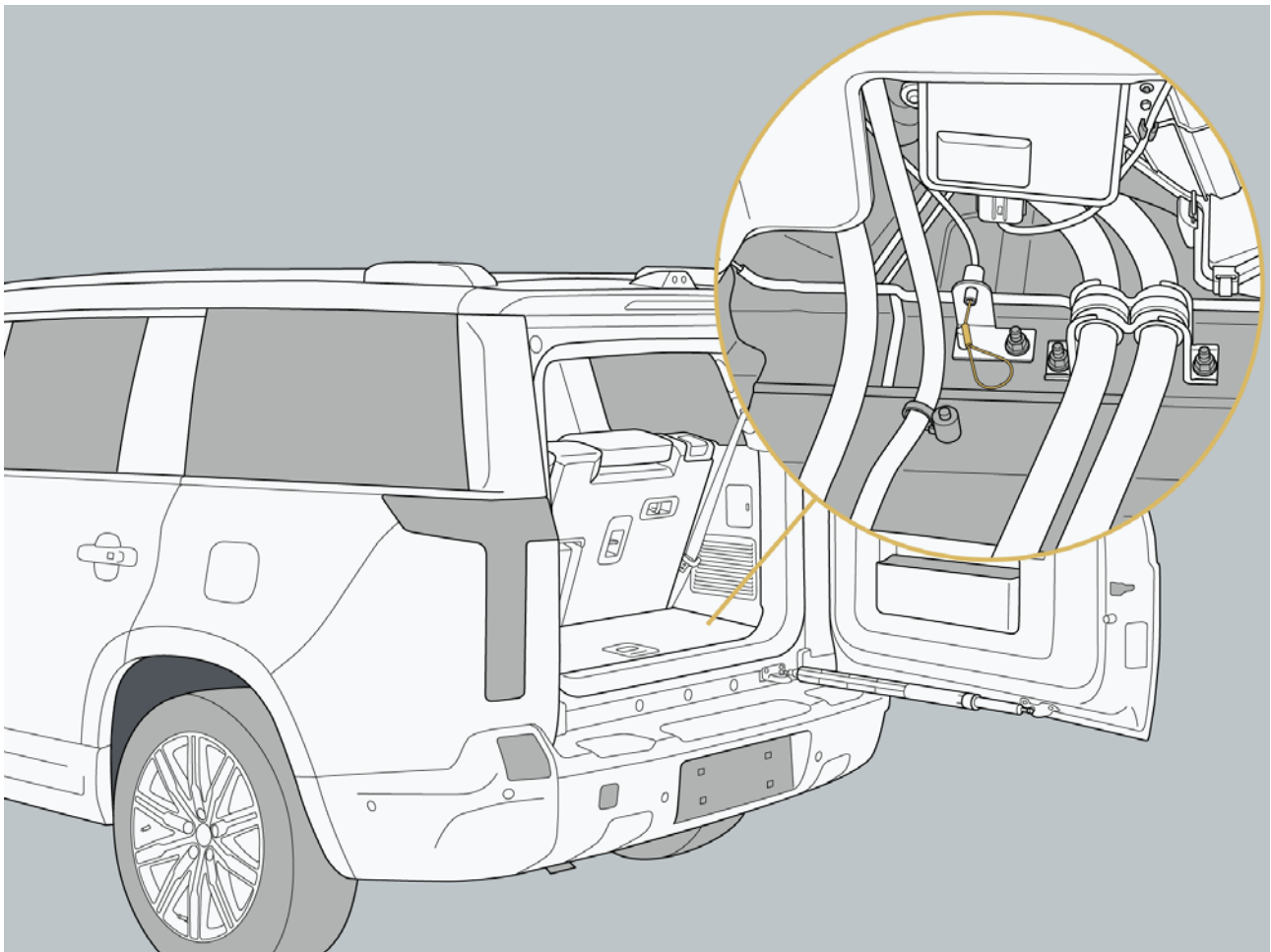

7 Driving

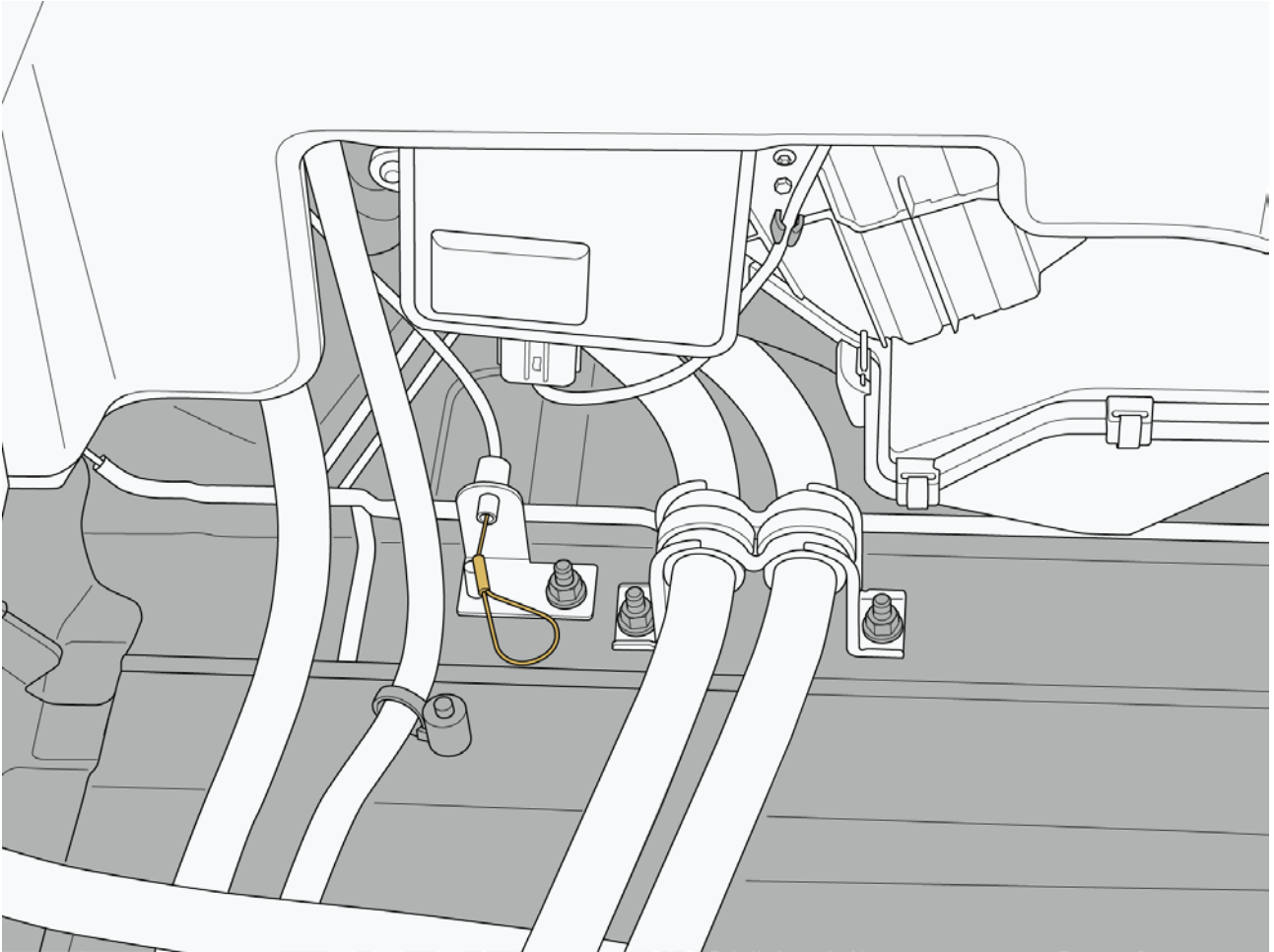

Warning

- If the pure electric range displayed on the instrument panel drops to 0, it must be charged within 24 h. If it is not charged within 7 days, it may cause permanent damage to the battery. If the vehicle cannot be charged, please contact the ROX Service Center immediately.
- Do not charge when the charging equipment is damaged, rusted, damp, or has foreign objects, to avoid electric shock.
- Do not wash the charging port area while charging, to avoid damage to the vehicle or charging equipment.
- Do not forcefully pull out the plug while charging, as this may cause damage to the vehicle or charging equipment, or even electric shock.
- It may affect medical or implantable electronic devices when charging. Consult the manufacturer of the electronic device before charging.
- Do not touch the metal terminals inside the charger or charging port, to avoid electric shock.
- Do not touch a malfunctioning charging station. If there is an abnormality, press the emergency stop switch immediately and contact a professional as soon as possible.
- Before charging, ensure that there is no water or foreign objects in the charging port and charging connector port, and that the metal terminals are not damaged or affected by rust or

corrosion. If any, do not charge. Abnormal terminal connection may cause short circuits or electric shock, resulting in hazarding to personal life.

- After charging, do not disconnect the charger with wet hand or when you stand in the water, for it may cause the electric shock and the personal injury.
- If you find any abnormalities with the vehicle or charging equipment during charging, please stop charging immediately.
- It is recommended not to charge the vehicle during thunderstorms, as lightning strikes may cause damage to the vehicle and charging equipment, and cause personal injury.
- Ensure that the charging equipment is disconnected from the charging port before driving the vehicle.

Caution

- Non-standard charging equipment may not be able to charge the vehicle.
- If the vehicle is locked while charging, the charger cannot be removed. It needs to unlock the vehicle or stop charging before the charger can be removed.
- Charging with the A/C system turned on will extend the charging time.
- In winter or in cold weather areas, charging time will be extended.
- The cooling fan will automatically turn on to cool the battery during charging, which is a normal phenomenon.

Hint

- When charging, use standard charging pile equipment, and charge correctly according to the charging pile instructions.
- The charging environment should be dry and ventilated, and there are no flammable and explosive items around.
- It is recommended to charge the vehicle at least once every two weeks until it is fully charged.
- When the vehicle battery drops below 20%, it needs to be charged for maintenance. If the low battery warning light in the car is on, it indicates that the power battery's charge is about to run out. Please charge the battery in time; otherwise, it may affect the service life of the power battery.
- When the ambient temperature is low, the charging time will be extended, which is a normal phenomenon.
- To ensure the best performance of the battery, the system automatically adjusts the charging current according to temperature changes.

7 Driving

7.8.3 Charging (Configuration 2)

I. Charging port (Configuration 2)

The vehicle is equipped with two types of charging ports and can be charged at different charging stations.

1. DC charging port (fast charging).
2. AC charging port (slow charging).

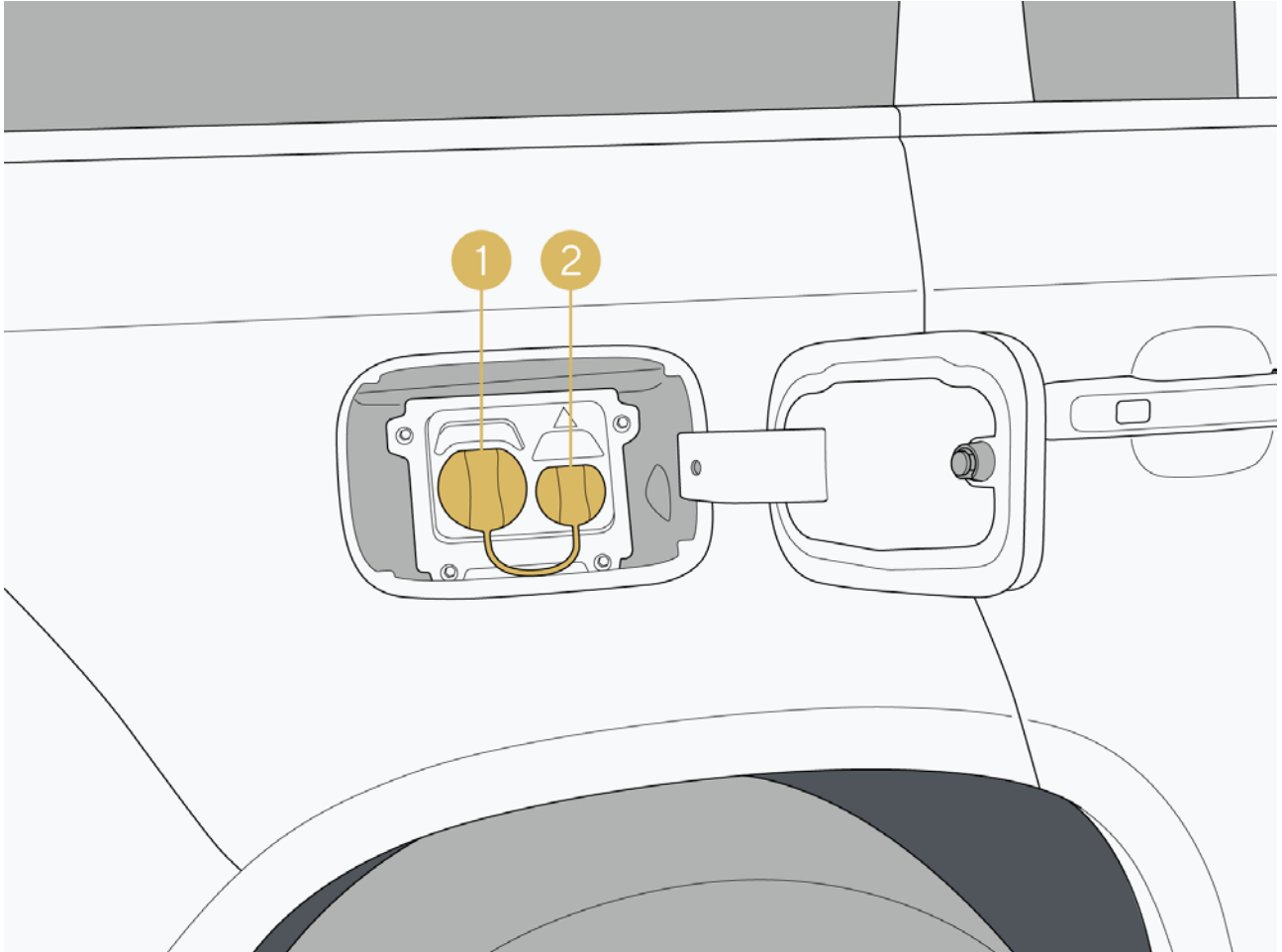

II. Charging indicator light

The charging indicator light is located at the charging interface.

Indicator color at the charging port	Status	Color meaning
White	Normal lighting	Ready, but charger/discharger not inserted
Blue	Flash	Connecting with charging/discharging equipment communication
	Normal lighting	Charger/discharger inserted or waiting for reservation charging
Green	Flash	Charging or discharging

Indicator color at the charging port	Status	Color meaning
	Normal lighting	Charging completed or discharging completed
Orange	Normal lighting	Charger/discharger is not fully inserted
Red	Normal lighting	Charge/discharge failure, charging stopped

III. Opening and closing the charging port cover

- Opening: When the vehicle is in P gear and unlocked, press the back of the charging port cover to open it.

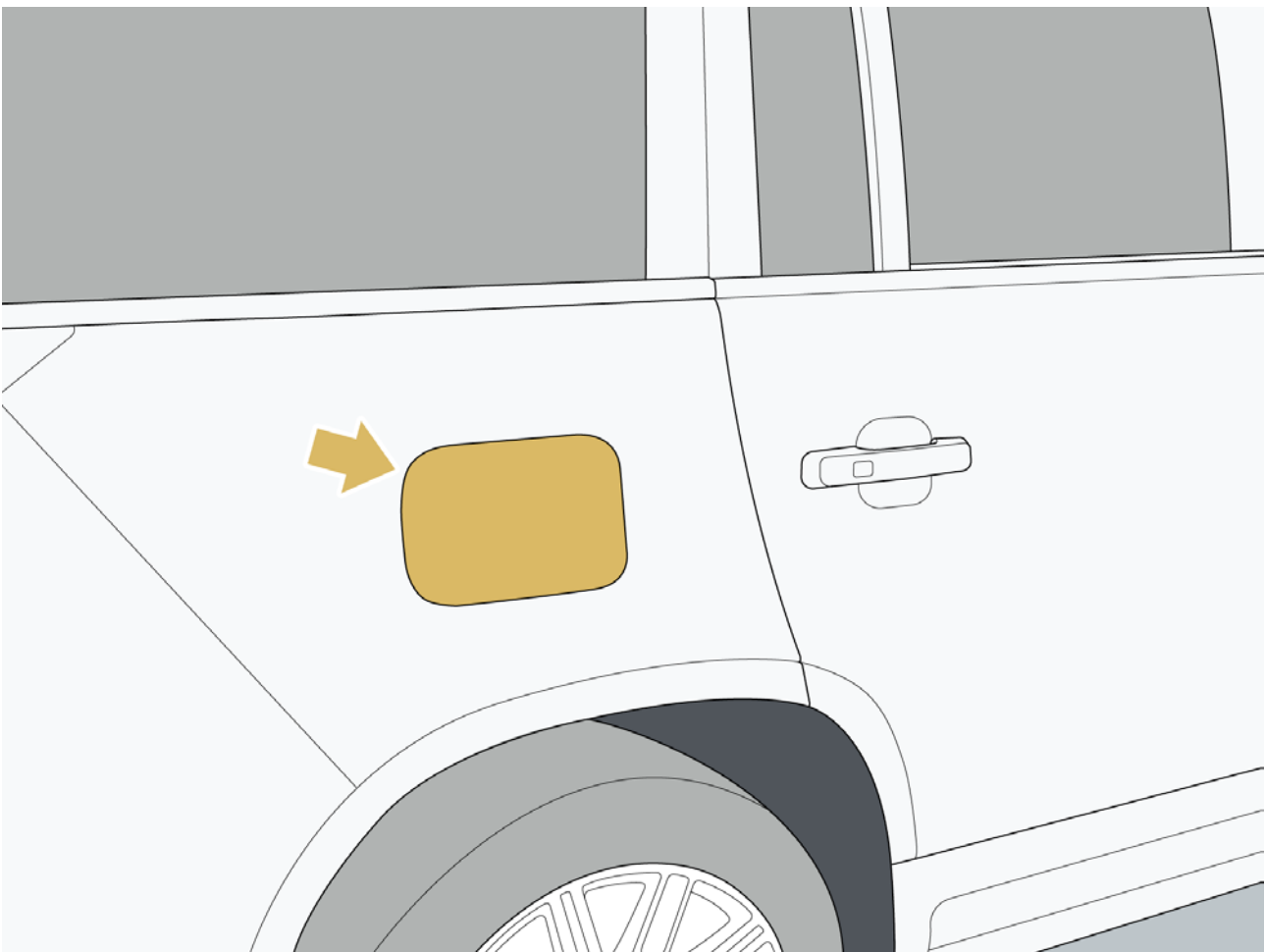

7 Driving

- Closing: After charging, cover the charging port dust cover, gently push the charging port cover until you hear a “click,” and the charging port cover is closed securely.

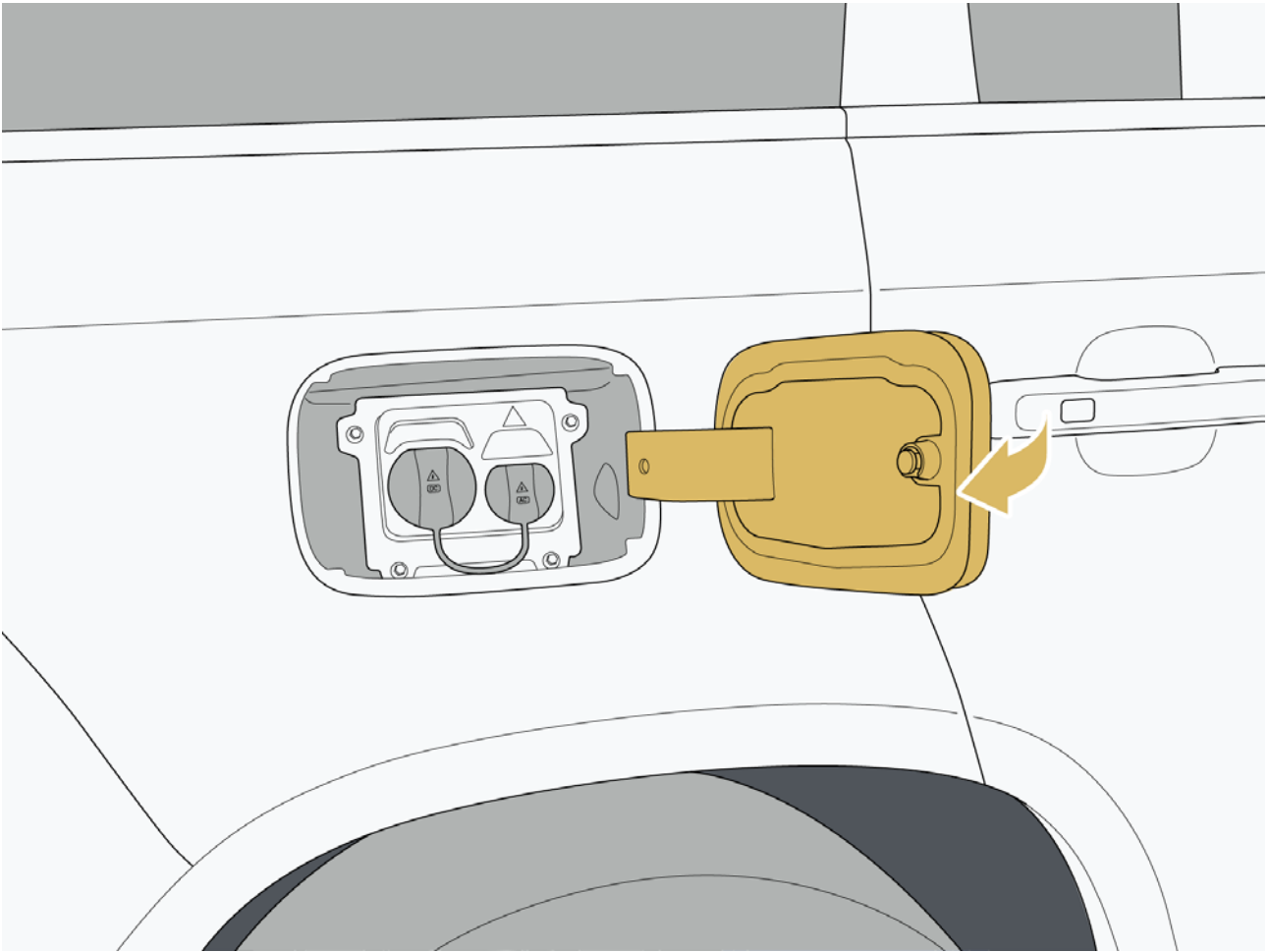

IV. Charging operation process

1. Make sure to switch the vehicle to P gear before charging.
2. Open the charging port cover, remove the dust cover of fast/slow charging port as needed.
 - If using fast charging, please remove the fast charging dust cover 1.
 - If using slow charging, please remove the slow charging dust cover 2.

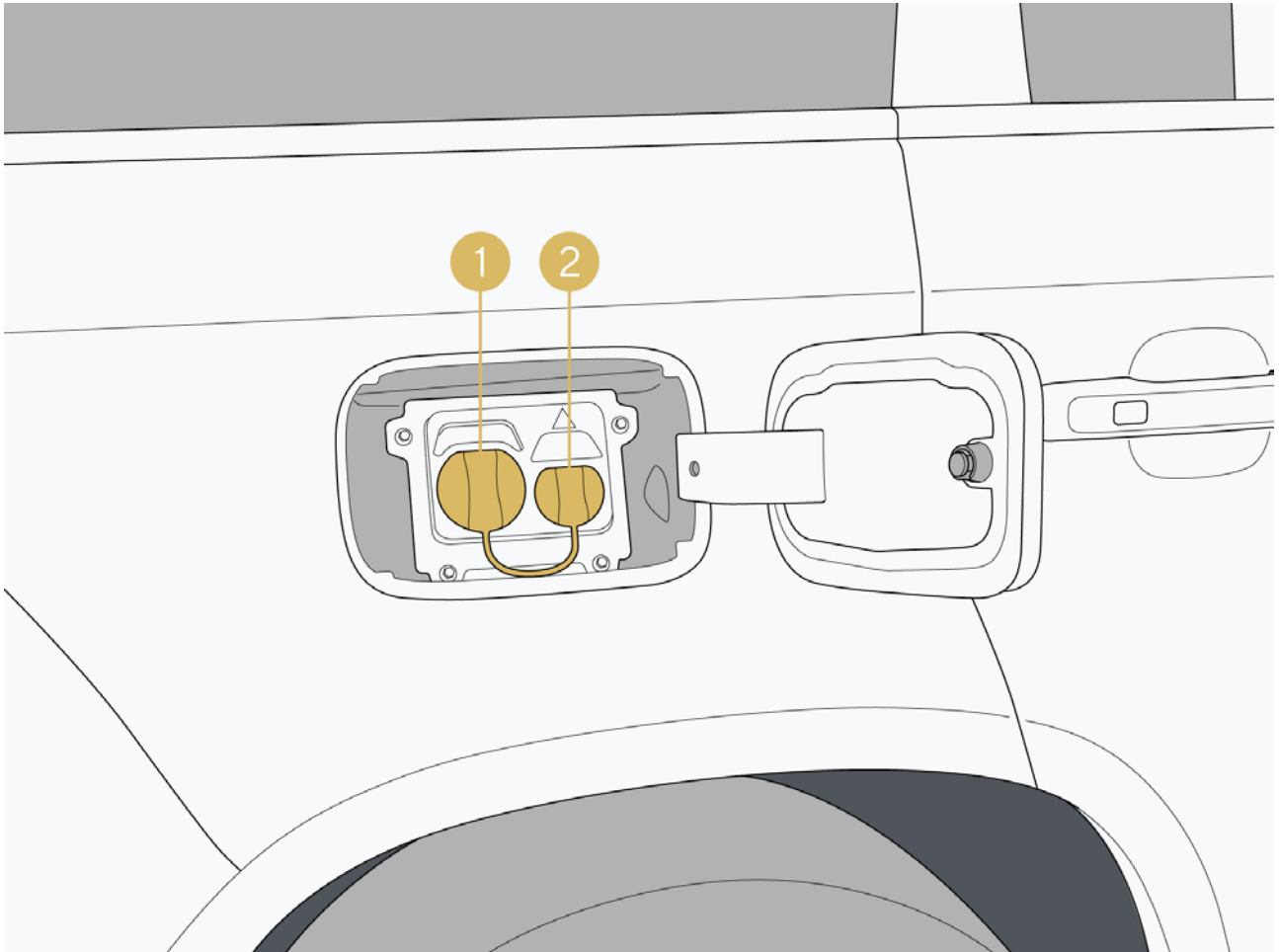

7 Driving

- 3. Before inserting the charger, please familiarize yourself with the charging equipment operation guide and check if the charging equipment is intact, then connect the charger to the charging port. After the charger is connected, you can view the charging status through the central control screen.
- Common charging prompts on the central control screen:

Successful connection.

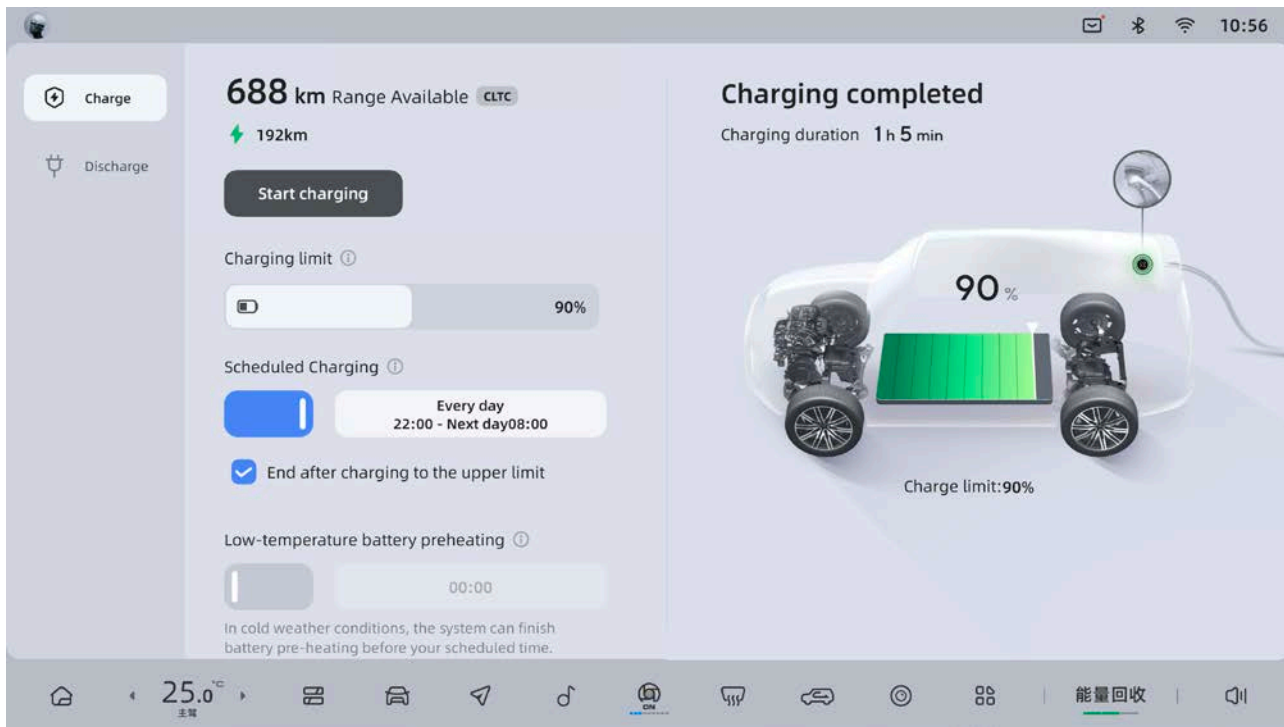

Charging

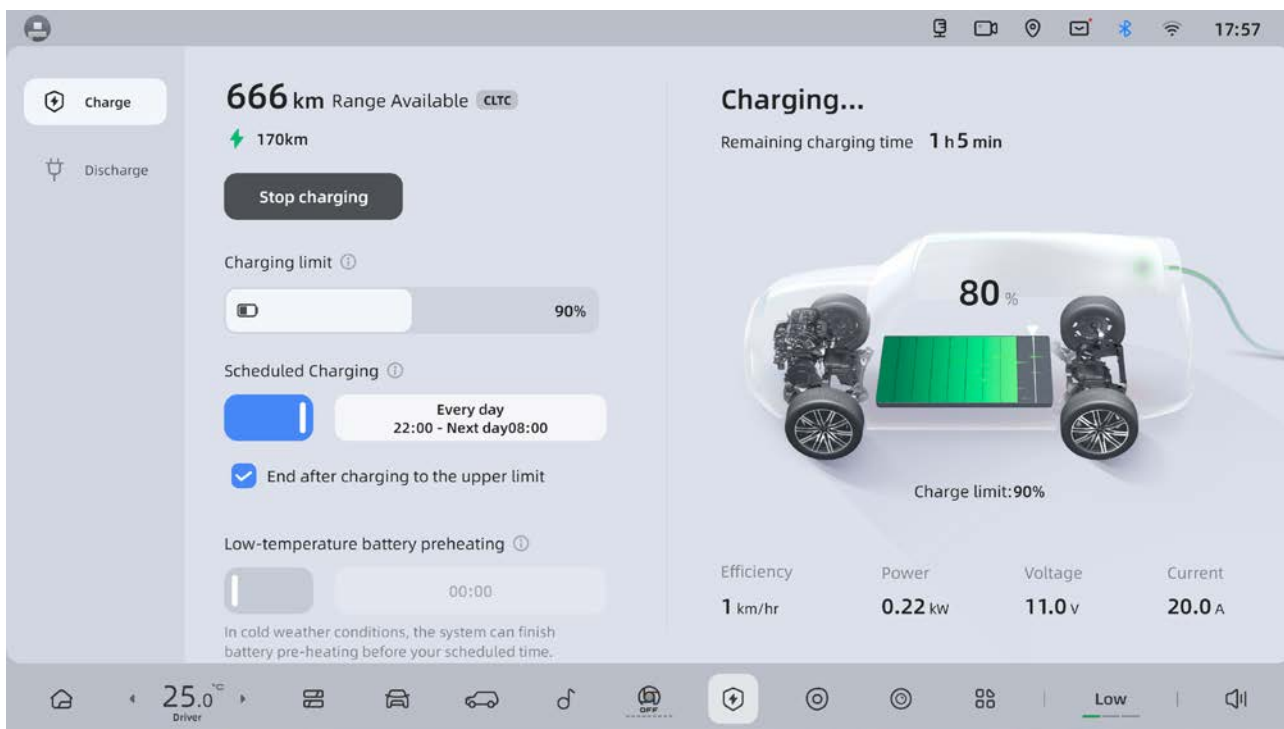

End of charge

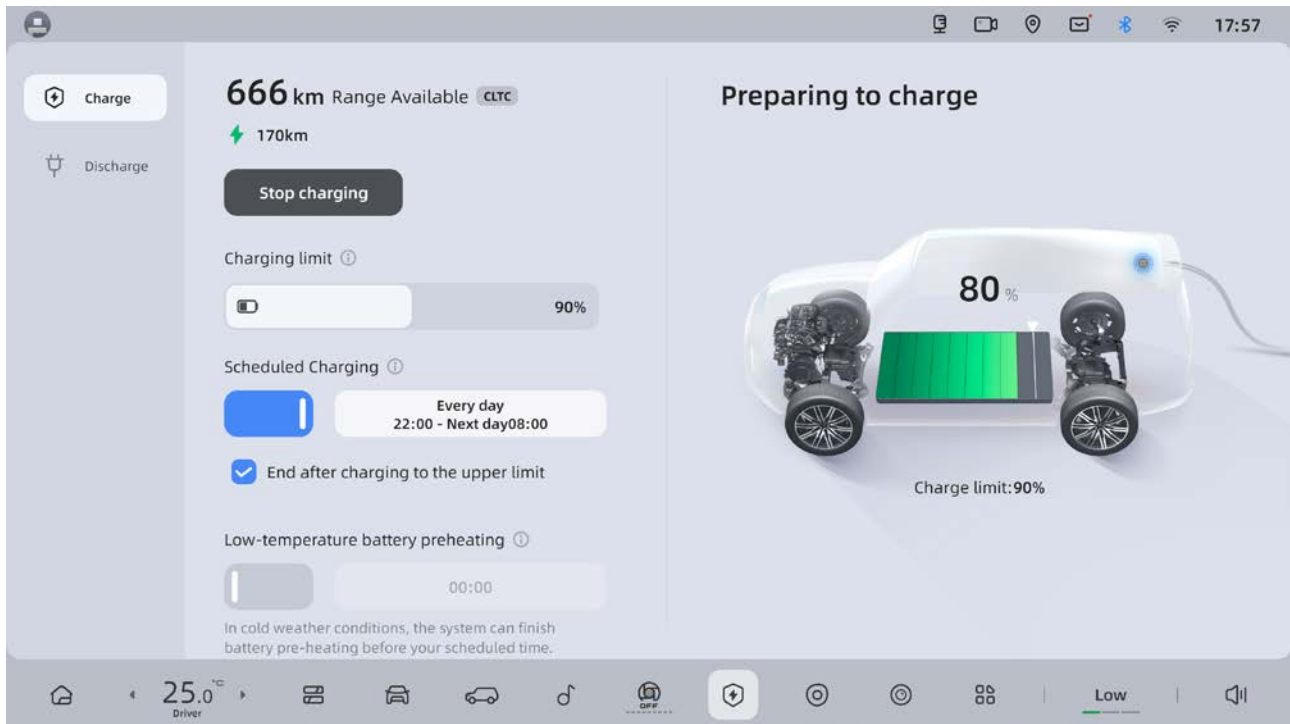

V. Low temperature battery preheating

When using a car in cold weather, reserving battery heating in advance will effectively increase battery life.

In the charging management interface, click "Low-temperature Battery Preheating" and set the battery preheating completion time.

VI. Parking power generation

When the vehicle power is low, use the parking power generation function. The range extender is started to charge the battery.

Click "Parking Power Generation" through the charging control interface to turn on or off the parking power generation function. When using the parking power generation function, the following requirements must be met:

- The vehicle is in P gear.
- The battery level is less than 80%.
- The charger is not inserted.
- The hood is closed.
- Non exhibition mode.
- The range extender is not disabled (such as when the trailer mode is enabled)

When using the parking power generation function, it can be turned off manually. Or it can be turned off automatically in any of the following situations:

- The charger is connected.

7 Driving

- The vehicle is not in P gear.
- The battery level has reached 80%.
- The vehicle is locked.
- It enters exhibition mode.

Caution

- When using parking power generation, please park the vehicle in a safe area to avoid safety accidents.

VII. Removing and unplugging the charger

- After slow charging is complete, the vehicle will automatically unlock the charger, and it can be unplugged directly.
- If it is necessary to stop charging during the slow charging process, click “Stop Charging” in the charging management interface or unlock the charger by pressing the unlocking button on the remote key.
- During or after the fast charging process, the charger can only be removed after the fast charging station stops charging.

VIII. Charging setting

1. Reservation charging: In the charging management interface, click “Reservation Charging” to enable or disable reservation charging. When reservation charging is enabled, click the option under the “Reserved Time” to set the start time for reservation charging.
2. Charging limit: In the charging management interface, slide the slider under “Charging Limit” to set the charging limit for the power battery (setting range: 80% ~ 100%).
3. Stop charging: In the charging management interface, click the “Stop Charging” icon to stop charging.
4. Start charging: In the charging management interface, click the “Start Charging” icon to start charging.

IX. Charging information

Slow charging: If using a 7 kW AC charging station, the battery can be fully charged in about 8 h and 30 min. If using a 11 kW AC charging station, the battery can be fully charged in about 6 h.

Fast charging: If using a 100 kW DC charging station, the battery can be charged from 30% to 80% in about 30 min.

X. Charger(slow charging) locking/unlocking

The locking/unlocking strategy of the electronic lock must meet the requirements of relevant standards. When the charger is inserted into the charging port, the charging port locks the charger with an electronic locking device (electronic lock) to ensure charging safety.

1. Automatic locking/unlocking

During charging, the electronic lock automatically locks. After charging is complete, the electronic lock automatically unlocks.

If you need to remove the charger during charging or while waiting for scheduled charging, please first unlock the vehicle and remove the charger within 30 s. Otherwise, the electronic lock on the charging port will be re-locked.

2. Emergency unlock

If the electronic lock fails and cannot unlock the slow charging port, it can be unlocked through the emergency unlock handle below the right side of the trunk.

1. Open the trunk door and remove the luggage compartment mat.
2. After removing the luggage compartment mat, take out the toolbox from the trunk and pull the emergency unlock handle to unlock the electronic lock of the charging port.

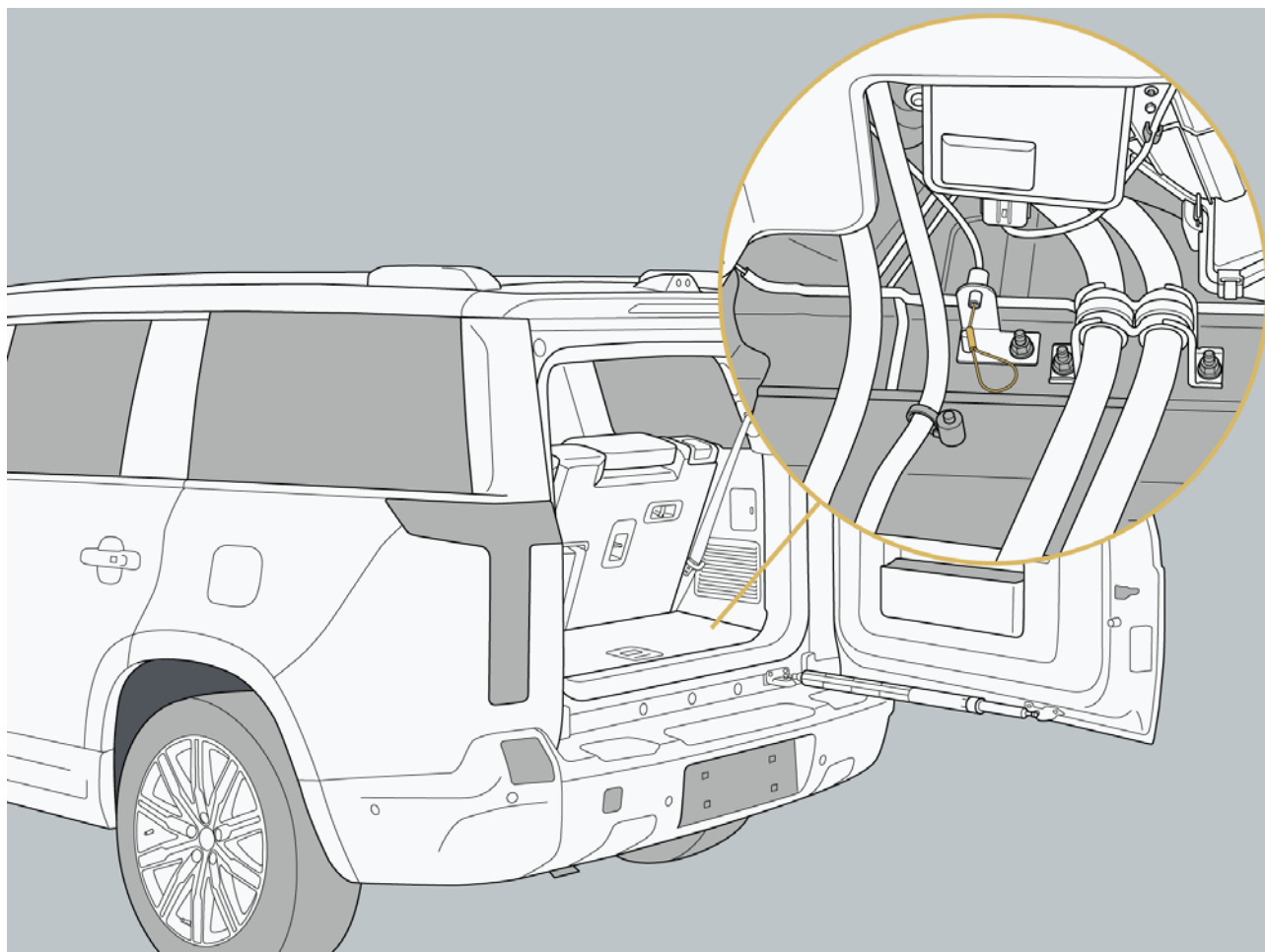

7 Driving

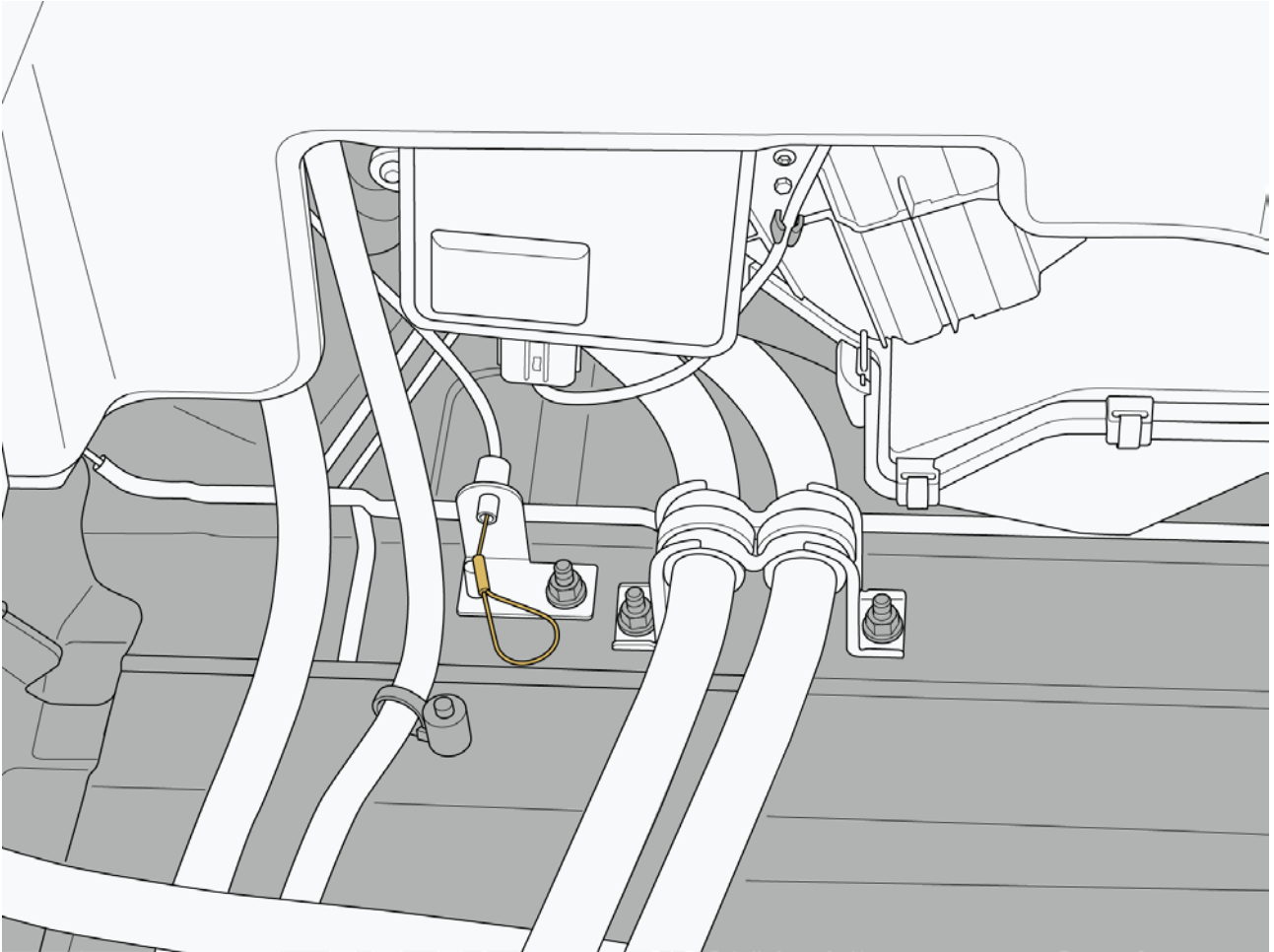

Warning

- If the pure electric range displayed on the instrument panel drops to 0, it must be charged within 24 h. If it is not charged within 7 days, it may cause permanent damage to the battery. If the vehicle cannot be charged, please contact the ROX Service Center immediately.
- Do not charge when the charging equipment is damaged, rusted, damp, or has foreign objects, to avoid electric shock.
- Do not wash the charging port area while charging, to avoid damage to the vehicle or charging equipment.
- Do not forcefully pull out the plug while charging, as this may cause damage to the vehicle or charging equipment, or even electric shock.
- It may affect medical or implantable electronic devices when charging. Consult the manufacturer of the electronic device before charging.
- When charging, it is necessary to ensure that the other charging port without a charger is always protected by the dust cover to prevent dust or sand from entering and causing wear on the terminals, thereby affecting the service life of the vehicle and charging equipment.
- Do not touch the metal terminals inside the charger or charging port, to avoid electric shock.

- Do not touch a malfunctioning charging station. If there is an abnormality, press the emergency stop switch immediately and contact a professional as soon as possible.
- Before charging, ensure that there is no water or foreign objects in the charging port and charging connector port, and that the metal terminals are not damaged or affected by rust or corrosion. If any, do not charge. Abnormal terminal connection may cause short circuits or electric shock, resulting in hazarding to personal life.
- After charging, do not disconnect the charger with wet hand or when you stand in the water, for it may cause the electric shock and the personal injury.
- If you find any abnormalities with the vehicle or charging equipment during charging, please stop charging immediately.
- It is recommended not to charge the vehicle during thunderstorms, as lightning strikes may cause damage to the vehicle and charging equipment, and cause personal injury.
- Ensure that the charging equipment is disconnected from the charging port before driving the vehicle.

Caution

- Non-standard charging device may not be able to charge the vehicle.
- If the vehicle is locked while charging, the charger cannot be removed. It needs to unlock the vehicle or stop charging before the charger can be removed.
- Charging with the A/C system turned on will extend the charging time.
- In winter or in cold weather areas, charging time will be extended.
- The cooling fan will automatically turn on to cool the battery during charging, which is a normal phenomenon.
- During the charging process, if the charging port indicator light remains red and constantly on, it is recommended to replace the charging station and try again. If the indicator light still remains red and constantly on, please stop charging immediately and contact the ROX Service Center.

Hint

- When charging, use standard charging pile equipment, and charge correctly according to the charging pile instructions.
- The charging environment should be dry and ventilated, and there are no flammable and explosive items around.
- It is recommended to charge the vehicle at least once every two weeks until it is fully charged.
- When the vehicle battery drops below 20%, it needs to be charged for maintenance. If the low battery warning light in the car is on, it indicates that the power battery's charge is about to run out. Please charge the battery in time; otherwise, it may affect the service life of the power battery.

7 Driving

- When the ambient temperature is low, the charging time will be extended, which is a normal phenomenon.
- To ensure the best performance of the battery, the system automatically adjusts the charging current according to temperature changes.

7.8.4 External discharge (Configuration 1)

The external discharge function can output the electricity stored in the power battery at 220 V, supplying external appliances with a maximum power of 3500 W.

I. Discharging port

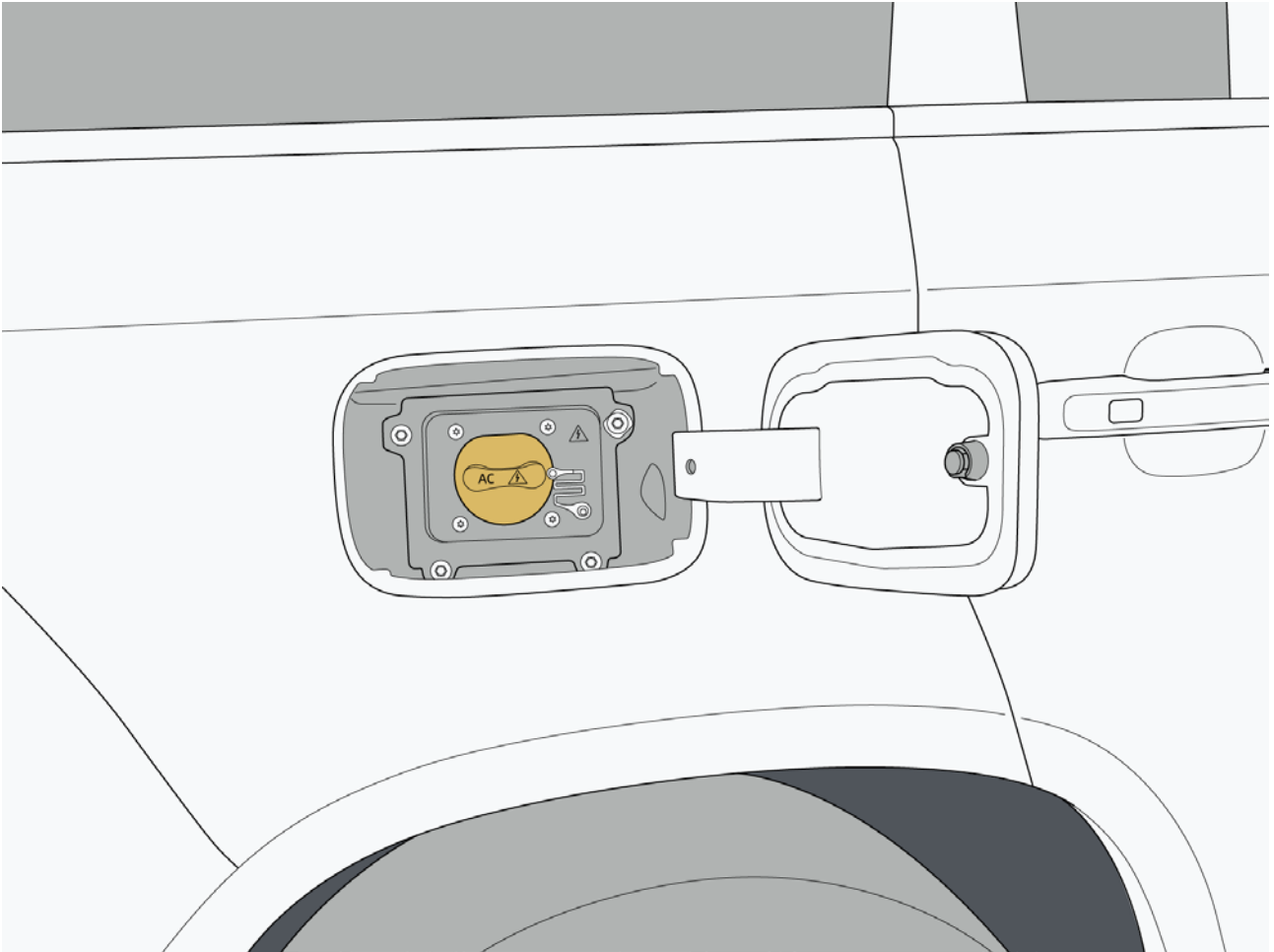

7 Driving

II. Start or stop discharging

1. Start discharging

After inserting the converter, enter the discharge management interface. In the discharge management interface, you can set the lower discharge limit, check the connection status of the converter, vehicle cruising range and other information.

If the converter is not inserted, the discharge management interface will prompt "Please insert the converter."

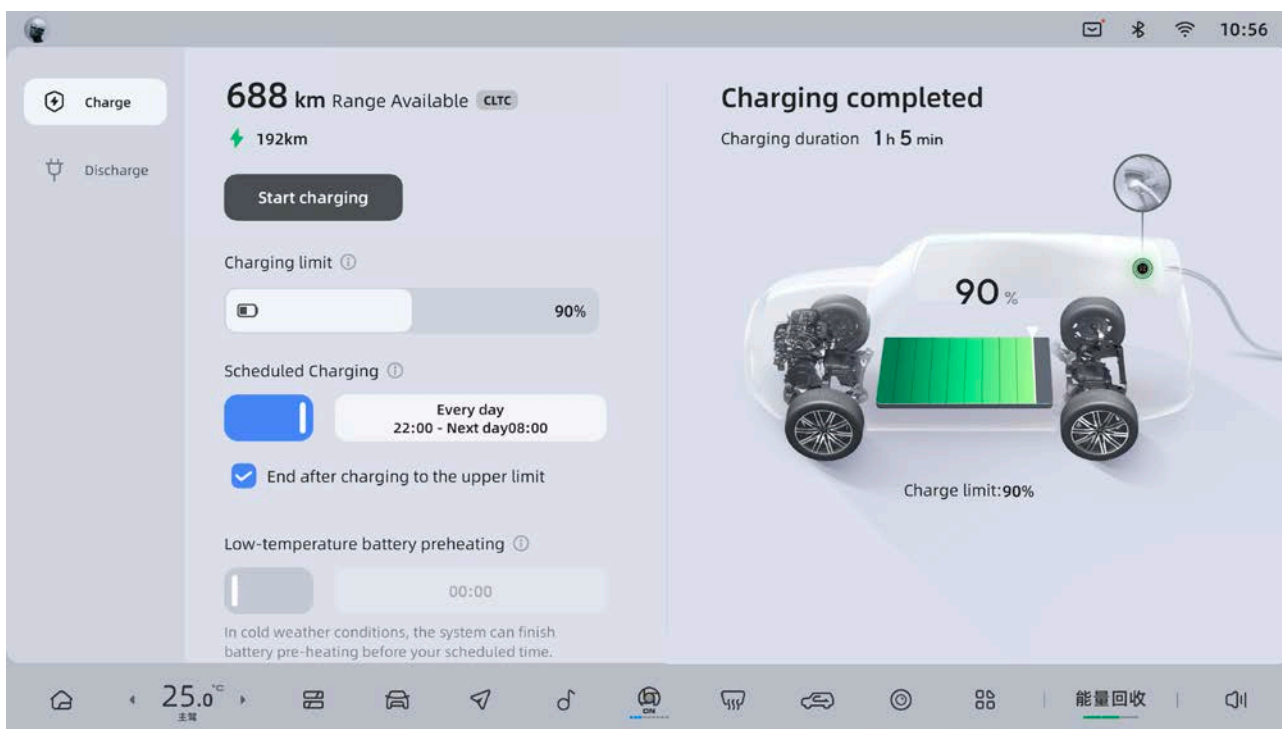
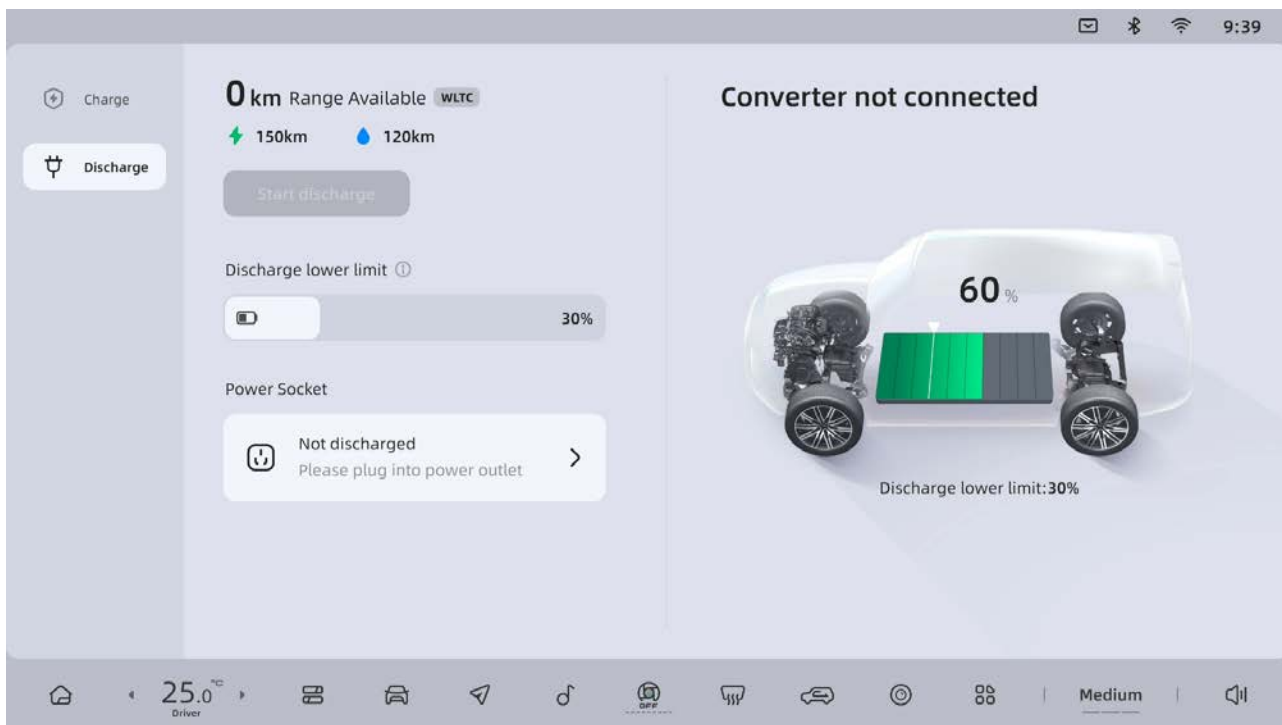

After inserting the converter, the “Start Discharging” icon will be highlighted. Click the “Start Discharging” icon to start external power supply.

Lower limit of discharge: The power battery will discharge to the set lower limit, after which the range extender will start, keeping the power battery level at the set lower limit. The vehicle will stop discharging when the fuel level reaches a low level.

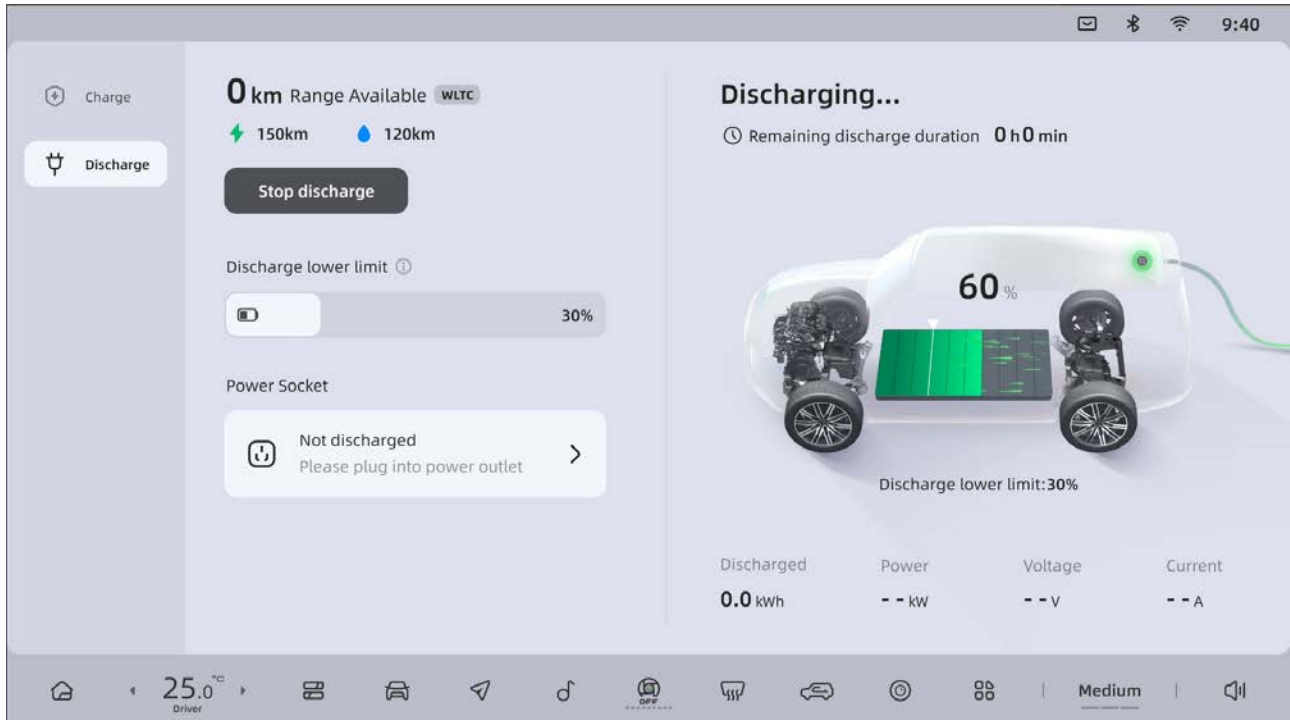

7 Driving

2. Stop discharging

During external discharging, click the “Stop Discharging” icon to end external discharging.

Hint

- The converter and 220 V socket can work simultaneously, and the maximum converter power should not exceed 3,500 W. Otherwise, overload protection will stop the output. The maximum power of the 220 V socket should not exceed 2,200 W. Otherwise, overload protection will stop the output.

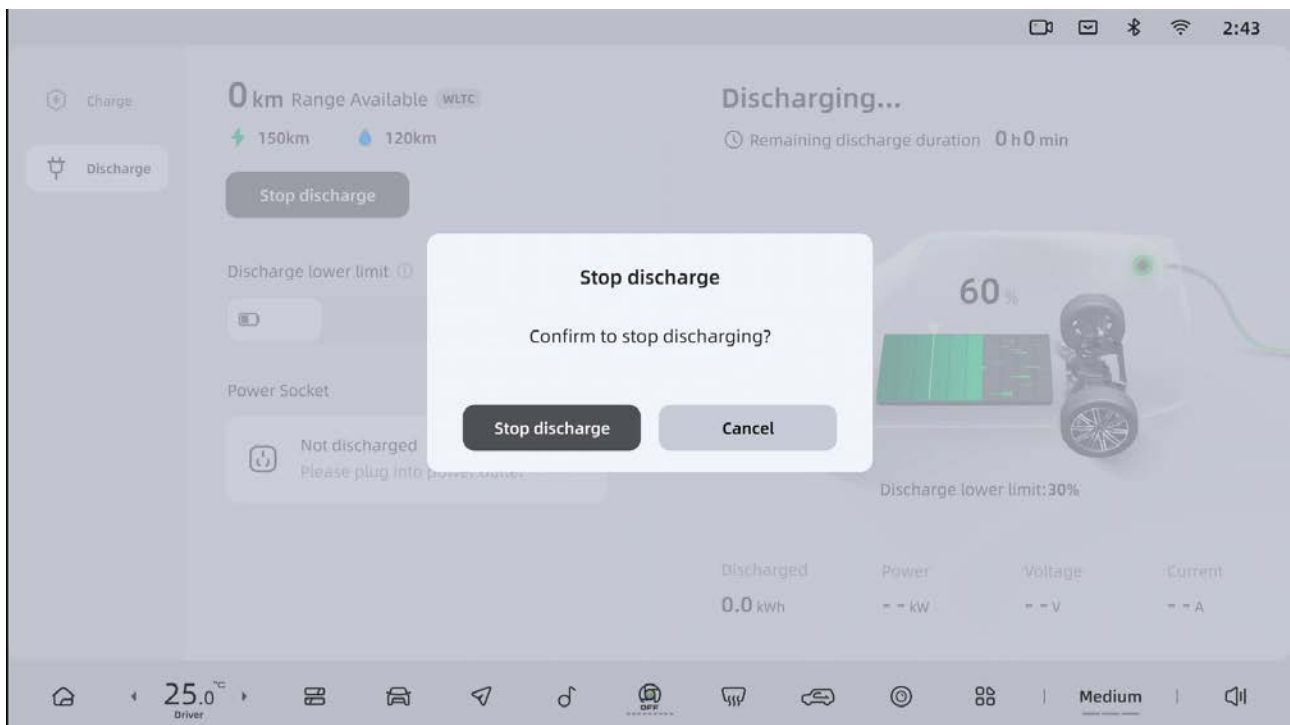

III. Install the converter

1. Open the charging port cover
2. Remove the charging port dust cover.
3. Check if the converter is damaged, and then insert the converter into the charging port. After the connection is successful, the discharge management interface will prompt "Connection Successful".
4. When the converter is successfully connected or the discharge is stopped, and there is no abnormality in the discharge system, click the "Start Discharge" button on the control screen to start the external discharge.

IV. Remove the converter

1. In the discharge management interface, click “Stop Discharging” or the power supply has ended.
2. Unplug the converter, install the charging port dust cover, and close the charging port cover.

Warning

- Do not discharge when the converter is damaged, rusted, damp, or has foreign objects, to avoid electric shock.
- Do not forcefully pull out the converter while discharging, as this may cause damage to the equipment or vehicle, or even electric shock.
- If there are any abnormalities during discharging, please stop the discharging.
- Do not discharge when the discharger head or the charging port is deformed, blackened or ablated.
- Do not discharge when there are obvious water stains in the charging port, to avoid damage to the vehicle or discharge equipment, or even electric shock.
- Do not touch the plug pins and adapter sockets of the load device.

7 Driving

7.8.5 External discharge (Configuration 2)

The external discharge function can output the electricity stored in the power battery at 220 V, supplying external appliances with a maximum power of 2,200 W. (If using the national standard GBT 16A converter, the maximum discharge power is 3500W.)

I. Discharging port

The function of supplying 220V AC power to other electrical appliances can be achieved through the AC charging port and the V2L converter.

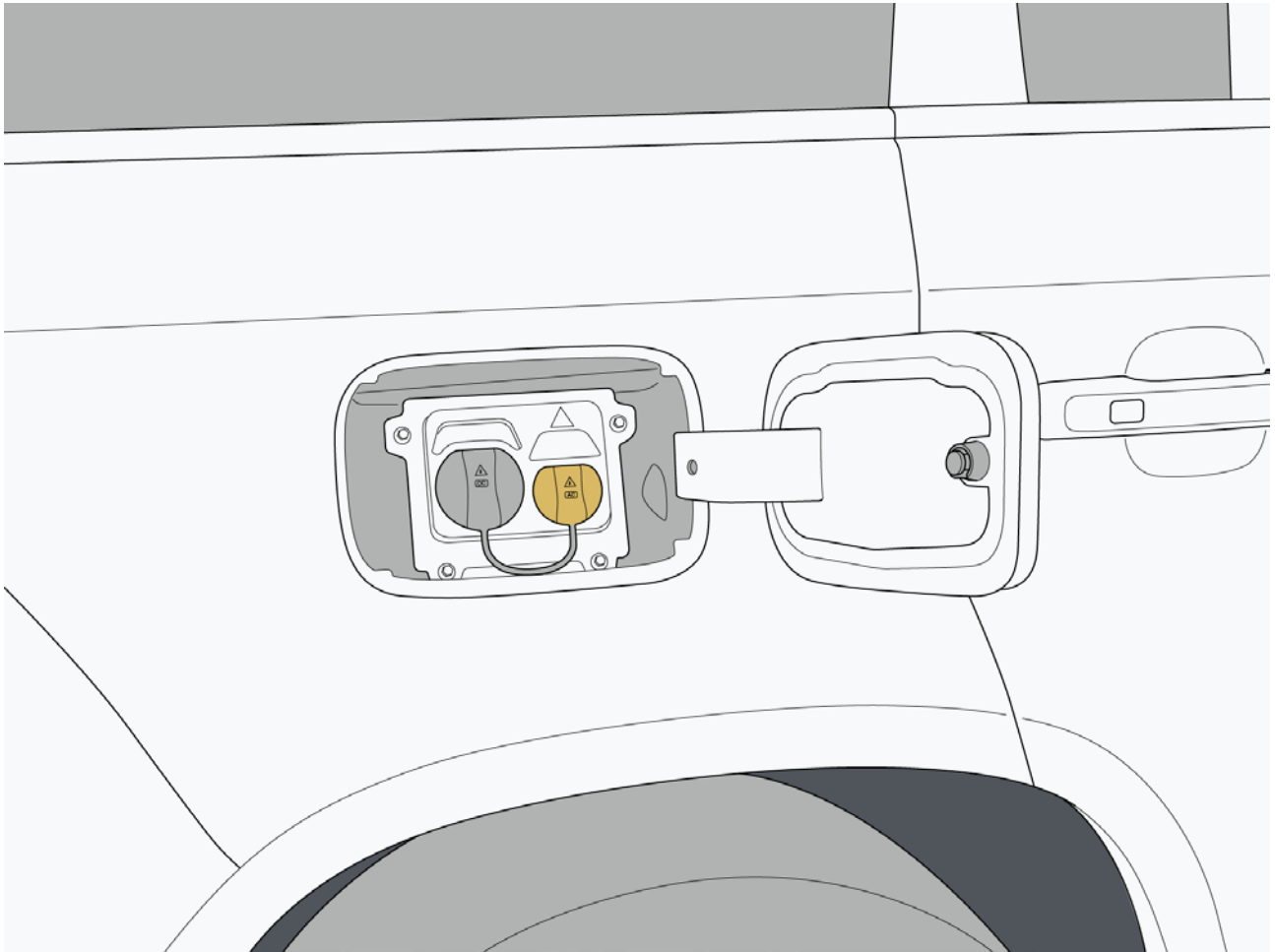

II. Start or stop discharging

1. Start discharging

After inserting the converter, enter the discharge management interface. In the discharge management interface, you can set the lower discharge limit, check the connection status of the converter, vehicle cruising range and other information.

If the converter is not inserted, the discharge management interface will prompt “Please insert the converter.”

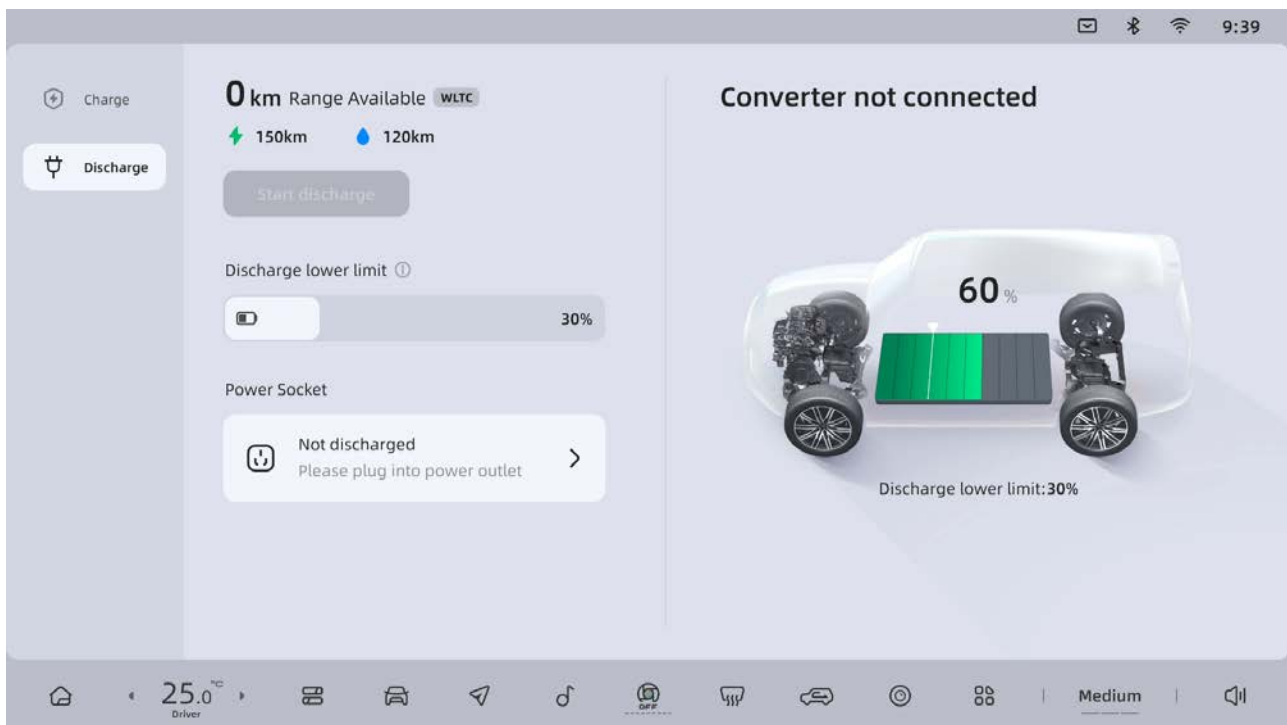

After inserting the converter, the “Start Supplying” icon will be highlighted. Click the “Start Supplying” icon to start external power supply.

Lower limit of discharge: The power battery will discharge to the set lower limit, after which the range extender will start, keeping the power battery level at the set lower limit. The vehicle will stop discharging when the fuel level reaches a low level.

7 Driving

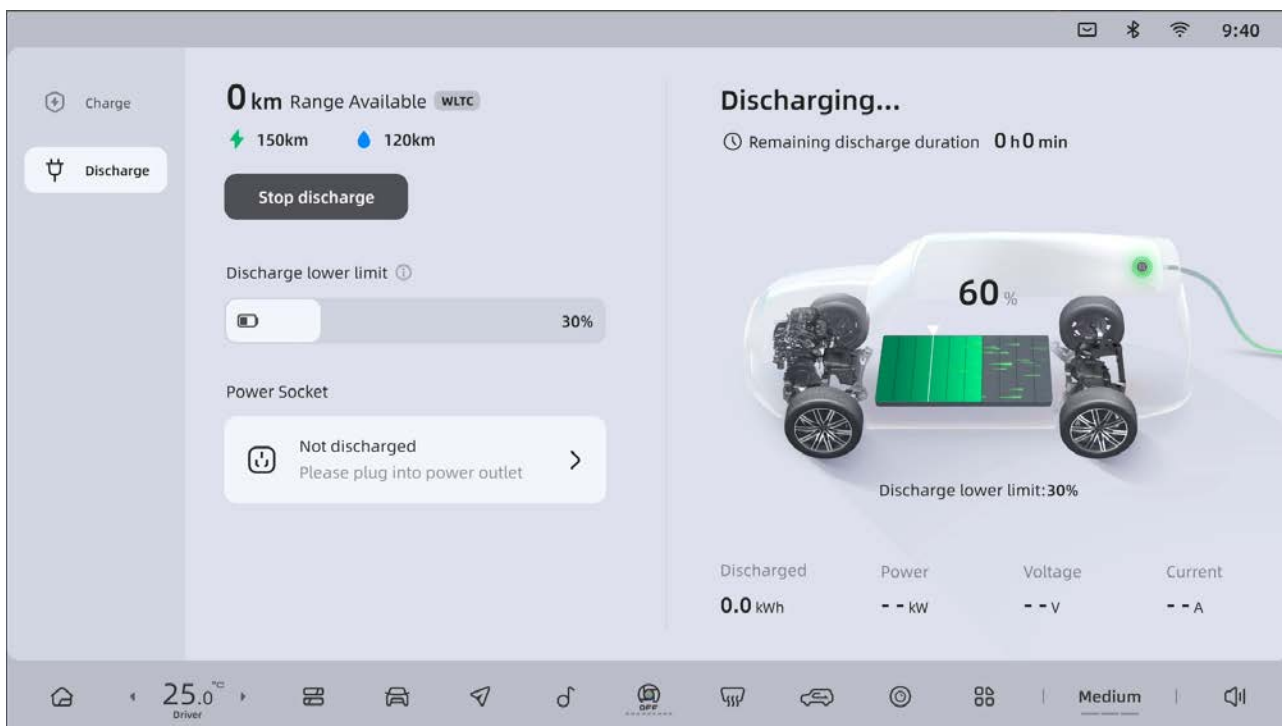

2. Stop discharging

During external discharging, click the “Stop Discharging” icon to end external discharging.

Hint

- The converter and 220 V socket can work simultaneously, but the maximum output power of each circuit should not exceed 2,200 W. Otherwise, overload protection will stop the output.

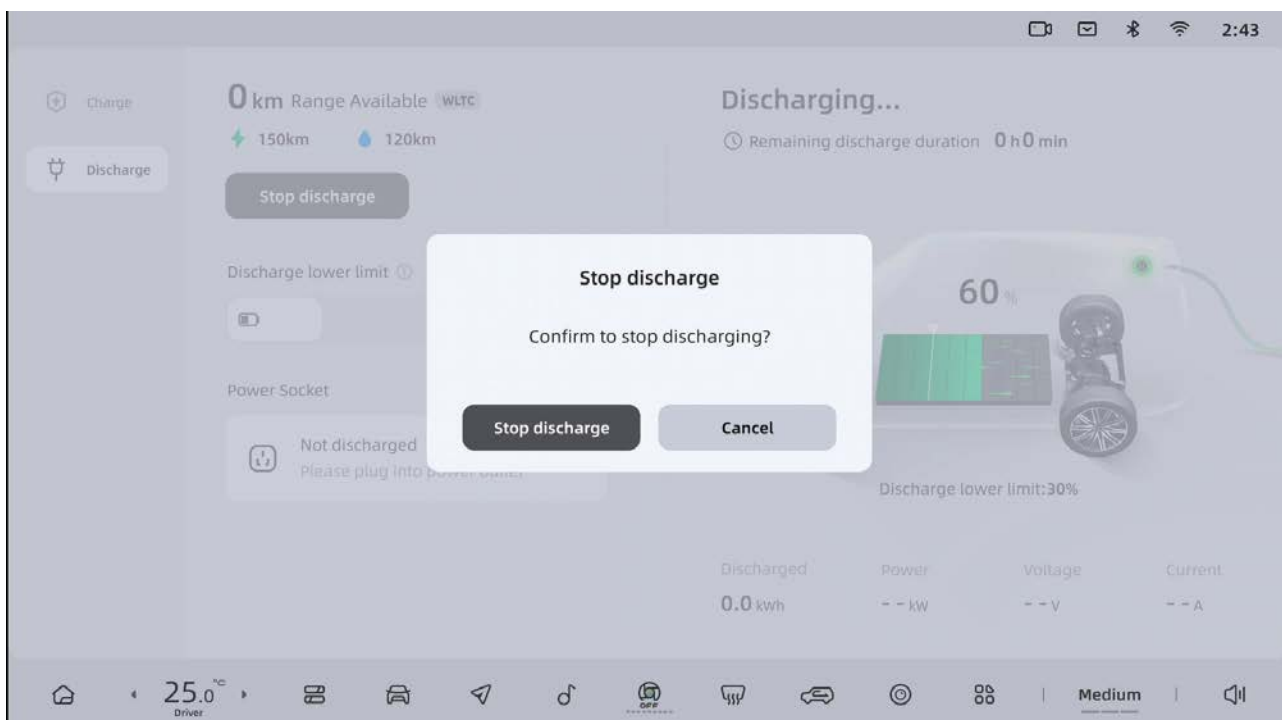

III. Install the converter

1. Open the charging port cover
2. Remove the slow charging port dust cover.

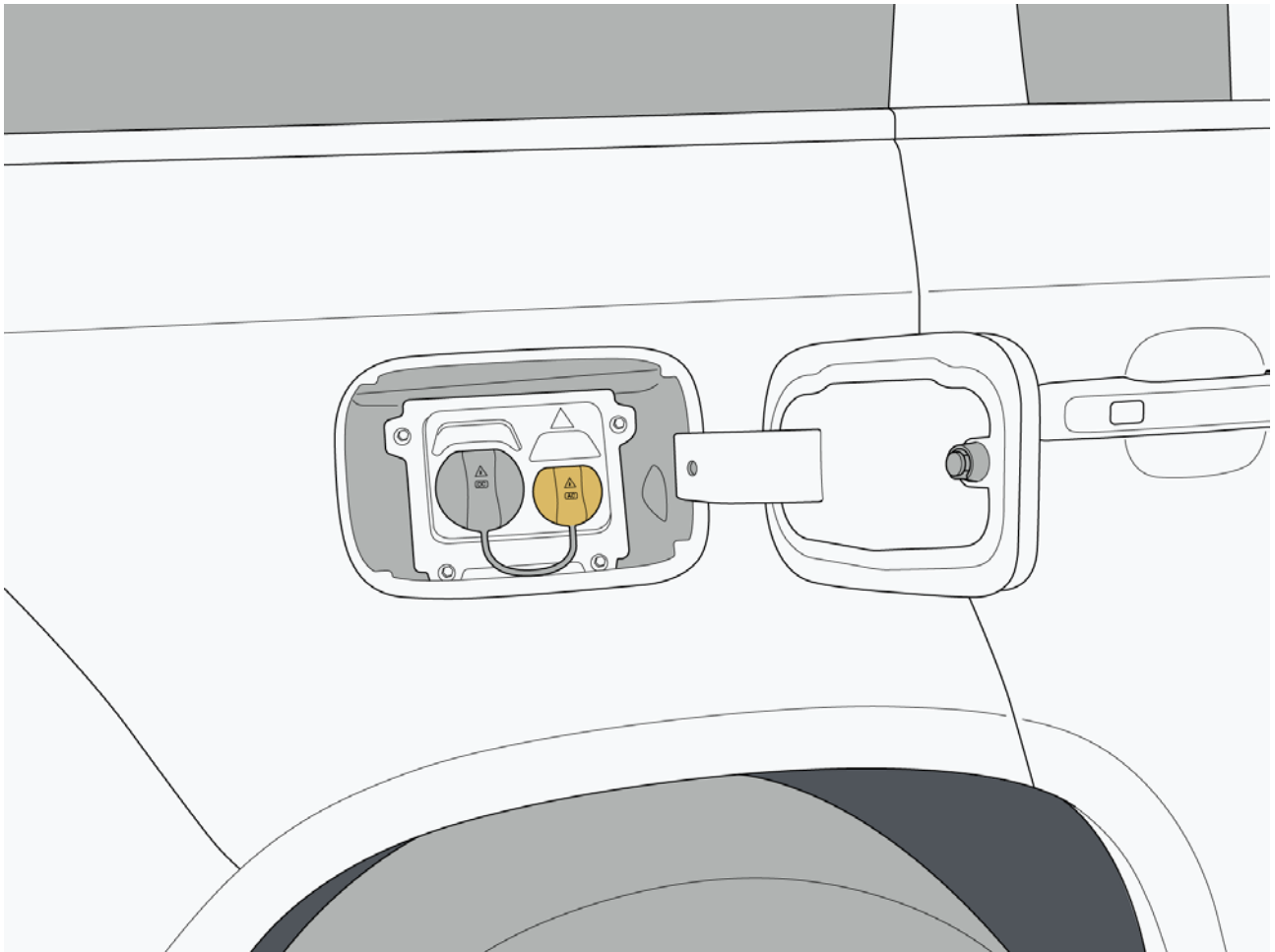

7 Driving

3. Check if the converter is damaged, and then insert the converter into the slow charging port. After the connection is successful, the discharge management interface will prompt "Connection Successful".
4. When the converter is successfully connected or the discharge is stopped, and there is no abnormality in the discharge system, click the "Start Discharge" button on the control screen to start the external discharge.

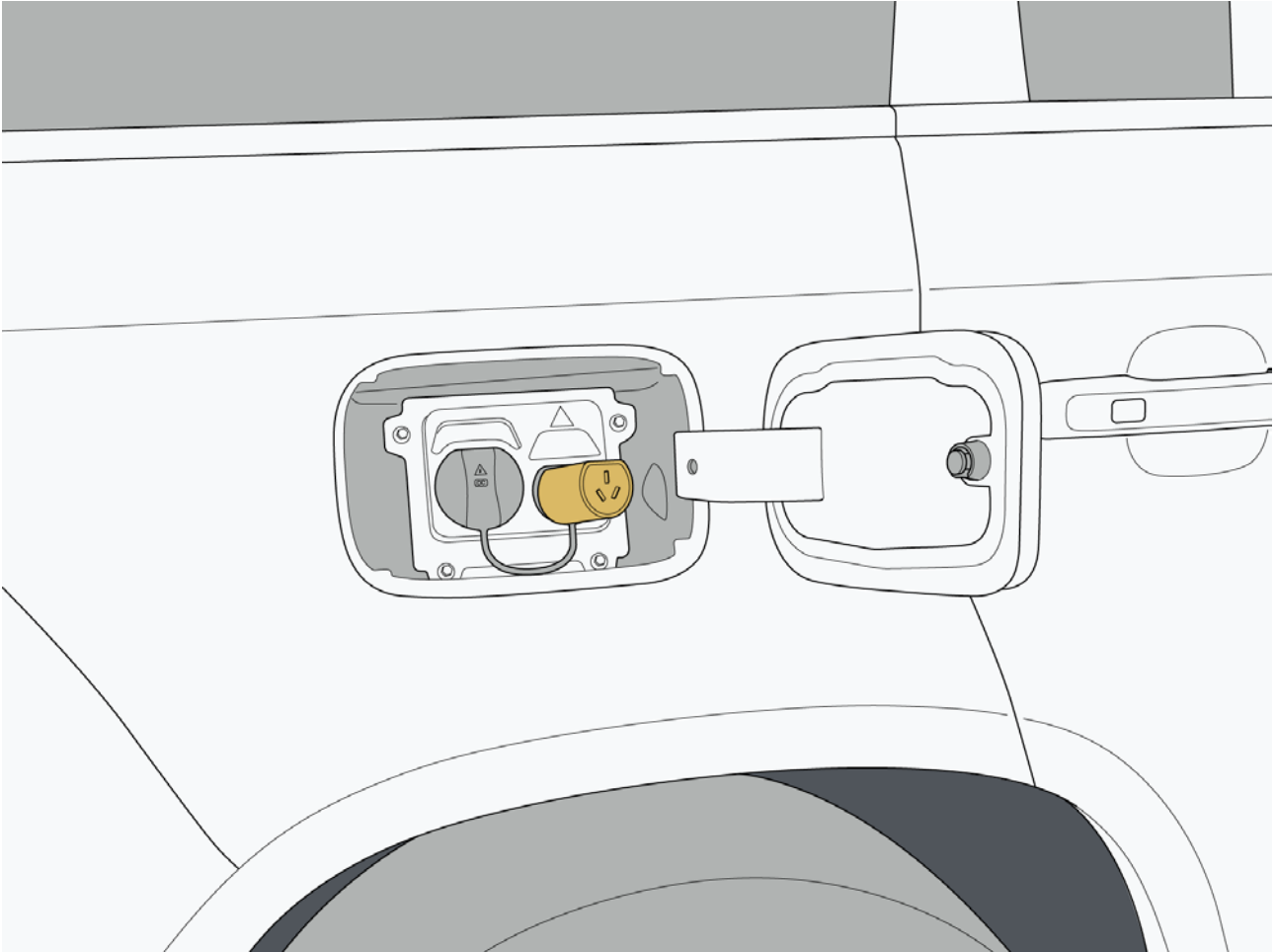

IV. Remove the converter

1. In the supply management interface, click “Stop Supplying” , or the power supply has ended.
2. Unplug the converter, install the charging port dust cover, and close the charging port cover.

Warning

- Do not discharge when the converter is damaged, rusted, damp, or has foreign objects, to avoid electric shock.
- Do not forcefully pull out the converter while discharging, as this may cause damage to the equipment or vehicle, or even electric shock.
- If there are any abnormalities during discharging, please stop the discharging.
- Do not discharge when the discharger head or the charging port is deformed, blackened or ablated.
- Do not discharge when there are obvious water stains in the charging port, to avoid damage to the vehicle or discharge equipment, or even electric shock.
- Do not touch the plug pins and adapter sockets of the load device.

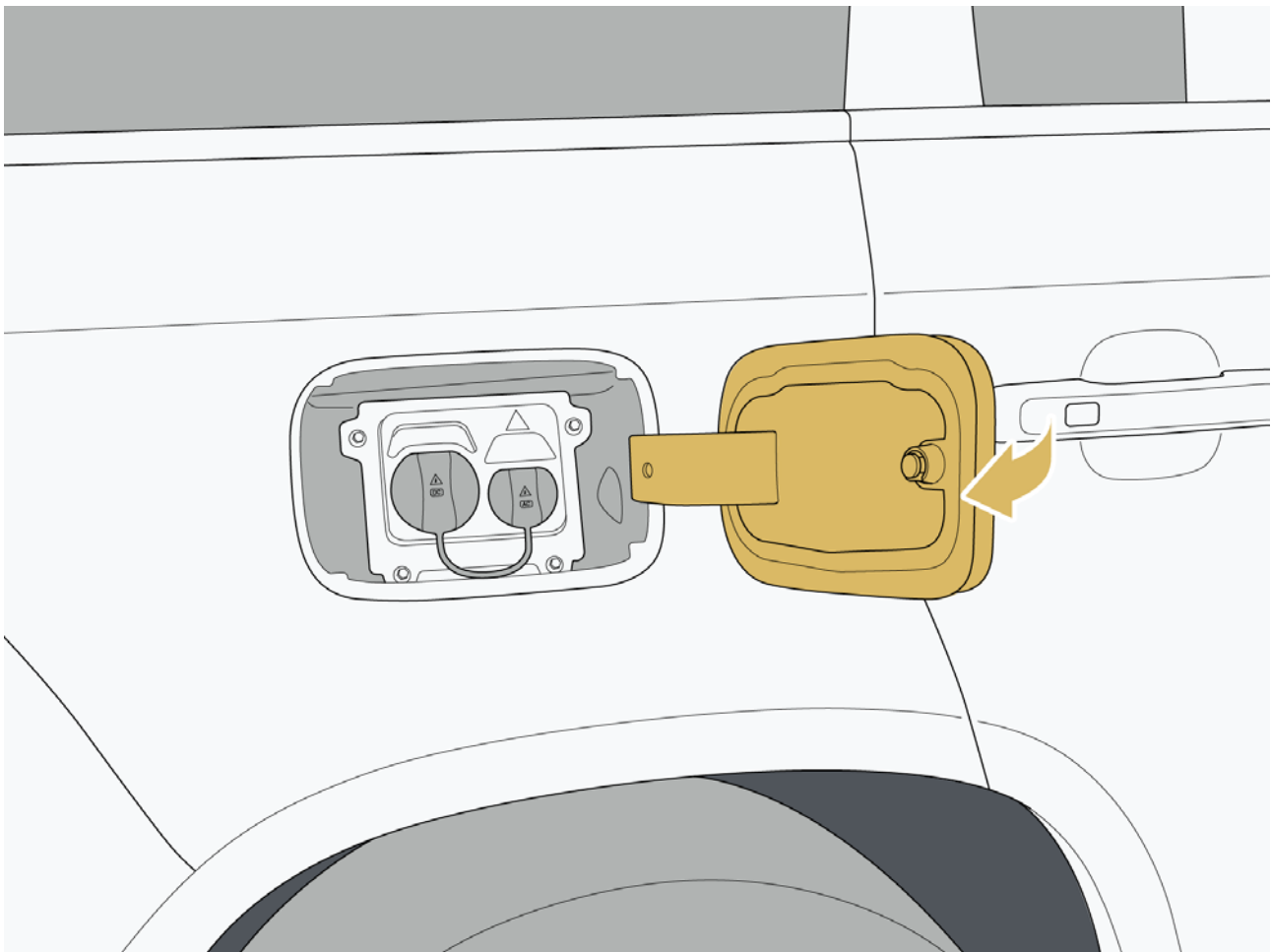

7 Driving

7.8.6 Power battery

I. Power battery

The power battery is the power source of the vehicle and can be charged and discharged repeatedly. The power battery is charged by an external power source, and the vehicle also can be charged through the motor during braking, coasting, or when the range extender is activated.

The power battery is located under the vehicle's floor, so be careful to prevent it from being knocked or bumped when driving over rough roads or uneven surfaces. The power battery is only suitable for this vehicle and must not be used on other vehicles or modified in any way. This will avoid electrical shocks, overheating, smoking, explosions, or leakage of electrolyte, etc.

II. Range

The range of the vehicle depends on the available electric energy, vehicle age (current battery life), weather conditions, temperature, road conditions, driving habits, etc.

- The range is related to the depth of discharge. To avoid excessive discharge that may affect the performance of the power battery, it is recommended to charge the vehicle in a timely manner after the low battery warning light on the central control screen is displayed.
- The use of A/C will reduce the range.
- In low-temperature conditions, the range will decrease during use due to the temperature characteristics of the battery, and the charging time will increase. Maintain a remaining range of no less than 80 km when using the vehicle.
- There will be some variation in the range at different speeds.

The following methods can be used to increase the range:

- Regularly maintain the vehicle.
- Keep tire pressure appropriate.
- Minimize the use of the vehicle in extreme weather conditions.
- Remove unnecessary items from the vehicle to reduce the load.
- At high speeds, close the windows to reduce air resistance, and conserve energy.
- Maintain a steady speed and try to avoid aggressive driving.

III. Power battery recycling

Information about the power battery will be recorded when the vehicle is registered and licensed. When it needs to replace or scrap the power battery, please contact the ROX Service Center for proper recycling and disposal. Scrapping of or discarding the power battery arbitrarily will pollute the environment or cause safety incidents. The owner will be responsible for the consequences.

Warning

- Improper dismantling, dismantling and storage of power batteries will cause personal injury and pollute the environment.

- Do not touch high-voltage system components to avoid electric shock.
- The complete vehicle's high-voltage harness is orange. Do not damage or pull on the high-voltage harness and plugs to avoid electric shock.
- Do not disassemble, disassemble or replace the power battery without authorization.
- Do not hand over discarded or old power batteries to unqualified recycling service outlets or individuals, or you will be responsible for the consequences.

Eco-friendly

- The power battery contains toxic substances and corrosive substances. Arbitrary scrapping or discarding of the power battery will pollute the environment.

8 Maintenance and repair

8.1 Maintenance and repair

8.1.1 New car run-in

I. Brake gear

After the vehicle runs about 500 km, the brake disc and brake pad can achieve better braking performance. Therefore, during this running-in period, please drive with caution.

II. Tire

The adhesion performance of new tires is not at its best. For the first 300 km, which is the running-in period, drive at appropriate speeds and with caution, which can extend the tire's lifespan and enhance safety.

III. After replacing parts

During the driving time after the running-in period, if the tires, braking devices, etc. are replaced with new parts, they must be run-in again according to the relevant regulations.

8.1.2 Vehicle cleaning

I. Vehicle cleaning

To protect the vehicle and maintain it in the best condition, perform the following manual cleaning operations:

1. Rinse the vehicle from top to bottom with a large amount of clean water to remove dust.
2. Wash the body of the vehicle with a sponge or soft cloth.
3. For hard-to-remove substances, first soften them with detergent and then rinse with clean water.
4. After washing, carefully dry the vehicle's paint surface with a soft towel.
5. Do not directly rinse the front bumper grille with a water gun. It is recommended to keep a distance of more than 300mm and use a fan-shaped cleaning method to avoid damaging the condenser.

II. Automatic car wash

1. Before washing, fold the exterior rearview mirrors and close the windows completely.
2. It is best to use fabric washing device when washing the vehicle to avoid damaging the paint.
3. Wash the vehicle from top to bottom from the front.
4. After washing, carefully dry the vehicle's paint surface with a soft towel.
5. Before driving, make sure the exterior rearview mirrors are unfolded.
6. After washing the vehicle, gently depress the brake pedal several times in succession to remove any residual water from the brake discs. This can avoid affecting braking effectiveness and prevent rusting of the brake discs.

III. Cleaning the wheel hub

1. When removing stubborn stains, do not use hard brushes or abrasive cleaners.
2. Do not use detergent on hot wheel hubs.
3. After the wheel hubs cool down, you can use special wheel hub detergent. Rinse them off immediately after applying.

IV. Car lights

1. When cleaning car lights, do not dry wipe or use abrasive or corrosive detergents.
2. For stubborn dirt, first soften it with detergent and then wash it away with water.
3. Remove ice with deicing spray. Do not use a deicing shovel.

Warning

- Keep the charging port cover and tank cap closed during vehicle cleaning to avoid damage.
- Do not wax the surface of the car lights. Avoid damaging the car lights.
- High-pressure car washing with excessive water pressure may damage the paint.
- Do not rinse the vehicle's dust cover with a high-pressure water gun for a long time.
- Do not wash the high-voltage components at the bottom of the vehicle to avoid electrical shock or vehicle damage.

8.1.3 Vehicle maintenance

I. Vehicle paint

Regular daily maintenance helps ensure driving safety and vehicle value retention. Environmental factors such as air pollution or natural impurities (resin or pollen, etc.) in certain areas may affect vehicle paint. Adjust the frequency and scope of vehicle maintenance accordingly.

Remove corrosive substances such as spilled fuel, engine oil, lubricant, or bird droppings immediately to prevent paint discoloration or fading.

II. Leather curing

Regularly remove dust and impurities from the leather surface with a towel or vacuum cleaner.

When the leather is contaminated, clean it in time. First wipe the dirt with a paper towel or towel, and then clean it with a little water on the towel. For stubborn stains, clean them with leather detergent. Finally dry the water stains on the surface.

Apply neutral care agent to the leather once a month for professional maintenance to maintain its quality.

8 Maintenance and repair

Caution

- Do not place sharp objects such as keys or scissors on the seats to avoid scratching or tearing the leather.
- Do not use alcohol, corrosive, acidic, or alkaline care agents, as they will damage the leather's protective layer.
- Do not turn on the seat heater to dry the seats. Do not treat the seat with an iron on the seats.
- Avoid soaking the seats with liquid.

III. Seat belt

Dirty seat belts may hinder retraction and affect safety performance. Seat belts should only be cleaned with mild soapy water. They can only be retracted when completely dry.

Caution

- Do not use bleach, dyes or cleaning solvents, as these can reduce the durability of the seat belts.
- Always wait for the seat belt to completely dry before retracting it. Avoid damaging the seat belt retractor.

IV. Wheel

To maintain the appearance of the wheel hub and prevent corrosion, it is recommended to thoroughly clean it with a neutral detergent every two weeks, focusing on removing brake dust and salt residue. After cleaning, protective coating can be sprayed to extend the maintenance effect.

V. Underbody protection

The vehicle's underbody is treated to withstand chemical and mechanical damage. However, damage to the protective layer is inevitable during driving. It is advisable to check the vehicle's underbody and chassis protection layer at regular intervals, preferably before winter and in spring, and make necessary repairs if required.

Hint

- If you often drive off-road under harsh conditions such as bumpy, muddy and sandy terrain, it is strongly recommended that you install a metal chassis guard.

VI. Cleaning and maintenance after special working conditions

After completing the deep off-road driving, thoroughly clean the air conditioning intake and the front grille, check the cooling effect of the air conditioning and the condition of the condenser, carefully inspect whether there is coolant leakage in the engine compartment and chassis, and clear the air conditioning drainage outlet (including the front and rear air conditioning drainage outlet, and do not

8 Maintenance and repair

pull the drainage pipes during the clearing process), shorten the replacement cycle of the air conditioning filter to half a year/10000 kilometers, and confirm that the insulation components of the engine compartment and chassis are securely fixed without loosening.

Chassis cleaning

After driving on dusty, sandy, rough or muddy roads, please wash your vehicle in time, and focus on washing the chassis area with clean water (pay special attention to the parts where dirt and impurities are easy to remain, as shown in the following table). If any damage or corrosion is found, please contact the ROX Service Center immediately.

Soil tends to accumulate in the chassis area
Brake caliper, friction plate, brake disc, mudguard
Suspension ball pin and bushing
Steering gear pull rod guard, ball pin
Steering gear intermediate shaft guard, cross shaft
Drive shaft sleeve
Front and rear air spring guards
Closed valve pump and shield

Special road condition maintenance

After driving under special conditions, please increase the frequency of vehicle maintenance.

If you often drive under the following conditions, it is recommended to contact the ROX Service Center at least every 3 months for professional testing and maintenance consultation.

Special road conditions include (but not limited to) the following:

Driving in desert/gravel/ice and snow/muddy/bumpy conditions;

Driving in mountainous conditions;

Driving through water;

Towing the trailer;

The maintenance items for special working conditions are as follows:

Maintenance item
Check the tire
Check the suspension ball pins and bushings
Check the steering gear motor, pull rod guard and ball pins
Check the steering intermediate shaft guard and cross shaft
Check the drive shaft sheath and lock nuts
Check the brake calipers, friction plates, brake discs, and mudguards
Check the wheel hub bearing

8 Maintenance and repair

Check the brake hoses and pipes
Check the front and rear shock absorbers
Check the front and rear air springs
Check the air spring tube
Check the air spring valve pump
Check the towing bar and towing hook

Note: The actual maintenance items may be adjusted due to different working conditions. Please refer to the final confirmation of ROX Service Center.

Off-road conditions

Off-road conditions require more stringent vehicle performance, so it is necessary to avoid extreme operations such as engine speeding for a long time and stalling to prevent the electric drive system from being damaged. If you plan to drive off-road, we recommend that you contact ROX Service Center before and after your trip. We will provide a comprehensive inspection for your vehicle to ensure it is always in the best condition and eliminate potential hazards in a timely manner.

VII. Precautions for air suspension

- In extremely cold weather, rubber components are more prone to damage. These minor damages may deteriorate rapidly at low temperatures, leading to serious problems such as air leakage. Car owner should regularly inspect the appearance of the air suspension system and check if there are any cracks, bulges or wear on the surface of the air springs. At the same time, check if there are any signs of aging, damage or loosening in the connecting pipelines. Once there is a problem with the pipelines, the suspension system will not be able to work properly.
- In extremely cold weather, try to park air suspension vehicles in indoor parking lots or underground garages as much as possible. These places have relatively high temperatures, which can effectively reduce the erosion of cold air on the air suspension system. If the vehicle can only be parked outdoors, it is recommended to park it on a flat ground and install a car cover, especially covering the chassis, to reduce the contact area between the air suspension components and the outside cold air and reduce the impact caused by extremely low temperature.
- If the vehicle needs to be parked for a long time in an extremely cold environment, empty the heavy objects in the vehicle when parking, so as to reduce the load of air spring. At the same time, start the vehicle regularly and let the air suspension system perform several complete lifting cycles to keep the flexibility of the components and prevent them from sticking or getting stuck due to the vehicle being stationary.
- After starting the vehicle in extremely cold weather, do not drive at high speed immediately, but let the vehicle idle for 5-10 minutes to warm up the engine and air suspension system gradually. During the preheating process, the air suspension system will perform self-check and adjustment. Please

8 Maintenance and repair

confirm whether the instrument screen has an air spring fault alarm. When starting, accelerate slowly to avoid excessive impact on the air suspension system caused by sudden acceleration.

8.1.4 Anti-corrosion

I. Common factors affecting vehicle corrosion

- Accumulated dirt, sand or ice under the body of the vehicle may accelerate corrosion.
- Industrial pollution, salt in the air in coastal areas and excessive road salt may accelerate the corrosion process of the paint.
- Increased temperature may accelerate the corrosion of poorly ventilated parts.
- Driving in high relative humidity or hot and humid environments may accelerate corrosion.
- Damage to the coating or other protective layers caused by sandstone impact or minor accidents may accelerate corrosion.

II. Anti-corrosion measures

- Wash the car regularly to keep it clean.
- Regularly check the paint for damage and repair it promptly.
- If you frequently drive on roads with snow-melting salt, salt-alkali soils or coastal areas with salt-containing roads, you should at least clean off any attachments from the bottom of the car every month.
- If the vehicle accumulates insects, asphalt, cement or other similar substances, clean them off promptly.

8 Maintenance and repair

8.2 Regular maintenance

8.2.1 Regular maintenance

Maintenance item	Maintenance cycle (subject to time or mileage, whichever comes first))	
	Time	Mileage
First maintenance for range extender system (oil, engine filter)	Six months	Range extender has worked for 5,000 km
Minor maintenance for range extender system (oil, engine filter)	1 year	Range extender has worked for 10,000 km
Major maintenance for range extender system (oil, filter, air filter element)	2 year	Range extender has worked for 20,000 km
A/C filter	1 year	20,000km
Spark plug	--	Range extender has worked for 40,000 km
Brake fluid	4 year	80,000km
Coolant	6 year	120,000km

8.3 Self-maintenance

8.3.1 Hood

I. Open the hood

Pull the engine hood unlock handle twice in succession to unlock the engine hood, and then lift the hood upward until it is fully open.

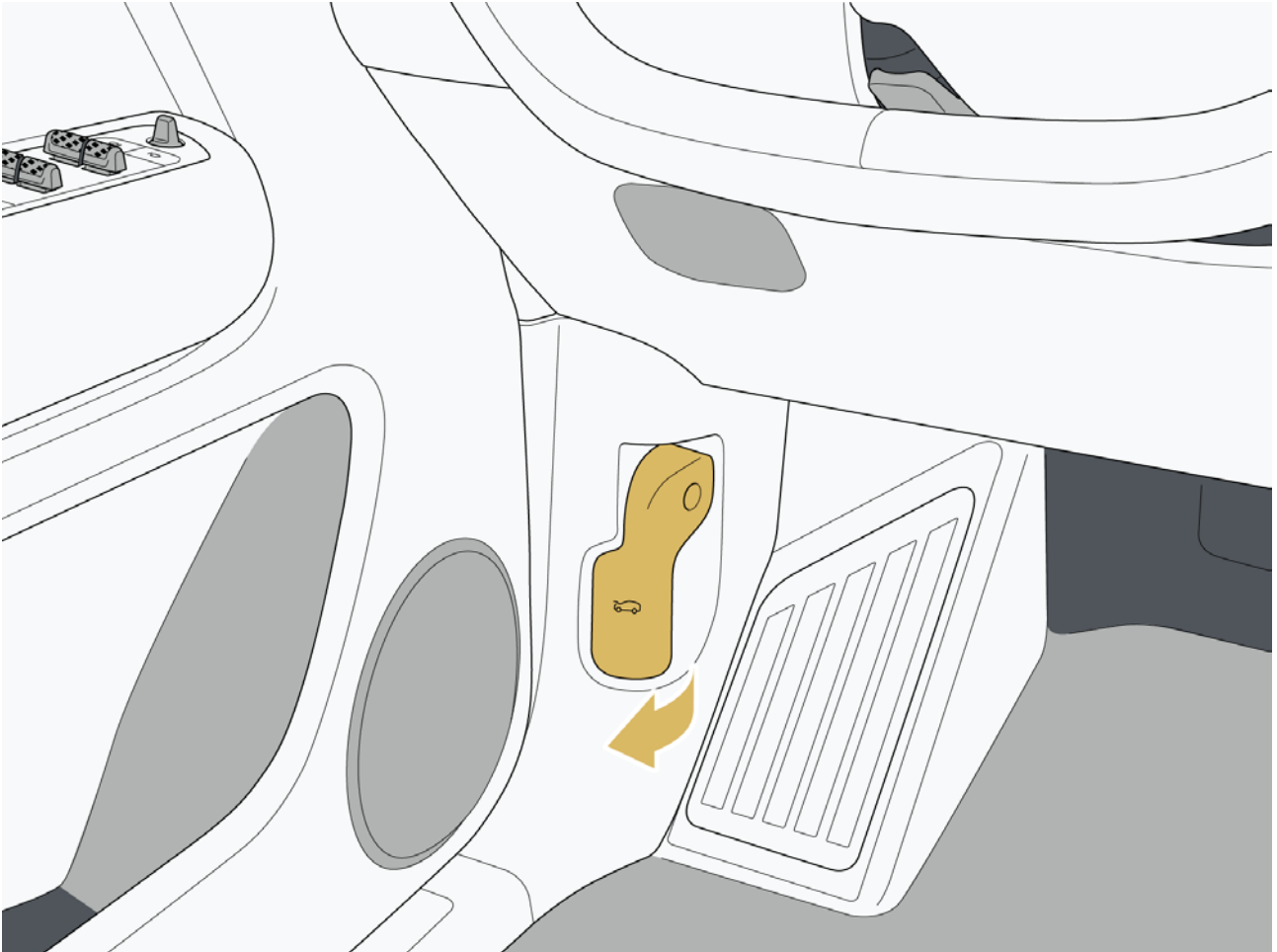

8 Maintenance and repair

II. Close the hood

Lower the engine hood to allow it to close under its own weight. If the hood is not fully locked, press down firmly on the front end of the hood. After closing the engine hood, try to lift it slightly to ensure that it is fully locked.

Warning

- Before opening or closing the hood, please check and ensure that there are no obstacles in the opening and closing path of the hood; otherwise, the vehicle may be damaged.
- Do not drive the vehicle with the hood half-unlocked, otherwise it may open during driving and cause an accident.

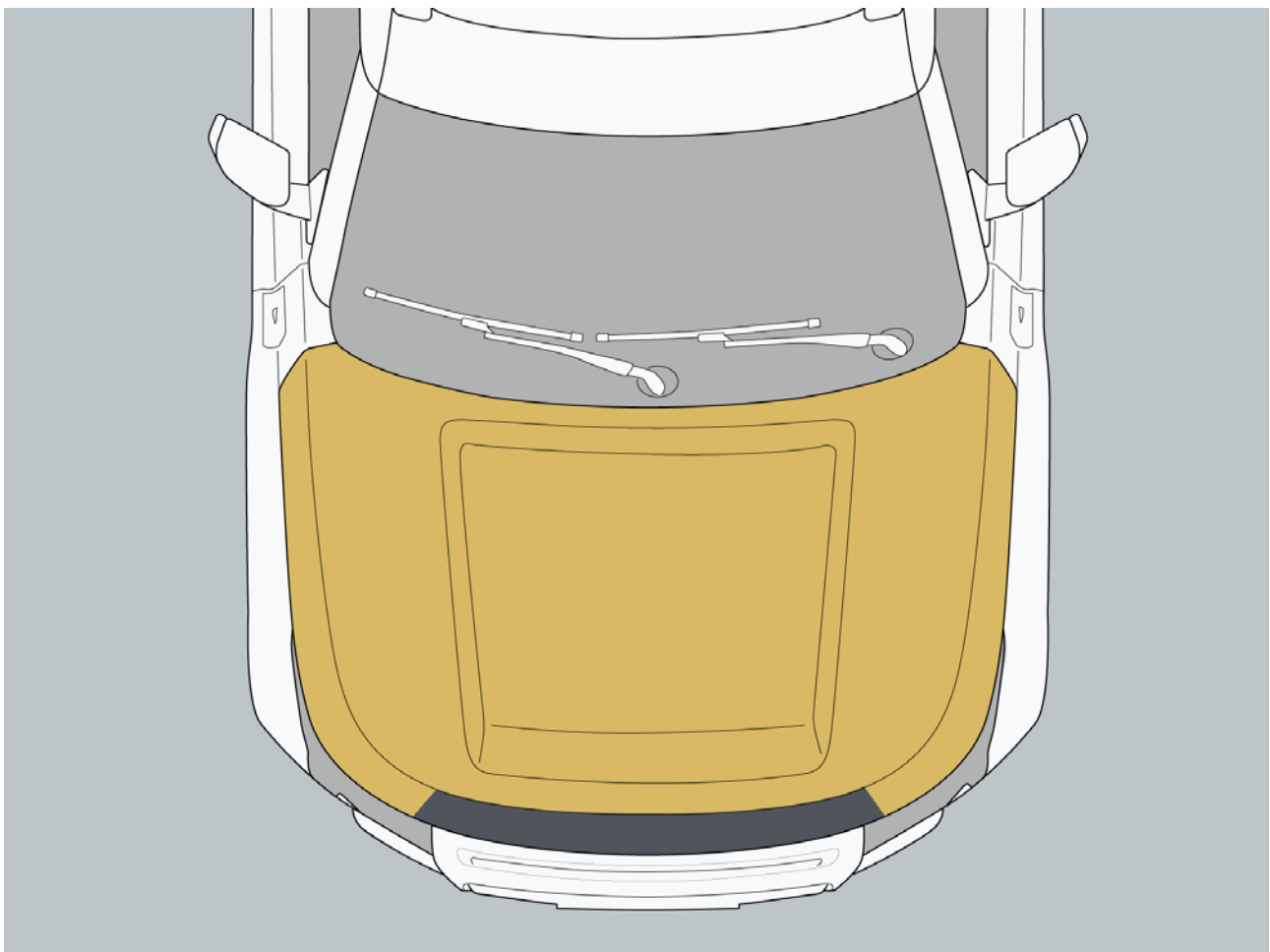

8.3.2 Engine room

I. Location of oil/fluid filling port

S/N	Name
1	Cleaning solution filter port
2	Power battery coolant filling port
3	Engine oil filling port
4	Brake fluid filling port
5	Range extender coolant filling port

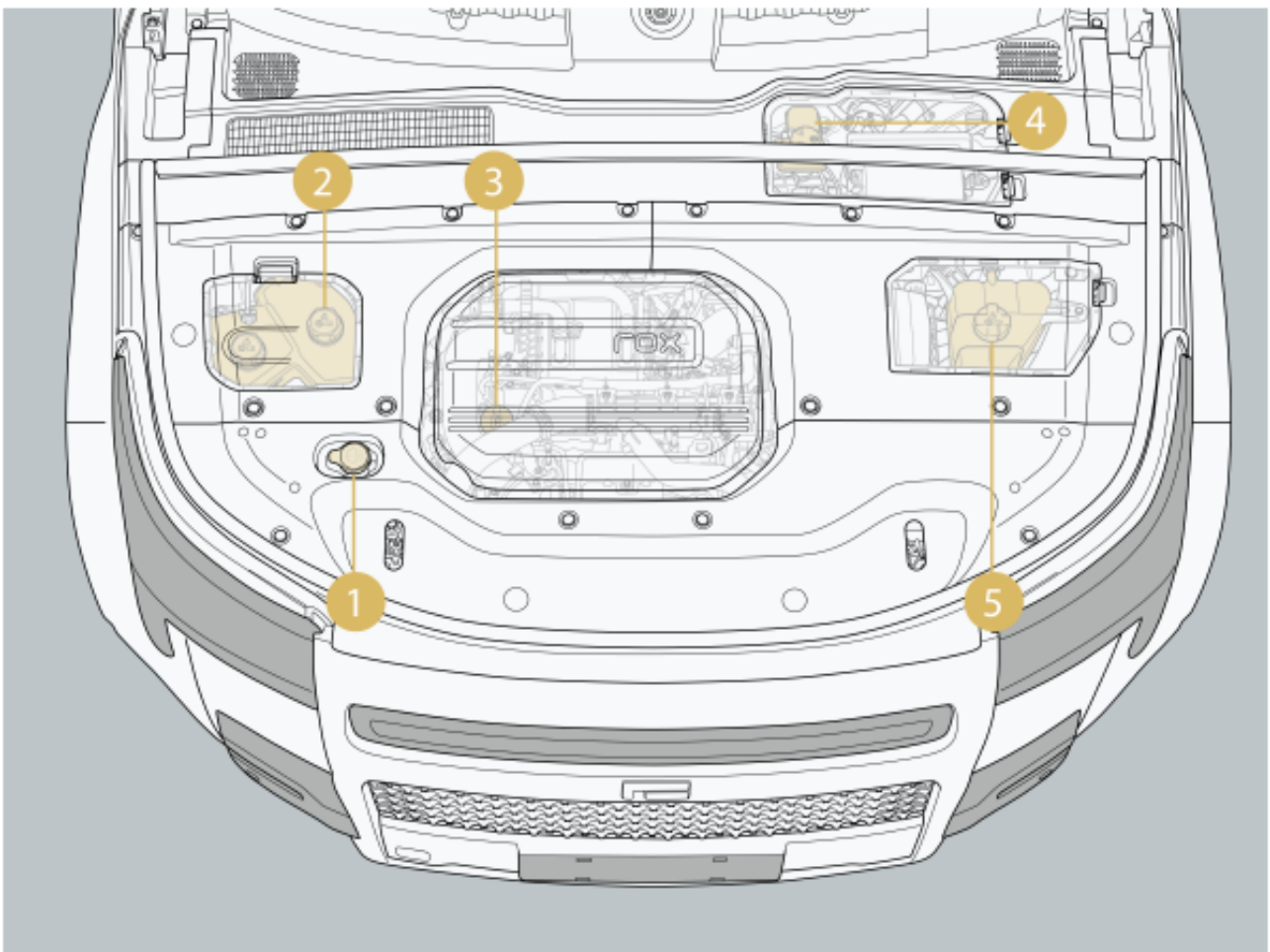

Warning

- Do not open the range extender, drive motor and power battery integrated expansion water tank cap immediately after driving the vehicle to avoid burns.
- Do not place flammable materials such as paper or rags inside the engine compartment.
- Do not get close to parts that may move, such as fans and belts, to avoid personal injury or vehicle damage due to hands, clothing, or tools being entrapped suddenly.
- Do not allow the level of oil to be outside the normal filling range.

8 Maintenance and repair

- Do not touch parts inside the engine compartment immediately after driving the vehicle to avoid burns.

8.3.3 Battery

I. Warning sign information

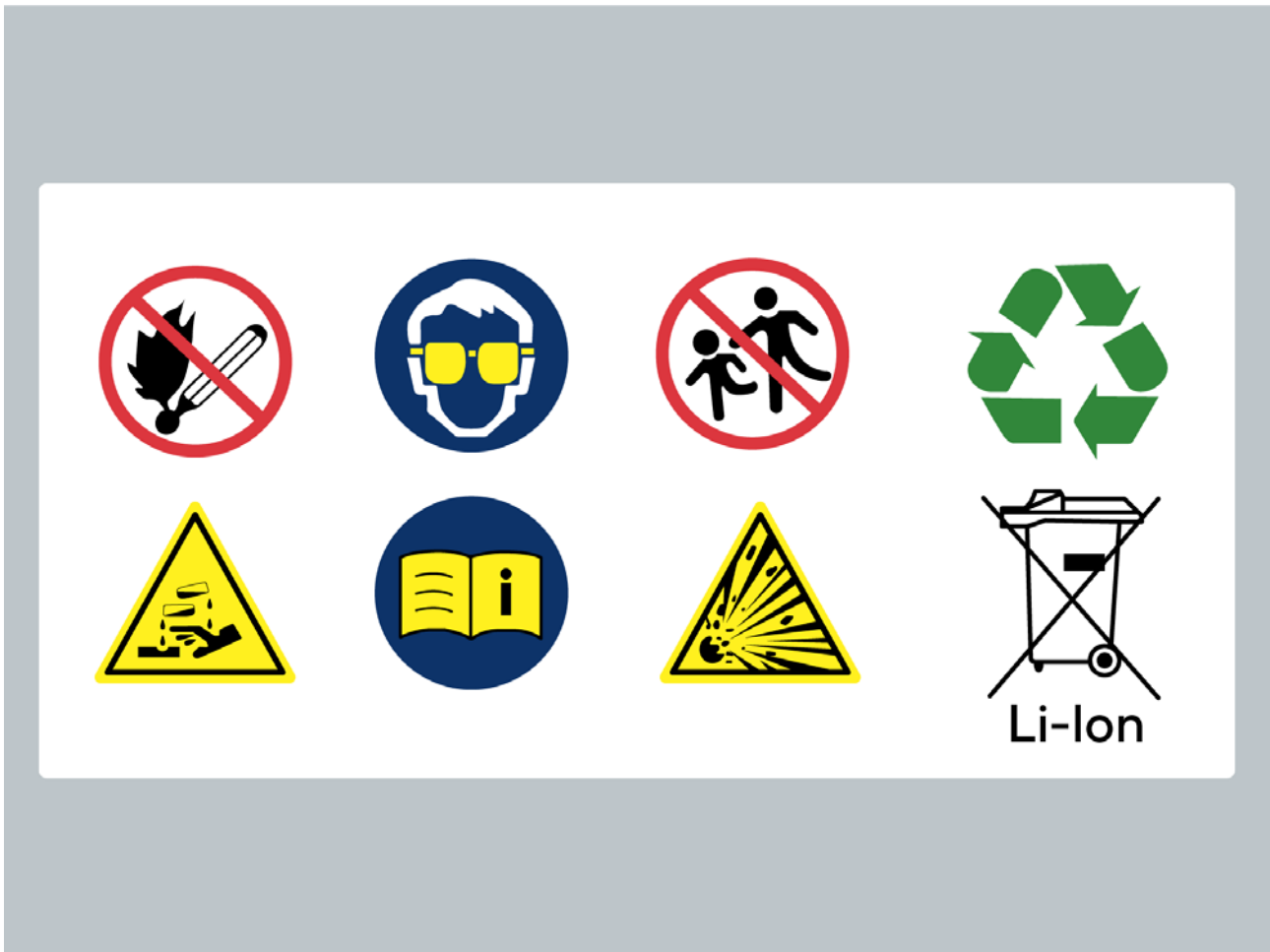

II. Battery position

The battery is located on the left side of the trunk. You can find it by taking out the trunk mat and removing the tool box.

III. When the battery fails

If the battery fault light appears on the instrument panel, it indicates that the battery is low on charge or there is a fault in the battery system. Please contact the ROX Service Center promptly.

Caution

- If a battery failure leads to the battery running out of charge and the vehicle cannot be started normally, please contact the ROX Service Center.
- This vehicle uses lithium-ion battery. Do not connect an external power source to charge the battery, as this may damage the battery.
- Jump starting between this vehicle and another vehicle is prohibited to avoid damaging the battery.

8 Maintenance and repair

- If it needs to replace a battery, contact the ROX Service Center. Do not attempt to replace the 12 V battery by yourself.

8.3.4 Tire

I. Use of tire

To ensure driving safety and comfort, we remind you to read carefully and strictly follow the following precautions when driving your vehicle for the safety of yourself and your family:

- Choose to drive on roads with good conditions.
- During driving, stay focused and avoid obstacles such as bumps or depressions in front of you. If unavoidable, reduce your speed and drive slowly through them.
- Regularly check the tires for damage (such as cuts or cracks) and irregularly check abnormal wear.
- Maintain the correct tire pressure.

II. Tread depth

The tread wear mark is located at the groove of the tire tread and at the shoulder of the tire. When the tread wear reaches the same level as the mark, please replace the tire as soon as possible.

Hint

- When the tire tread becomes shallower, the wet performance of the tire will deteriorate, thereby affecting the vehicle's handling performance in rainy weather.

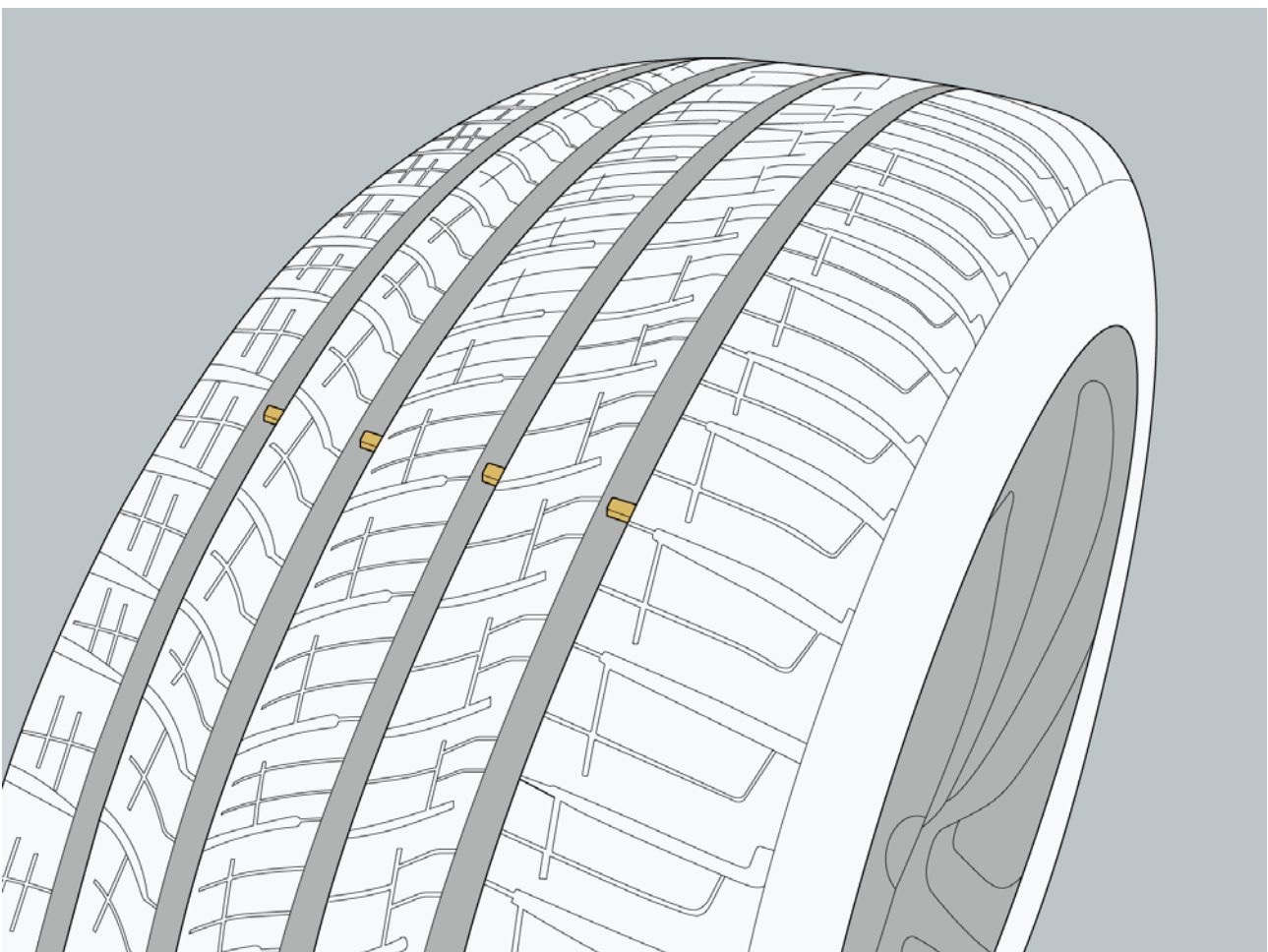

8 Maintenance and repair

III. Tire inspection

For your driving safety, please regularly check the tires for the following, and contact the ROX Service Center for a re-inspection and replacement if any damage or irregularities are found or suspected.

- Check if the tire tread is unevenly worn. Remove any foreign objects from the tread (such as stones, glass, etc.).
- Check if the tread has worn down to the point where the wear mark is exposed.
- Prevent the tires from contacting engine oil, grease or fuel.
- If the dust cover on the tire valve is missing, replace it as soon as possible.

Warning

- Do not use retreaded tires or tires with unknown age.
- The four tires should be of the same model, tread pattern and manufacturer.
- After tire replacement, the tires must be checked for dynamic balance.
- When replacing tires, they must be replaced in pairs. Replacing only one tire will severely affect the vehicle's handling.
- Driving over obstacles quickly, such as hitting curbs or road damage, may cause tire damage. Larger wheels have a smaller tire cross-section. When the tire cross-section is small, the risk of tire damage will increase, and there is a danger of accidents and damage to objects. Try to avoid obstacles or drive slowly and carefully.

IV. Tire storage

After replacing tires, store the unused tires properly:

1. Please make sure to store the tires in a cool, dry place.
2. Tires without rims should be stored upright.
3. Prevent the tires from being contaminated with engine oil, grease, fuel, and solvents.

V. Four-wheel rotation

To ensure even tire wear and extend the tire's service life, it is recommended to rotate the tires every approximately 10,000 km.

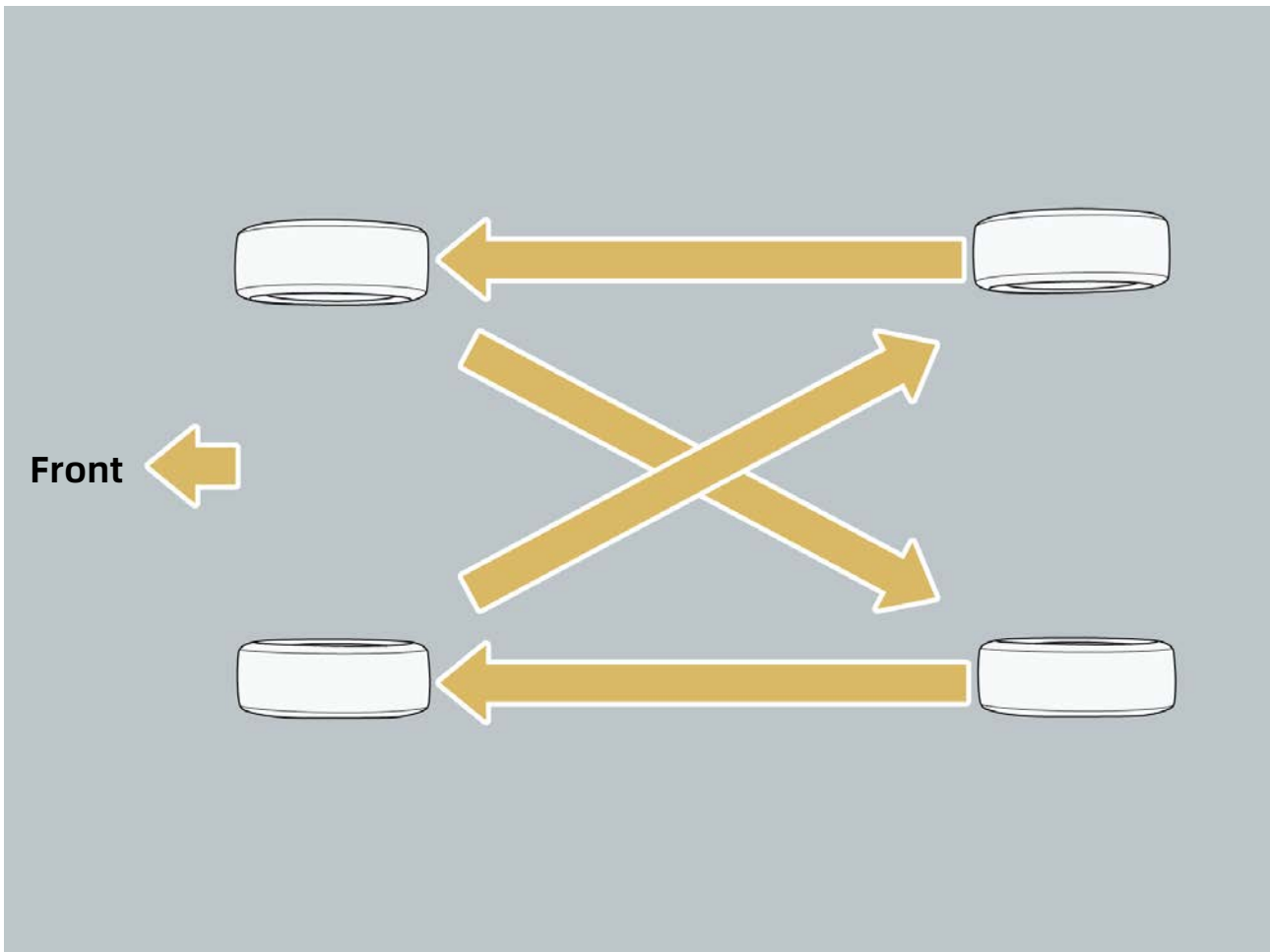

8 Maintenance and repair

8.3.5 Tire pressure

I. Tire pressure label

The tire pressure label is located on the rim of the driver's door, and the tire pressure shown on the label is the cold tire pressure value.

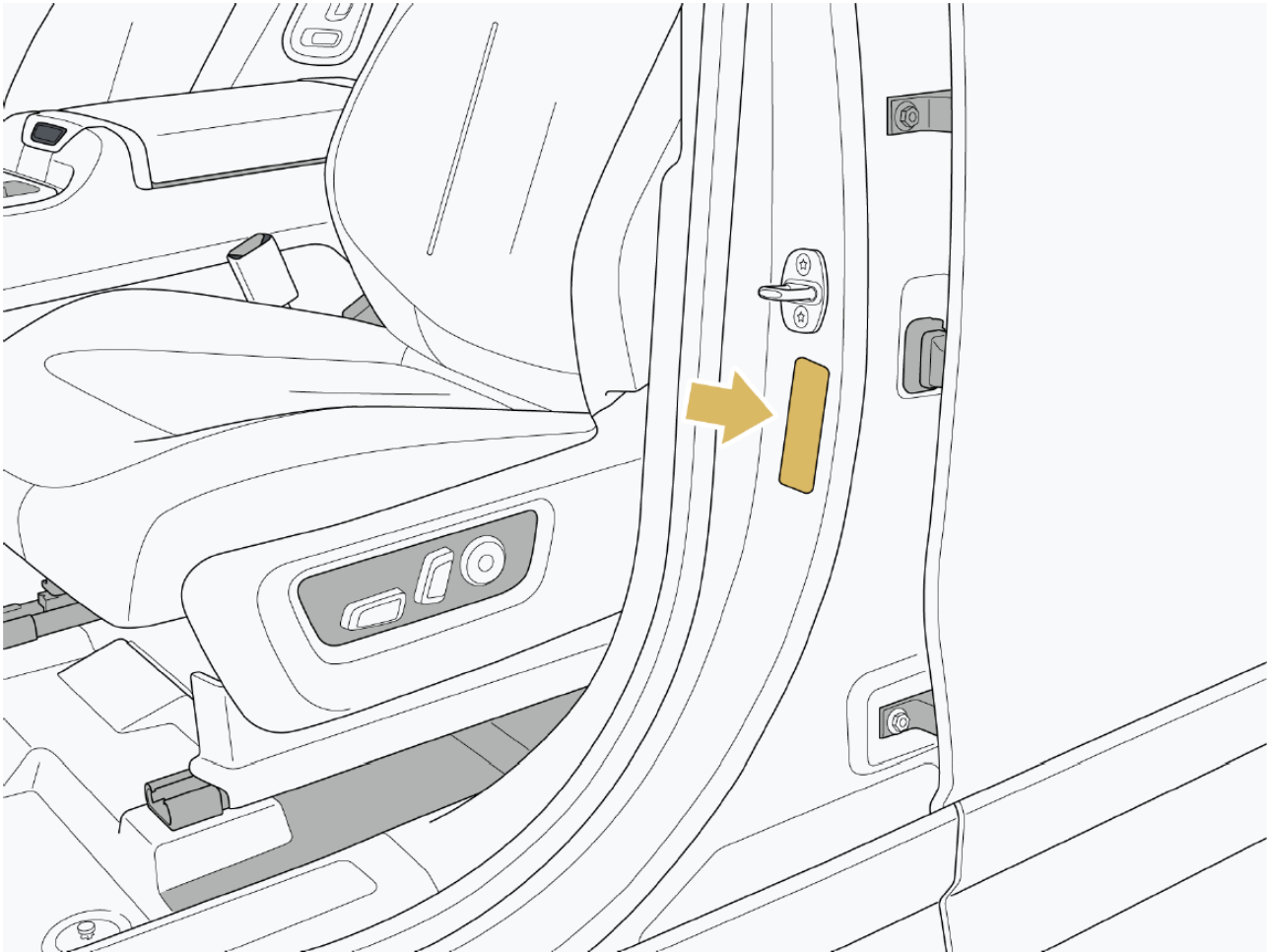

II. Tire pressure check

When checking tire pressure, observe the following:

- It is recommended to check tire pressure at least once a month.
- When checking tire pressure, the vehicle should be parked for at least 3 h or have not driven more than 2 km, as this will allow for a more accurate measurement of the tire's cold tire pressure.
- Tire pressure will be higher than the cold tire pressure when driving, which is a normal phenomenon. Do not check tire pressure after long periods of driving.

III. Abnormal conditions

When tire pressure is abnormal, the following conditions may occur:

- Reduction in driving comfort and maneuverability.
- Uneven tire wear.
- Decreased safety.

Caution

- When a tire deflates, park the vehicle in a safe area and contact the ROX Service Center promptly.

8.3.6 Wheel

When the tires are deformed, cracked, or severely corroded, they should be replaced promptly, as this may affect the vehicle's comfort or lead to loss of control due to wheel failure.

I. Tire selection

When replacing tires, it is important to ensure that the tires to be replaced have the same load capacity and size as the original tires. The ROX Service Center does not recommend using:

- Tires of different specifications or types.
- Tires with an unclear age or date of manufacture.
- Corrected tires.
- Retreaded tires.

II. Tire replacement

1. Always use the wheel bolts specified by ROX or equivalent products designed specifically for aluminum rims.
2. When performing a dynamic balance, please use the balance weights specified by ROX or equivalent products.

Caution

- The repair or replacement of tires may affect the normal operation of the tire pressure monitoring system. Therefore, when you need to repair or replace your tires, please contact the ROX Service Center.
- Make sure to use parts specified by ROX or equivalent in specification.

8.3.7 A/C filter

Check and replace A/C filters regularly according to maintenance plan. If the vehicle is driven in dusty areas or busy traffic areas, it is advisable to shorten the replacement interval for the A/C filter.

If the air flow from the vehicle's air vents is weak or there is an unpleasant odor when A/C is turned on, it may indicate that the A/C filter is clogged or has foreign objects. Check the A/C filter and replace it if necessary.

8 Maintenance and repair

8.3.8 Windshield wiper

Wiper check

1. Contaminants on the windshield or wiper blades can reduce the utility of the wiper blades. Contaminants include ice, car wash spray wax, cleaning solutions containing bacteria and/or waterproofing agents, bird droppings, tree sap and other organic substances.
2. Check if the wiper blades are worn or broken.
3. Check if there is any unusual noise when the wiper blades are in operation.

Wiper maintenance

1. If the wiper blades are not working properly or show signs of wear, clean the windshield and wiper blades with mild detergent, then rinse with clean water and replace them as needed.
2. Only use cleaning products that are certified for use on automotive glass and rubber. Improper use may cause damage or contamination, leading to glare on the windshield.

Caution

- Do not use the wipers when the windshield is dry or when the wash pot is empty.
- Before turning on the windshield wipers, thoroughly defrost and clear the snow from the windshield.
- Before washing the car, ensure that the windshield wipers are in the off position.
- Allowing the wiper arm to contact the windshield without a wiper blade installed may damage the windshield. Any damage resulting therefrom is not covered by the vehicle warranty. Do not allow the wiper arm contact the windshield.

Wiper replacement

1. After lifting the wiper arm, place a thicker towel under the lower part of the wiper arm against the windshield to prevent the wiper arm from accidentally bouncing back and damaging the windshield.
2. After lifting the wiper arm, press the locking clips on the left and right sides of the wiper, then pull out the wiper forward.
3. After replacing the wiper, gently place the wiper arm back on the windshield.

Hint

- The replacement method for the wiper on the left and right sides is the same with the rear window wiper.

8.3.9 Remote-control key battery

When the battery power is too low or exhausted, replace the battery with a new one. Otherwise, some functions of the remote key will be restricted (e.g., starting the system, remote control functions cannot be used normally, etc.).

I. Replace the battery

1. Use a slotted screwdriver to reach into the disassembly opening and pry the key panel component upwards.

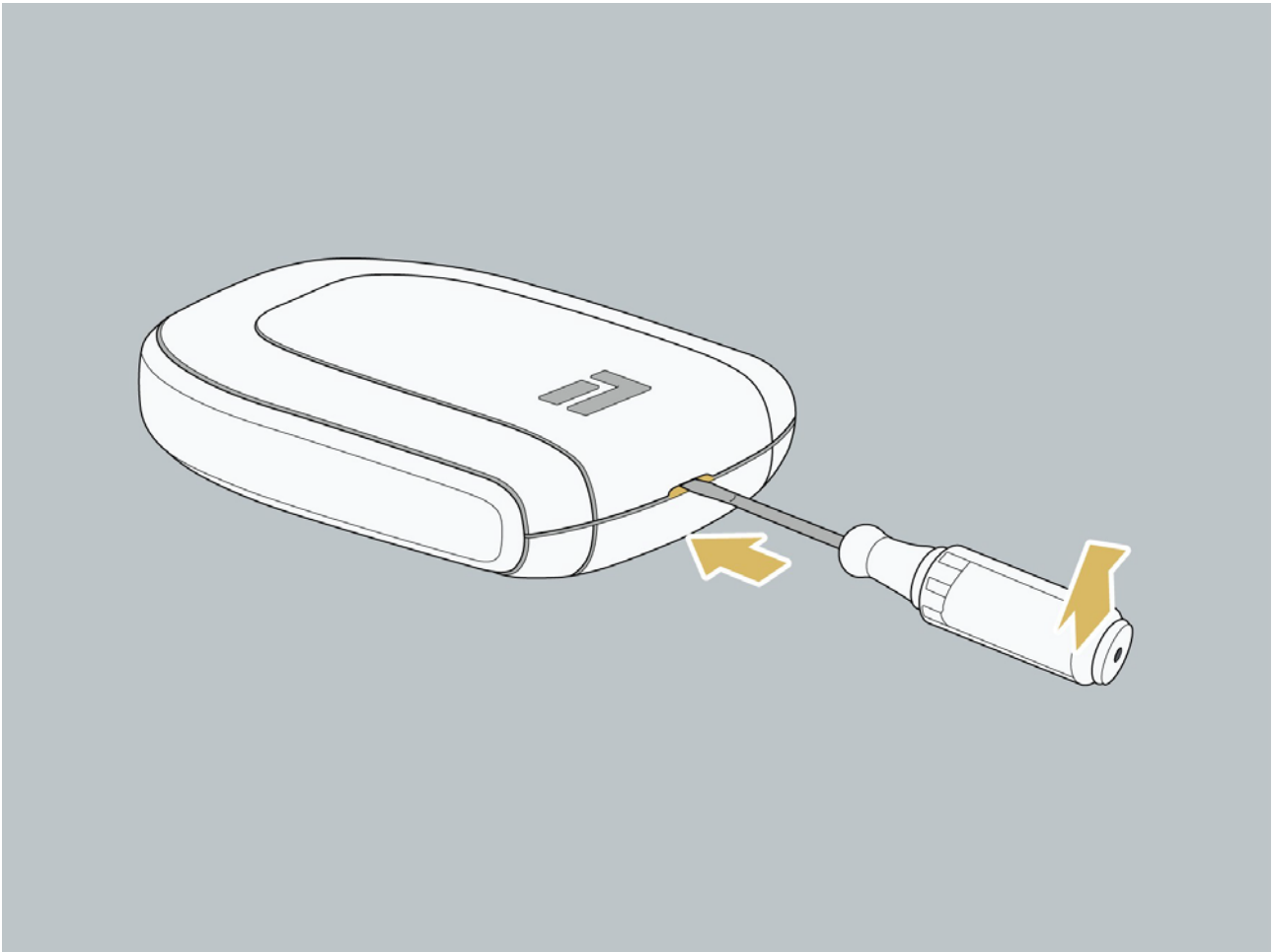

8 Maintenance and repair

2. After separating the panel component, pry out the button battery along the gap in the battery compartment, and install it with the positive terminal facing upward.

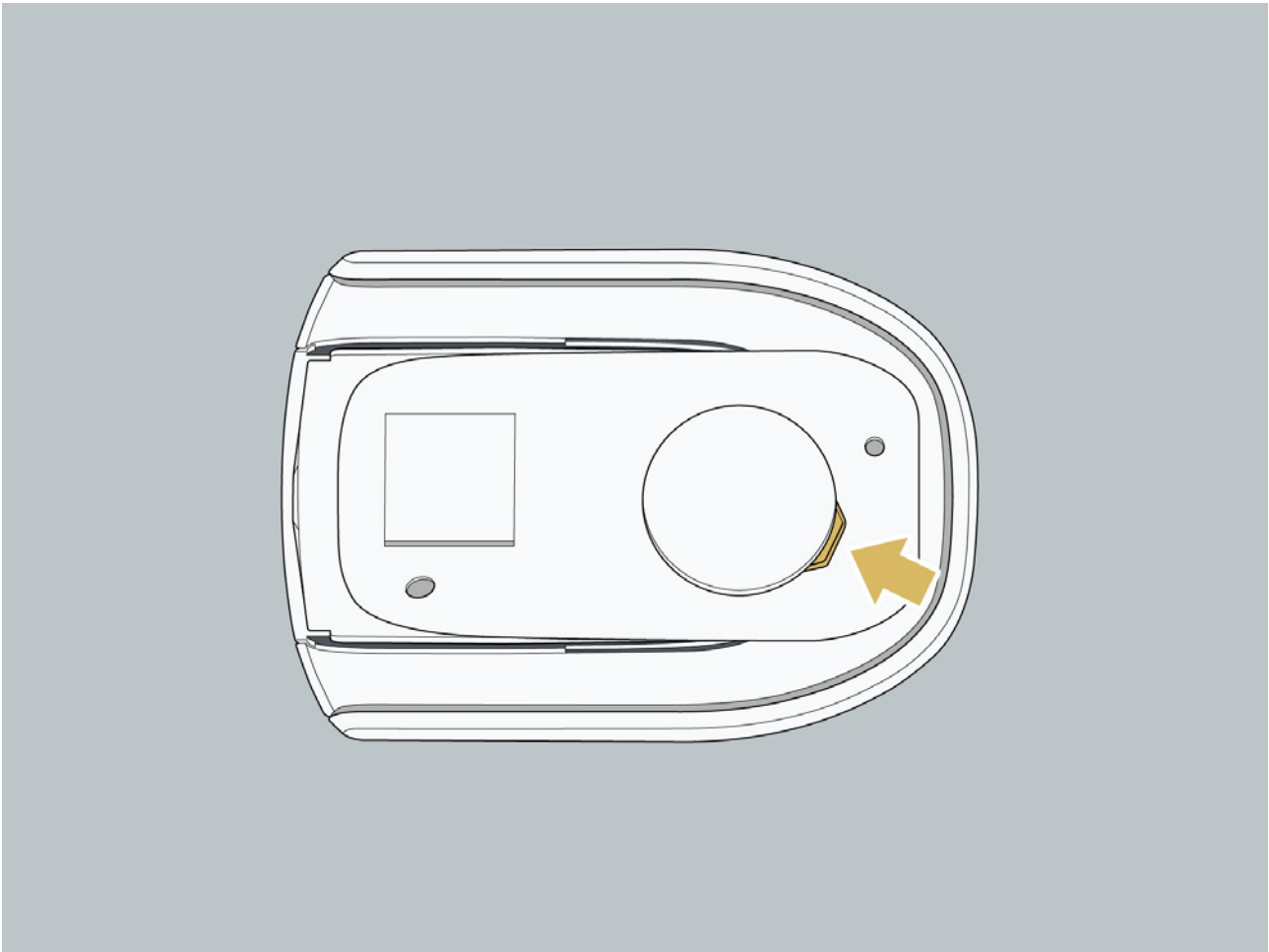

3. After the battery is installed, assemble it in reverse order of the disassembly steps.

Warning

- Place the battery in a location where children cannot reach to prevent accidental swallowing it.
- When installing the battery, avoid sweat or water on your hands to prevent the battery from rusting and damaging the remote key.

Hint

- When the battery needs to be replaced, it is recommended to have a professional from the ROX Service Center replace it.
- Button Battery (model: CR2032).

Eco-friendly

- The battery contains toxic substances and corrosive materials. Please dispose of the exhausted battery at a qualified professional service center or recycling outlet for used batteries.

8.3.10 Check and replace the fuse

Fuses protect automotive electrical equipment by preventing overload in the circuit. A fuse that has blown indicates that the circuit it was protecting has a fault and is no longer working.

If a fuse is damaged, please contact the ROX Service Center to replace the damaged fuse promptly.

Warning

- Do not use conductor or other conductive items as substitutes for fuses, as they may not melt in time, leading to circuit damage or even a fire.
- Do not modify the fuse or fuse box.

8 Maintenance and repair

8.4 Vehicle long-term parking

8.4.1 Vehicle long-term parking

I. Parking place

When the vehicle needs to be parked for a long period, try to park on a flat road. It is recommended to park in a dry, well-ventilated environment away from sources of heat and corrosive substances, and to use a car cover. This helps slow down the aging of rubber parts and paintwork.

II. Ambient temperature

To maintain the vehicle's good performance, avoid exposing the vehicle to an environment above 55°C or below -30°C for more than 24 h.

III. Battery

When the vehicle detects that the battery power is too low, the intelligent charging function is triggered, and the battery will be charged through the power battery. Therefore, when the vehicle is restarted after being parked for a long time, the remaining range displayed on the central control screen will decrease, which is a normal phenomenon.

IV. Power battery

- Before the vehicle is parked for a long time, confirm that the power battery's charge is within a relatively sufficient range (50% ~ 70%).
- The vehicle must be maintained at least once every three months. It is recommended to charge the battery to 50%~70% with slow charging before parking. If it exceeds three months, the power battery charge needs to be charged up to 70%, and then the vehicle can be parked.
- Before using the vehicle again after it has been parked for more than three months, please check the instrument panel for any battery alarms. If any, please contact the ROX Service Center.

Hint

- For vehicles that are not used for a long time, regular maintenance is essential to prevent irreversible battery damage.
- We recommend that you check the battery charge every week and drive the vehicle once a month. If the battery charge is insufficient, please arrange for a charge before parking it.
- If the vehicle is continuously parked and not used for more than 3 months without regular maintenance of the power battery by following the manual's instructions, it will not be covered by the warranty.
- If the mobile APP is frequently used to remotely control the vehicle during long-term parking, it will increase the power consumption of the vehicle and accelerate power loss. Users should shorten the vehicle maintenance cycle and avoid long-term parking under low battery conditions.

8 Maintenance and repair

- When the power battery's charge is too low, the system will remind the user to charge the power battery through the APP.
- In the event of the vehicle being submerged in water due to weather or special reasons, do not turn on the vehicle's power, as this may cause safety risks or secondary damage to the vehicle.
- Avoid vehicles wading over long distances or for long periods of time.

9 In case of fault

9.1 Measures to be taken in case of emergency

9.1.1 On-board tools

The on-board tools are located in the trunk toolbox (subject to the actual vehicle configuration):

Caution

- The driver must be familiar with the location and usage method of the on-board tools to cope with emergency situations.
- After using the on-board tools, make sure to put them back in the designated place and secure them firmly. Placing them randomly may easily cause accidents.
- The attached jack is a dedicated tool for the vehicle. It is prohibited to use the jack of this vehicle on other vehicles, and vice versa.

9 In case of fault

S/N	Name	S/N	Name
1	Towing hook	2	Wheel wrench
3	Spare tire housing removal wrench	4	Warning sign
5	Jack rocker	6	External discharger
7	Jack		

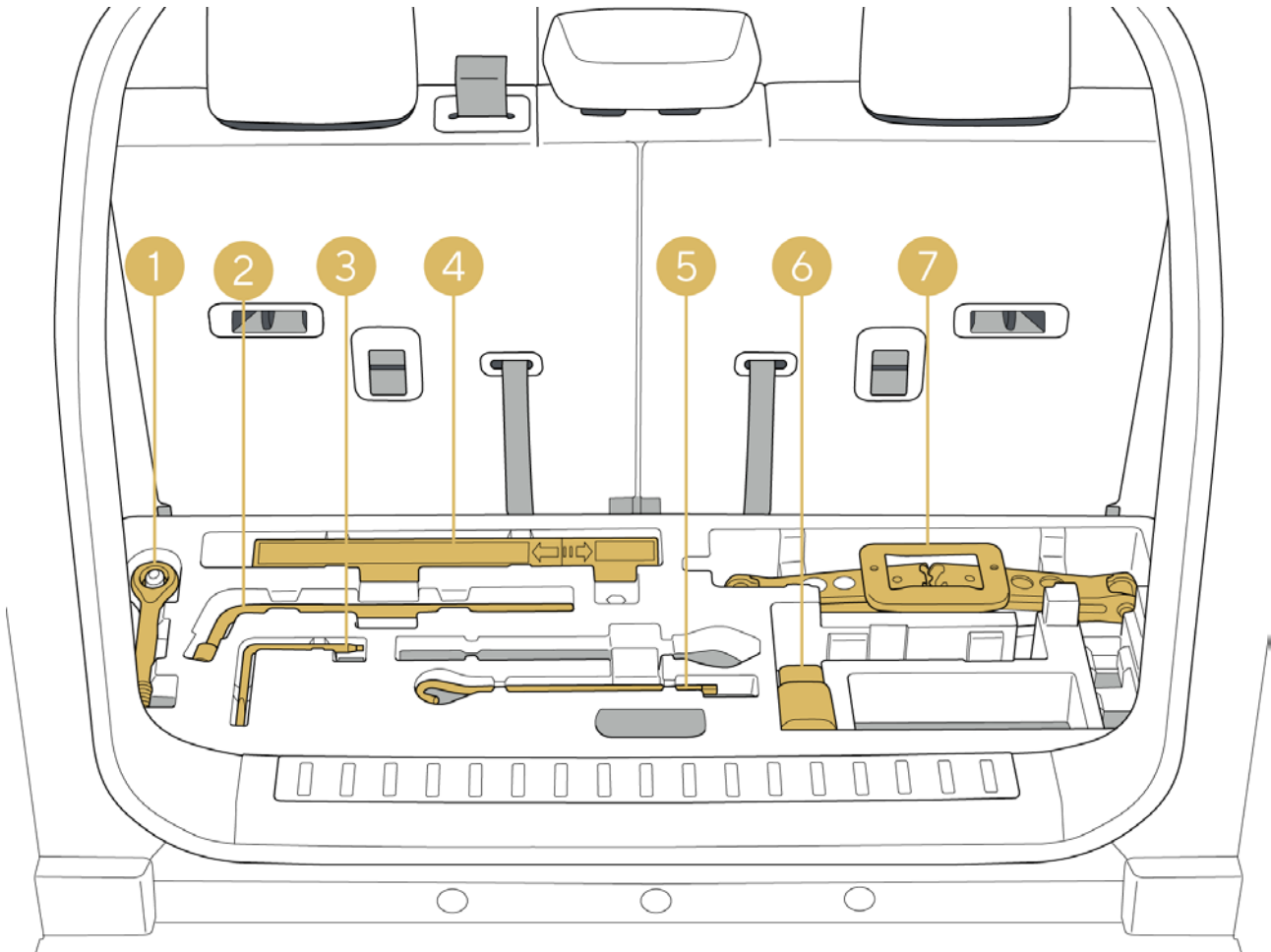

9 In case of fault

9.1.2 Hazard warning lamp

I. Hazard warning light switch

Press the hazard warning light switch, and all turn signal lamps and the turn signal indicators inside the instrument panel will flicker simultaneously.

i Hint

- Press the switch again to turn off the hazard warning lights. The hazard warning lights will work regardless of the vehicle's power mode. If the vehicle power is in the "OFF" mode, please turn off the hazard warning lights to avoid draining the battery.

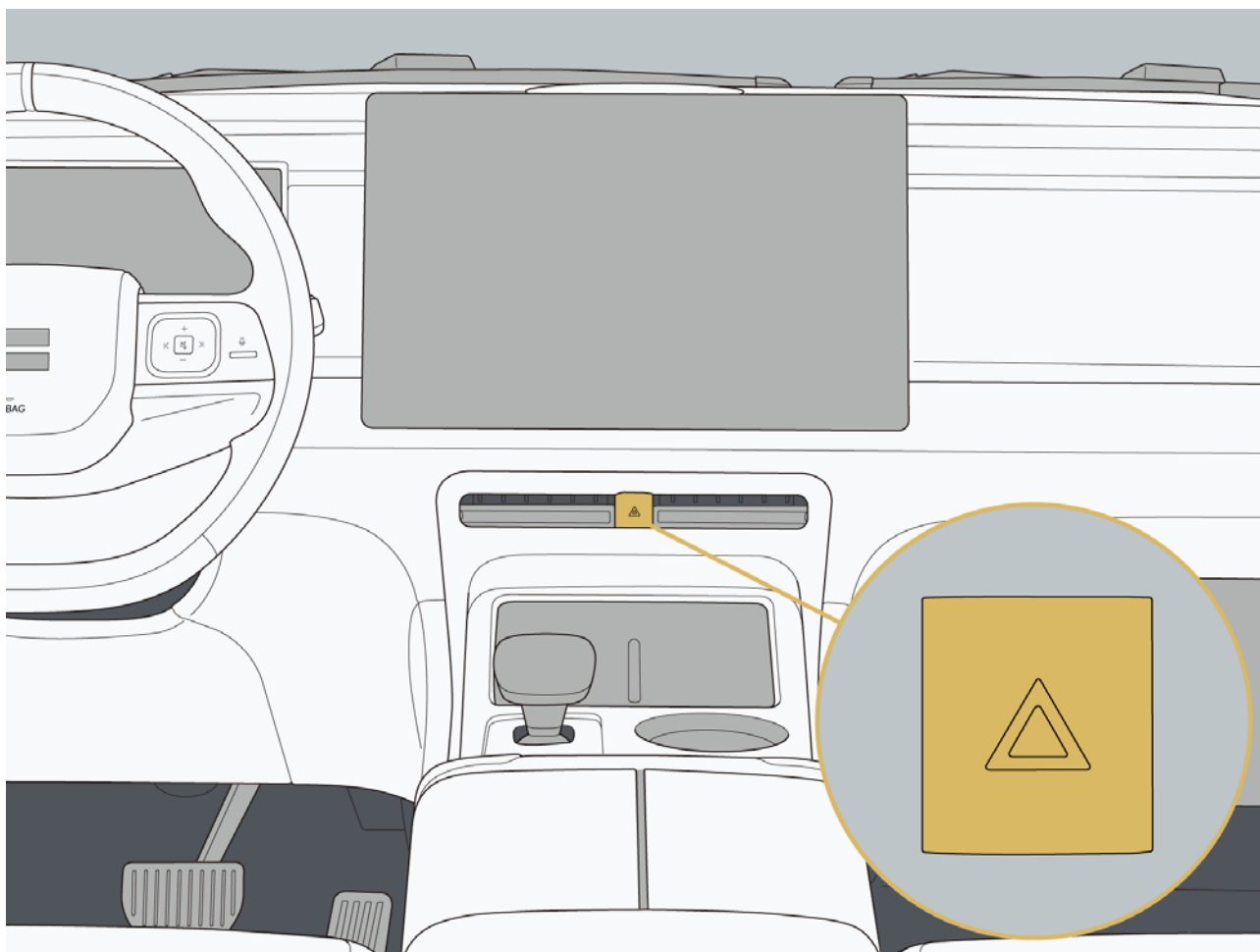

II. Emergency braking triggering hazard warning light

When the vehicle is in motion and an emergency brake is applied, the hazard warning lights will be triggered.

Hint

- After the emergency brake hazard warning lights are triggered and the vehicle has stopped, they can be manually turned off or will automatically turn off when the vehicle is driven at a speed greater than 20 km/h.

III. Collision triggering hazard warning light

After a vehicle collision, the hazard warning lights will be triggered. To turn off them, press the hazard warning light switch.

9 In case of fault

9.1.3 Reflective vest

When dealing with vehicle faults at night or in low visibility conditions, take the reflective vest from the glove box, wear it properly, and then handle the vehicle. This can draw the attention of other drivers and enhance safety.

Warning

- When handling vehicle accidents, it is essential to wear the reflective vest as required to draw the attention of other drivers.
- If the vehicle is involved in an accident and parked on the side of the road, passengers should stay away from the parked vehicle while waiting for assistance to avoid secondary rear-end accidents.

Caution

- If the reflective vest is damaged or extremely dirty, it is recommended to replace it with a new one.

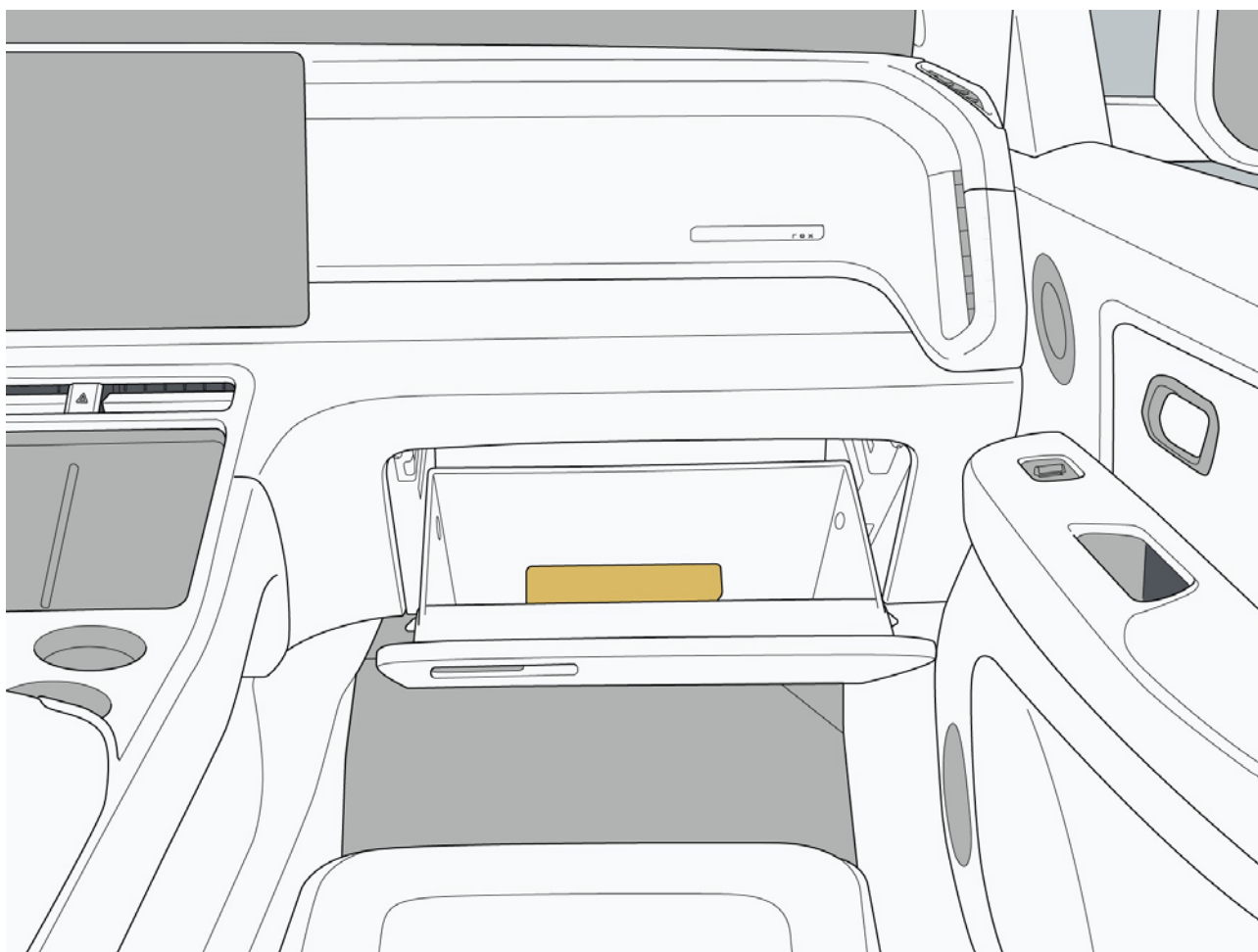

9.1.4 Warning sign

The triangular warning sign is stored in the trunk toolbox.

If the vehicle breaks down, take out the reflective vest from the glove box, wear it properly, and then place the warning sign behind the vehicle at a distance of 50 m to 150 m according to the road section, and turn on the hazard warning lights to warn the vehicles behind.

9.1.5 Vehicle needs towing

I. Towing hook mounting seat

1. The front towing hook of the vehicle is installed at the lower right of the front bumper. Press the the left side of tow hook cover to open the front tow hook cover.

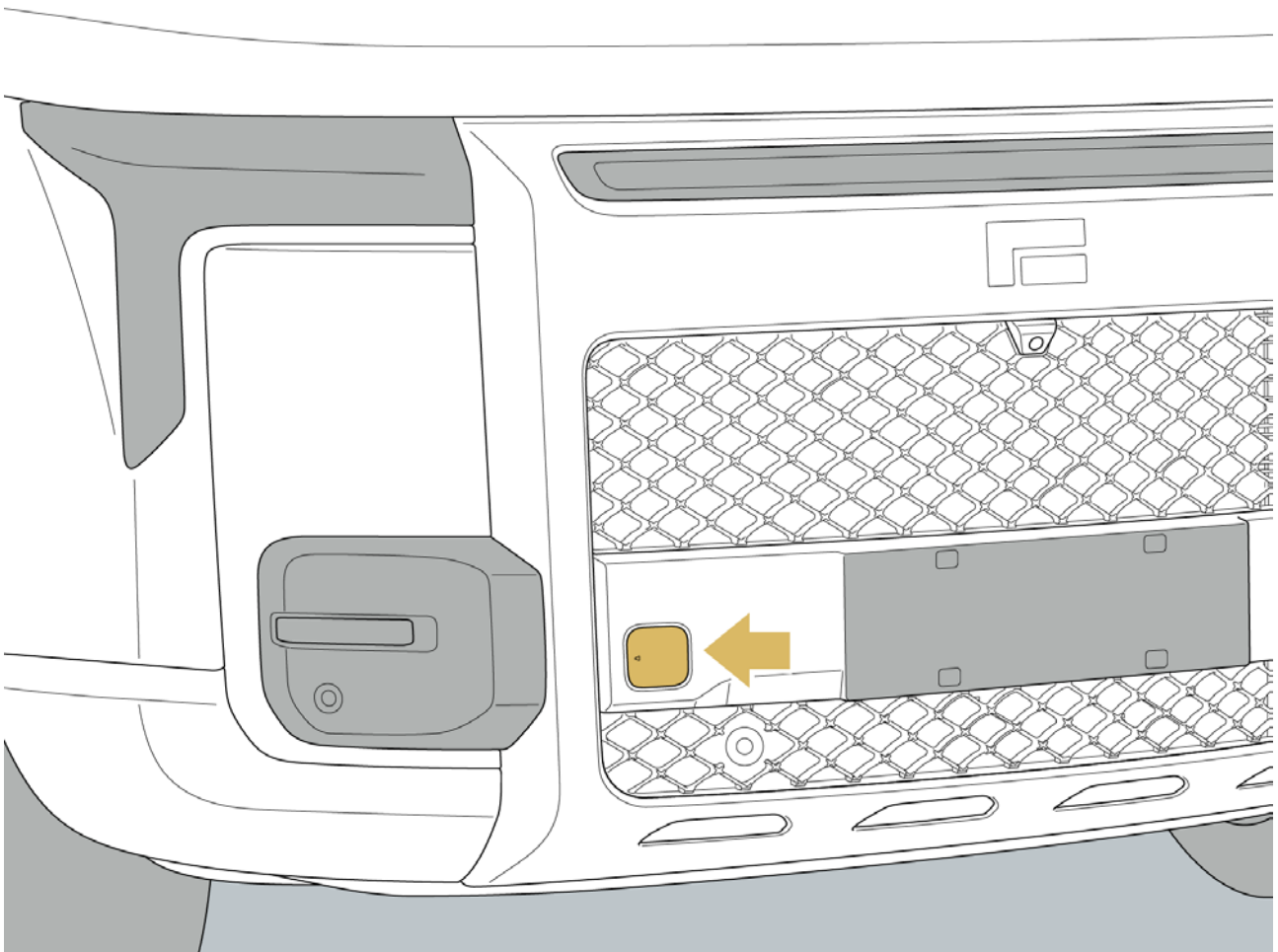

9 In case of fault

2. The rear towing hook of the vehicle is installed at the lower left of the rear bumper. Press the the left side of tow hook cover to open the front tow hook cover.

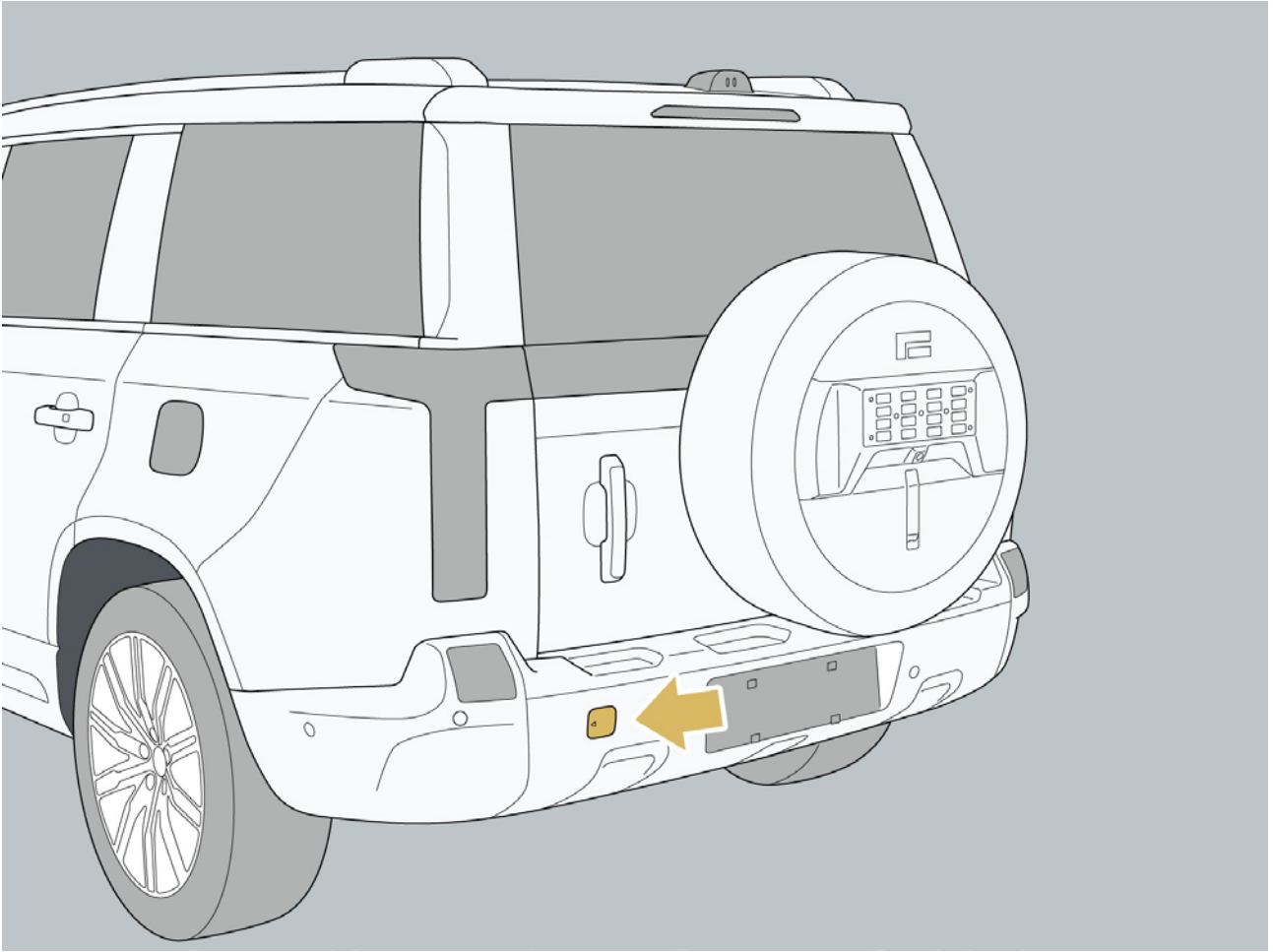

This vehicle is not suitable for towing with wheels landing on the ground. Please do not use the towing chain to directly tow the vehicle.

II. It is forbidden to use the following methods to tow a car:

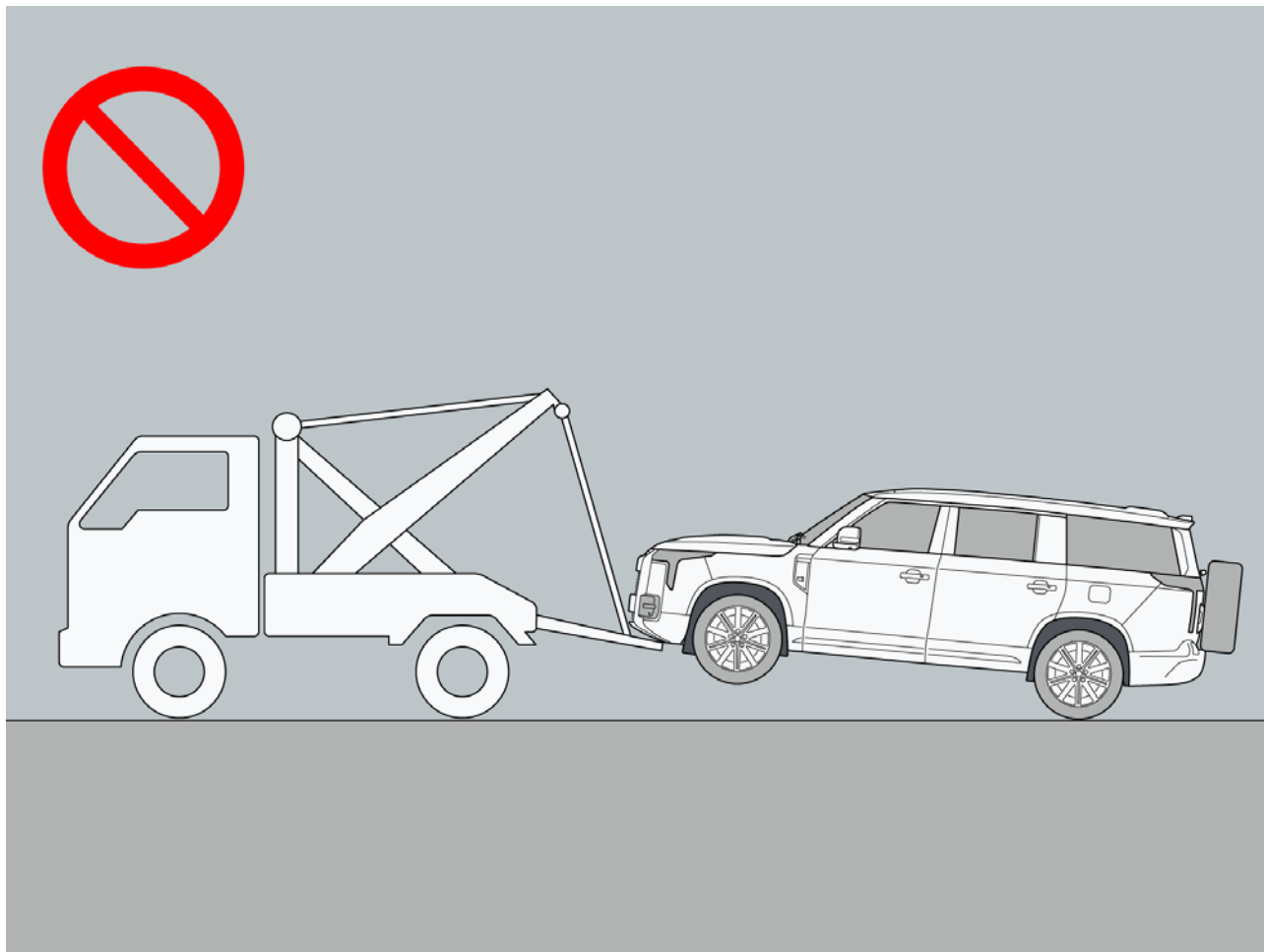

9 In case of fault

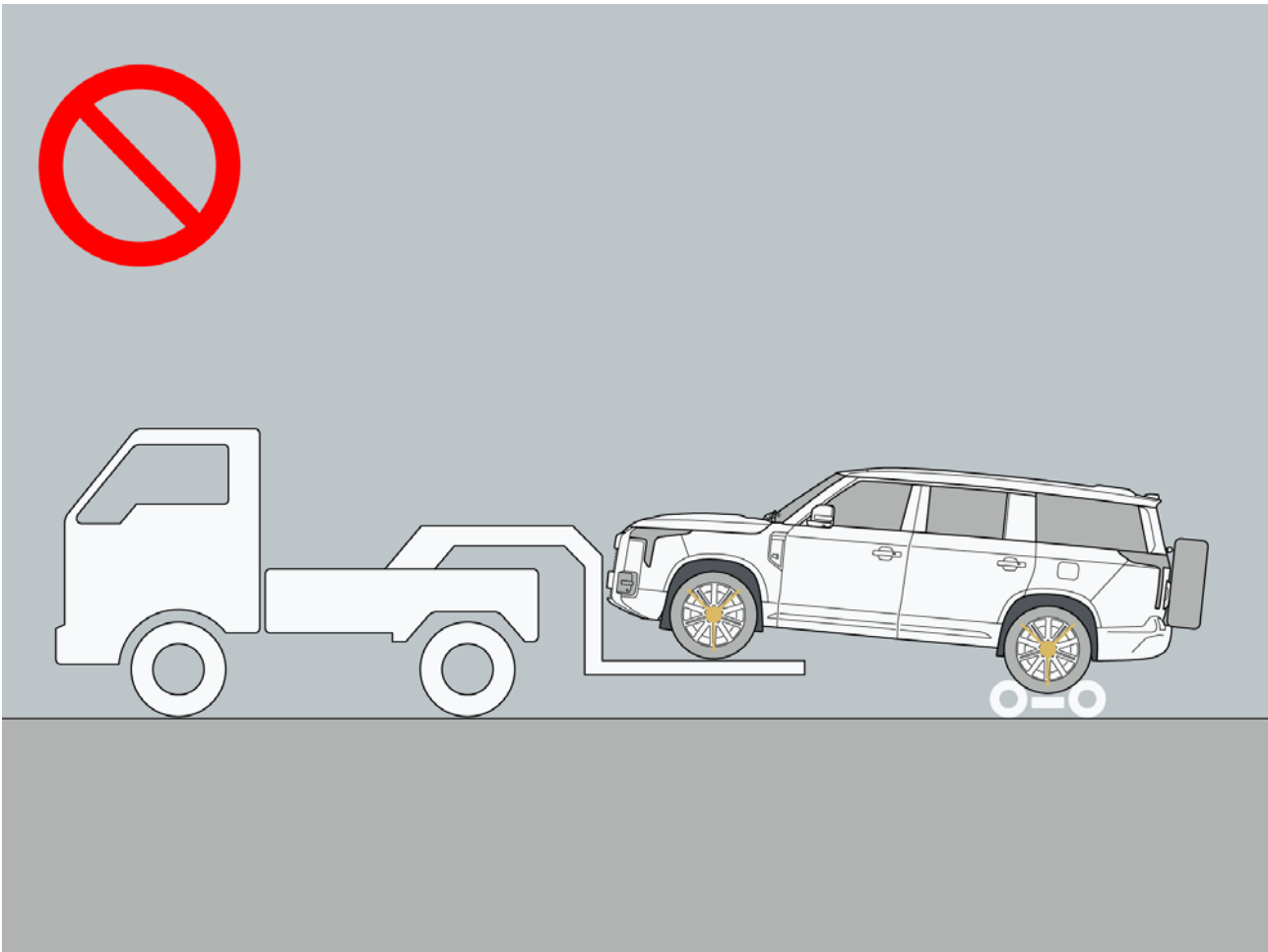

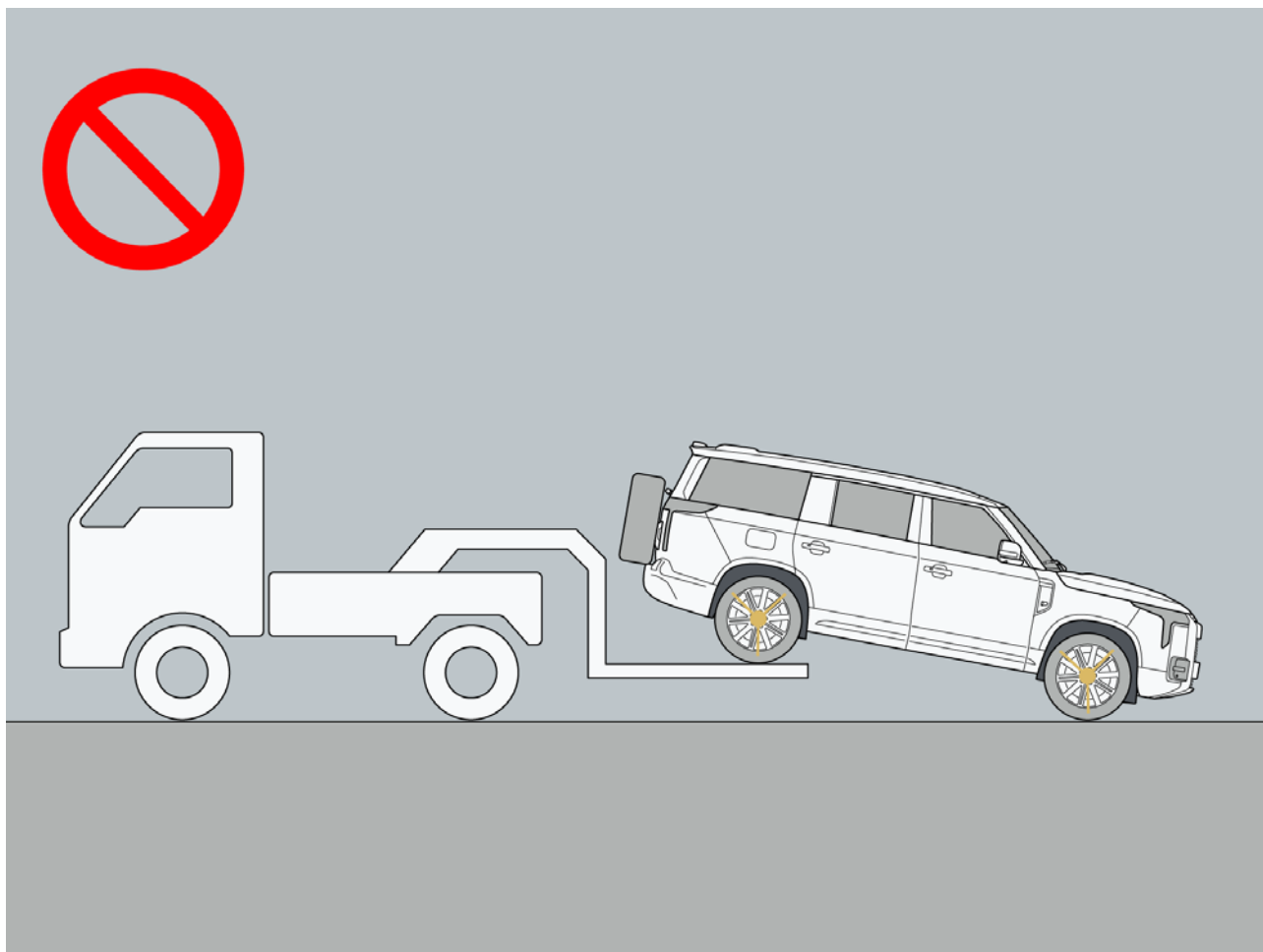

9 In case of fault

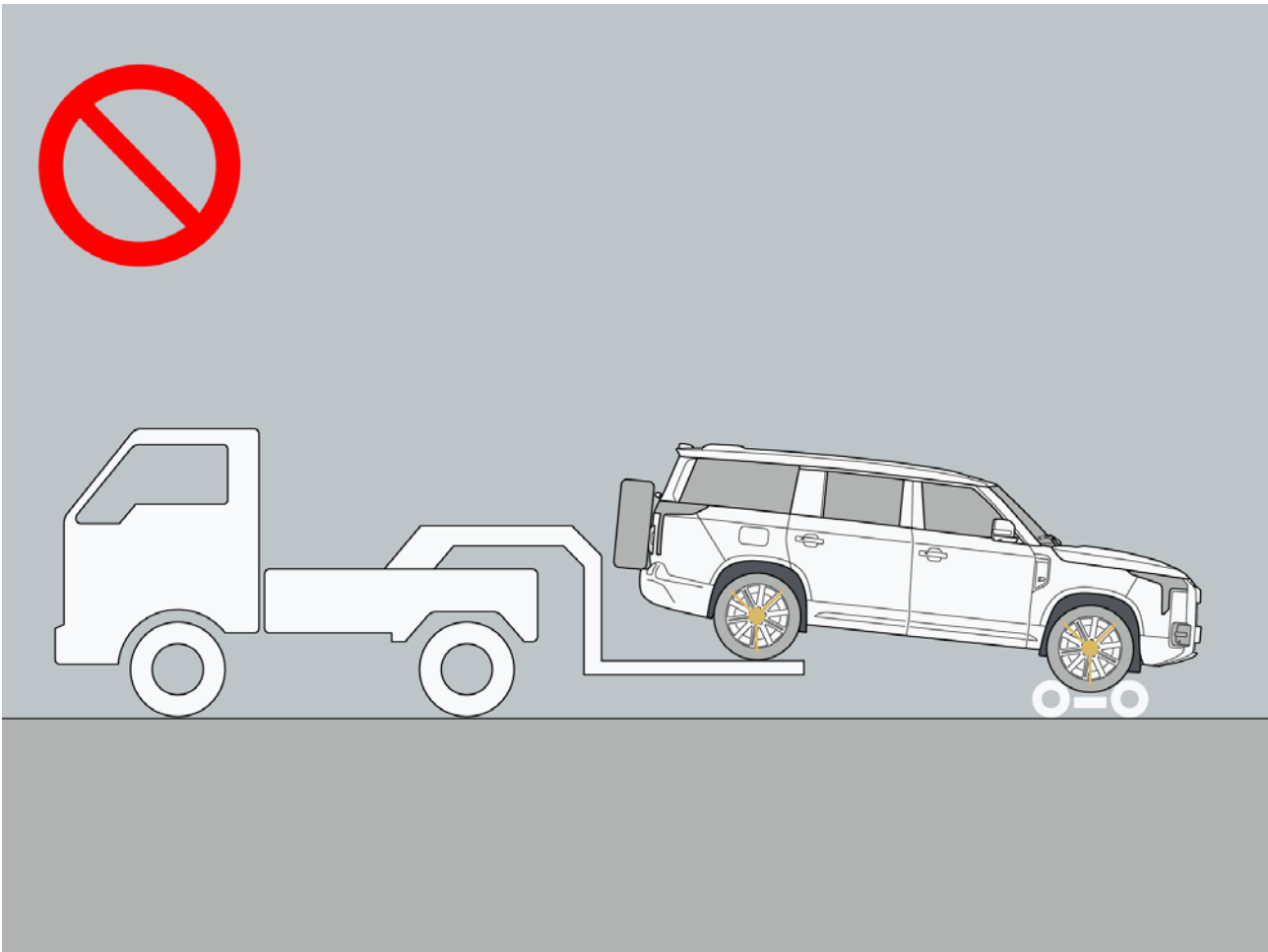

III. The vehicle can only be transported on a flatbed truck.

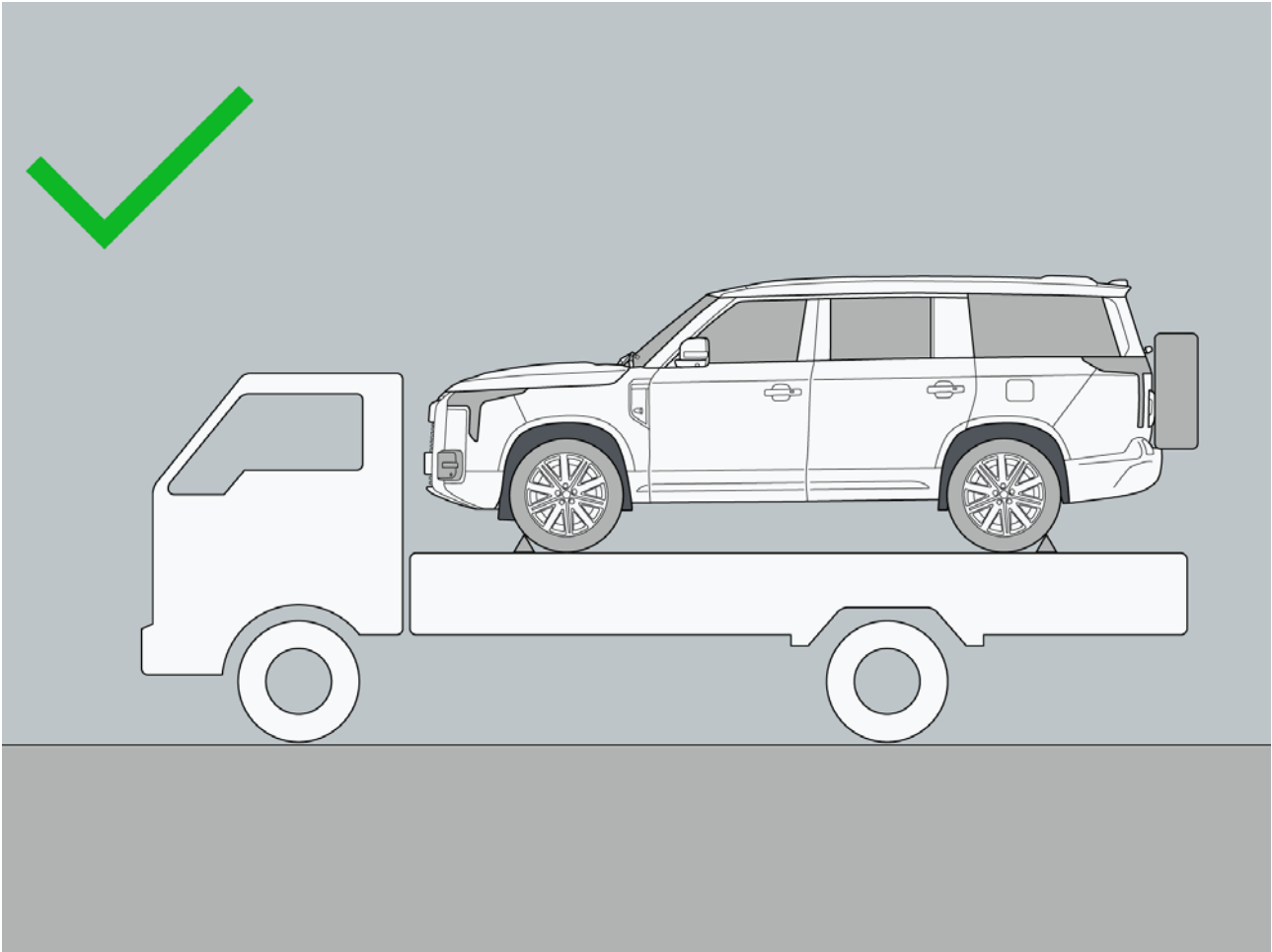

IV. Towing mode

When the vehicle needs to be towed, turn on the towing mode.

Click “Vehicle Settings → Vehicle → Mode” on the central control screen to enable or disable the “Towing Mode” . When the vehicle needs to be towed, open the towing mode. During the activation of the towing mode, the air suspension height adjustment function will be disabled, and there will be system operation noise, which is a normal phenomenon.

To enable the towing mode, the following conditions must be met, otherwise, the towing mode cannot be enabled:

- The vehicle power is not in the “OFF” mode.
- The charger or external discharge adapter is not connected.
- Depress the brake pedal to keep the vehicle in a stationary state.
- The current vehicle gear is in P or N gear.
- The traction mode is in the closed state.

9 In case of fault

Caution

- In the trailer mode usage scenario, it is essential to pay attention to the ground clearance of the chassis.
- After enabling the towing mode, the vehicle will lose its parking ability. Ensure that the vehicle does not slide to avoid safety incidents.
- After enabling the towing mode, the vehicle will not be able to enter the “READY” mode.
- After towing is complete, ensure to exit the towing mode and the vehicle is in a stable state.

V. Emergency towing steps

1. Remove the tow hook from the trunk toolbox.
2. Press the the left side of tow hook cover to open the front tow hook cover.

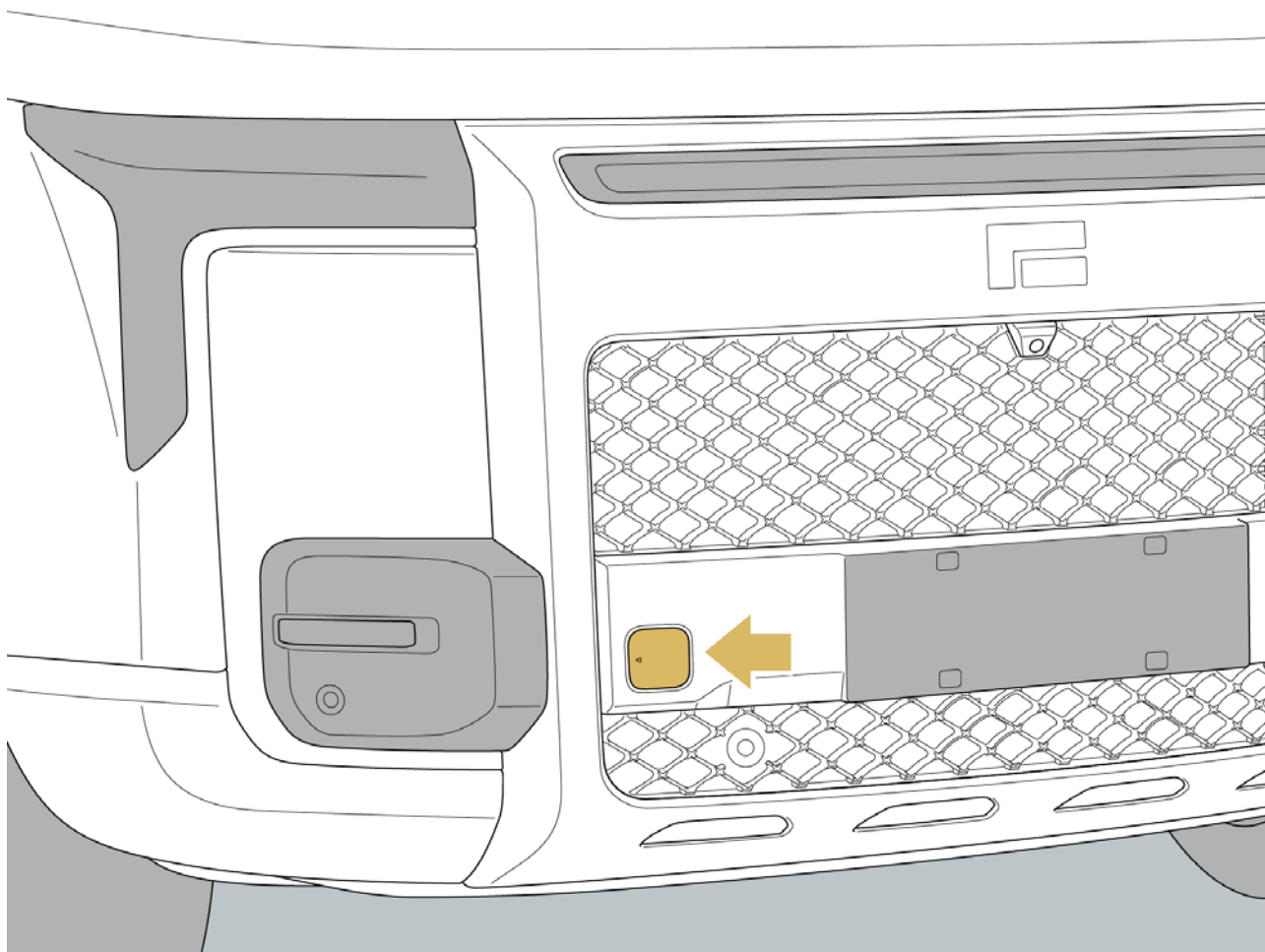

3. Take the tow hook from the trunk toolbox and screw it into the mounting hole in a clockwise direction.

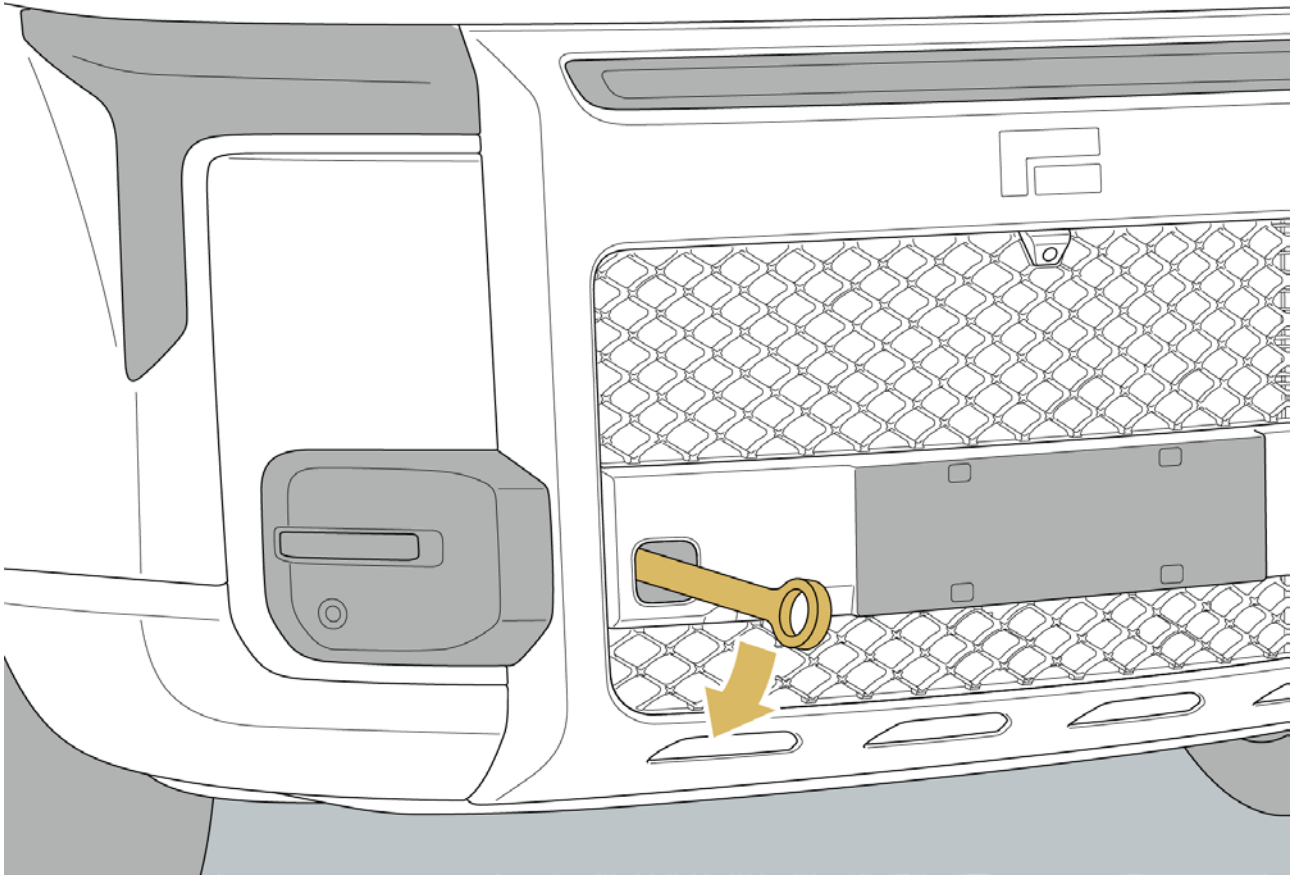

4. Secure the steel cable or safety chain to the tow hook.
5. Enable the towing mode.
6. Have a professional tow the vehicle onto a flatbed tow truck and secure the vehicle.

Warning

- Do not tow the vehicle while the tow hook is not securely installed, to avoid safety accidents.
- When towing the vehicle, do not stand on both sides of the tow rope.
- Only tow the vehicle away from the site when you are sure there is no safety risk. If the vehicle's battery pack is deformed, leaking, smoking, or in a similar state, safety risks should be eliminated first.
- During the towing process, do not turn off the towing mode. After towing onto the flatbed truck, the tires must be secured.

Hint

- The rear towing operation method is the same as the front towing operation method.

9 In case of fault

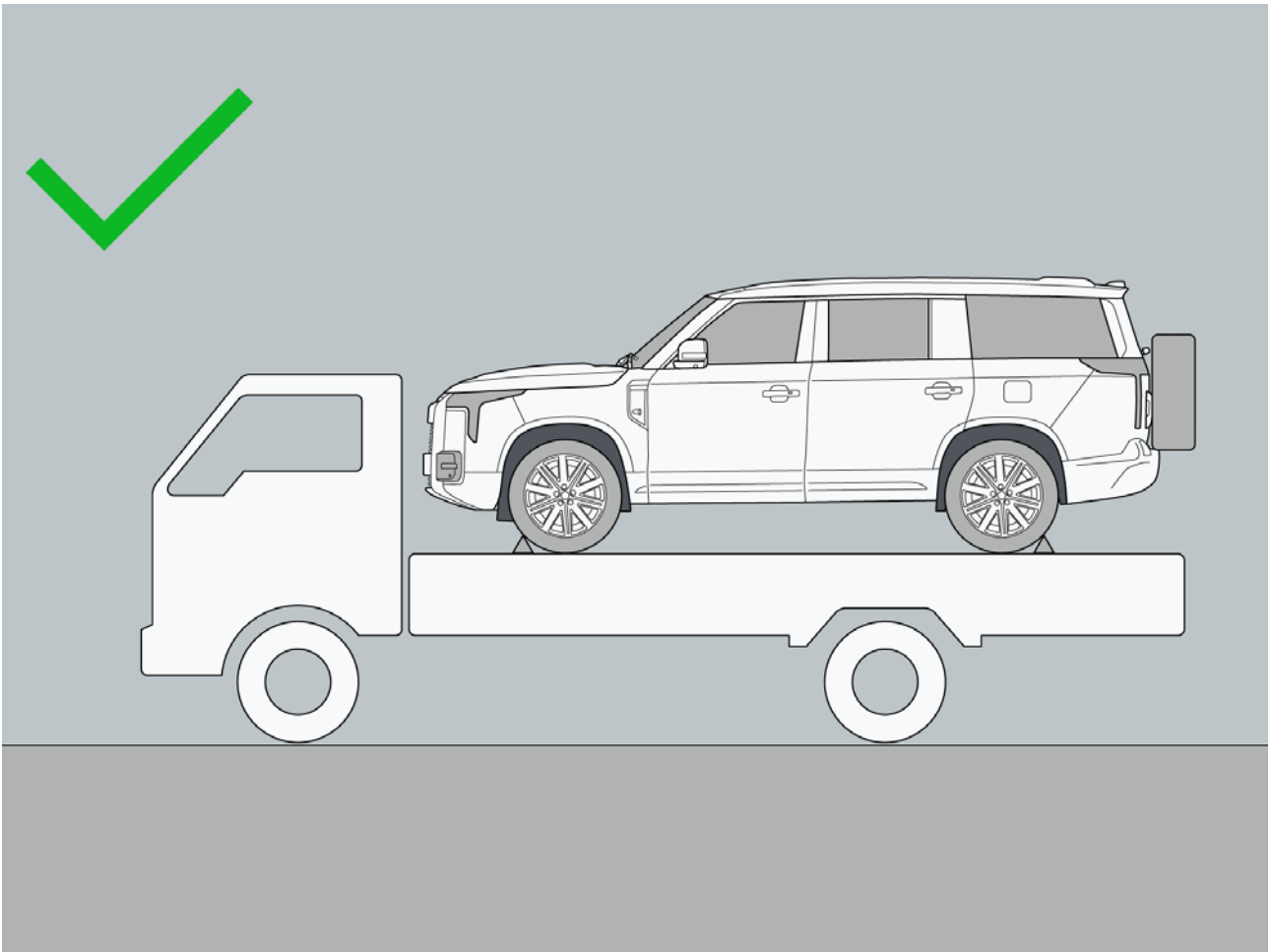

VI. Towing bar (if equipped)

The towing bar can be used for road rescue and off-road rescue (up to 4 tons). If a towing bar is used for off-road rescue, ensure that the driver of the off-road vehicle and the rescue personnel have received training in off-road rescue skills.

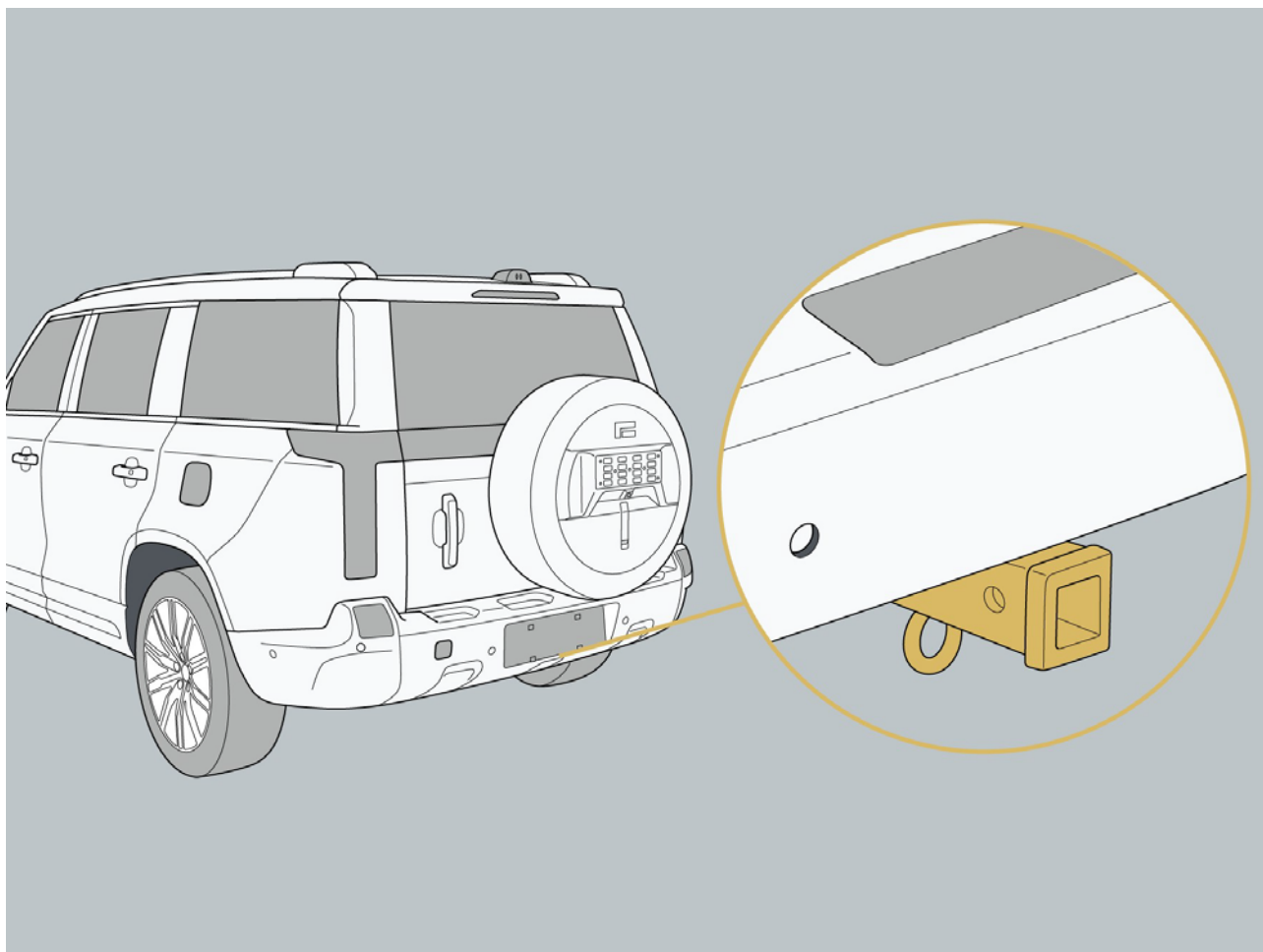

9 In case of fault

9.1.6 Inflation pump

1. Take out the inflation pump from the trunk toolbox.
2. Insert the inflation pump power cord into the 12 V power socket in the storage pot under the control panel.
3. Unscrew the tire valve cover and connect the air hose to the tire valve.
4. Turn on the vehicle power, press the inflation pump power switch to inflate the tire. Observe the tire pressure through the inflation pump pressure gauge. When the tire pressure reaches the specified pressure indicated by the tire pressure label, turn off the inflation pump and turn off the vehicle power.
5. After inflation, place the inflation pump back in the trunk toolbox.

Warning

- Do not continue driving with tire pressure that is too high or too low, to avoid accidents and personal injury.
- Do not continue driving with a flat tire, even for a short distance, as it can cause irreparable damage to the tire and wheel, potentially leading to an accident.

9.1.7 Tire changing operation

During tire change operations, park the vehicle on a safe, hard and flat surface. Switch the vehicle gear to P, enable the electronic handbrake, and switch the vehicle power to "OFF" mode. Turn on the hazard warning lights, wear a reflective vest, and place a warning sign 50-150 m behind the vehicle. Confirm the safety of the vehicle's surroundings before proceeding with the tire change operation.

I. Steps for changing a tire

1. Remove the jack, wheel wrench and spare tire housing removal wrench from the trunk toolbox.
2. Click "Vehicle Settings → Vehicle → Mode" on the central control screen to start the suspension maintenance mode.
3. After taking out the tools, close the trunk. Use a spare tire cover removal wrench to remove the fixing bolts of the external trim panel of the spare tire cover and then take it out.
4. After removing the external trim panel of the spare tire cover, use the tool to remove the fixing bolts of the spare tire cover and remove the spare tire cover.

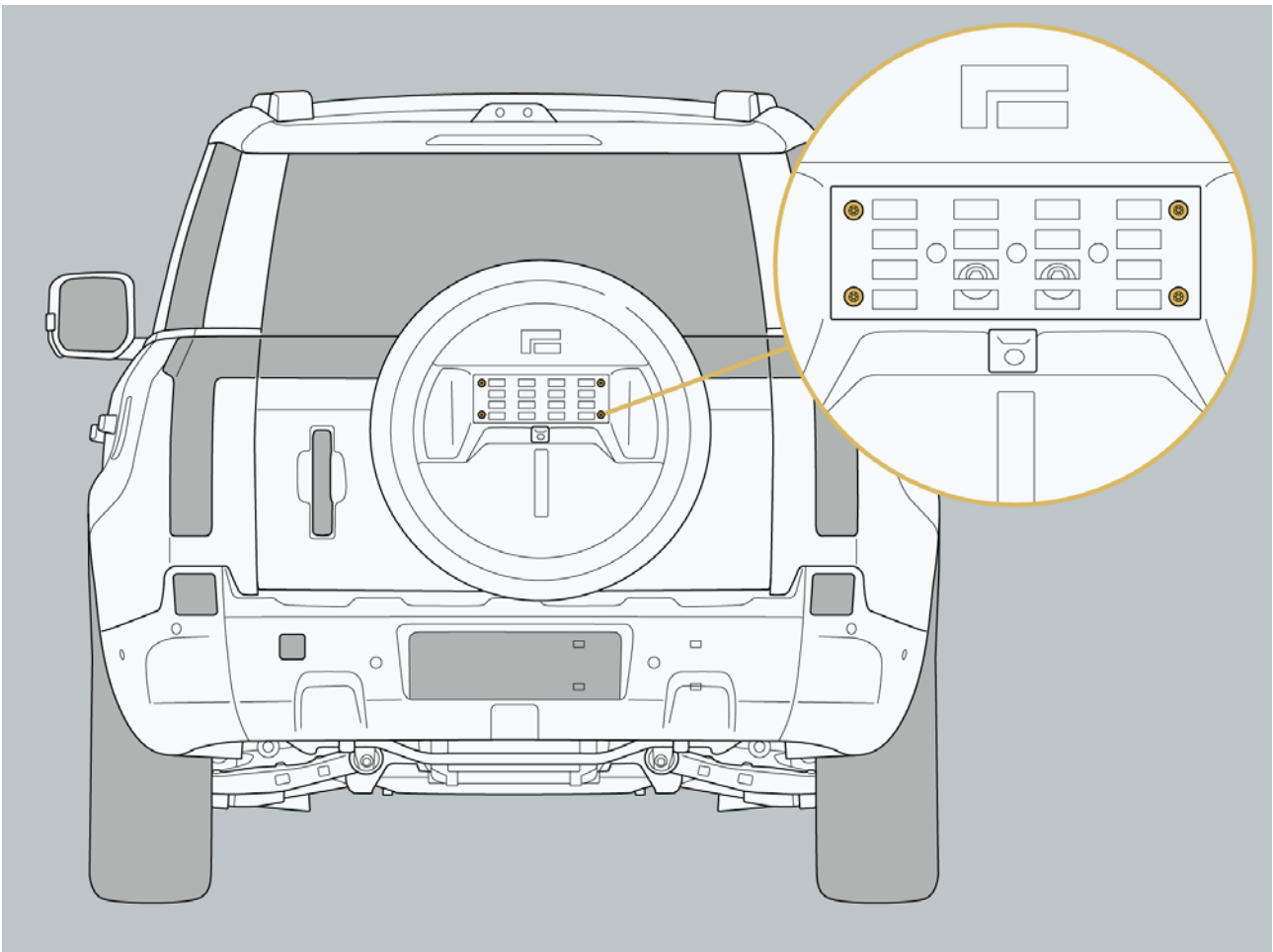

9 In case of fault

5. After taking out the spare tire housing, remove the spare tire fixing bolt counterclockwise to remove the spare tire.

Hint

- When removing the spare tire, avoid it from scratching the rear camera.

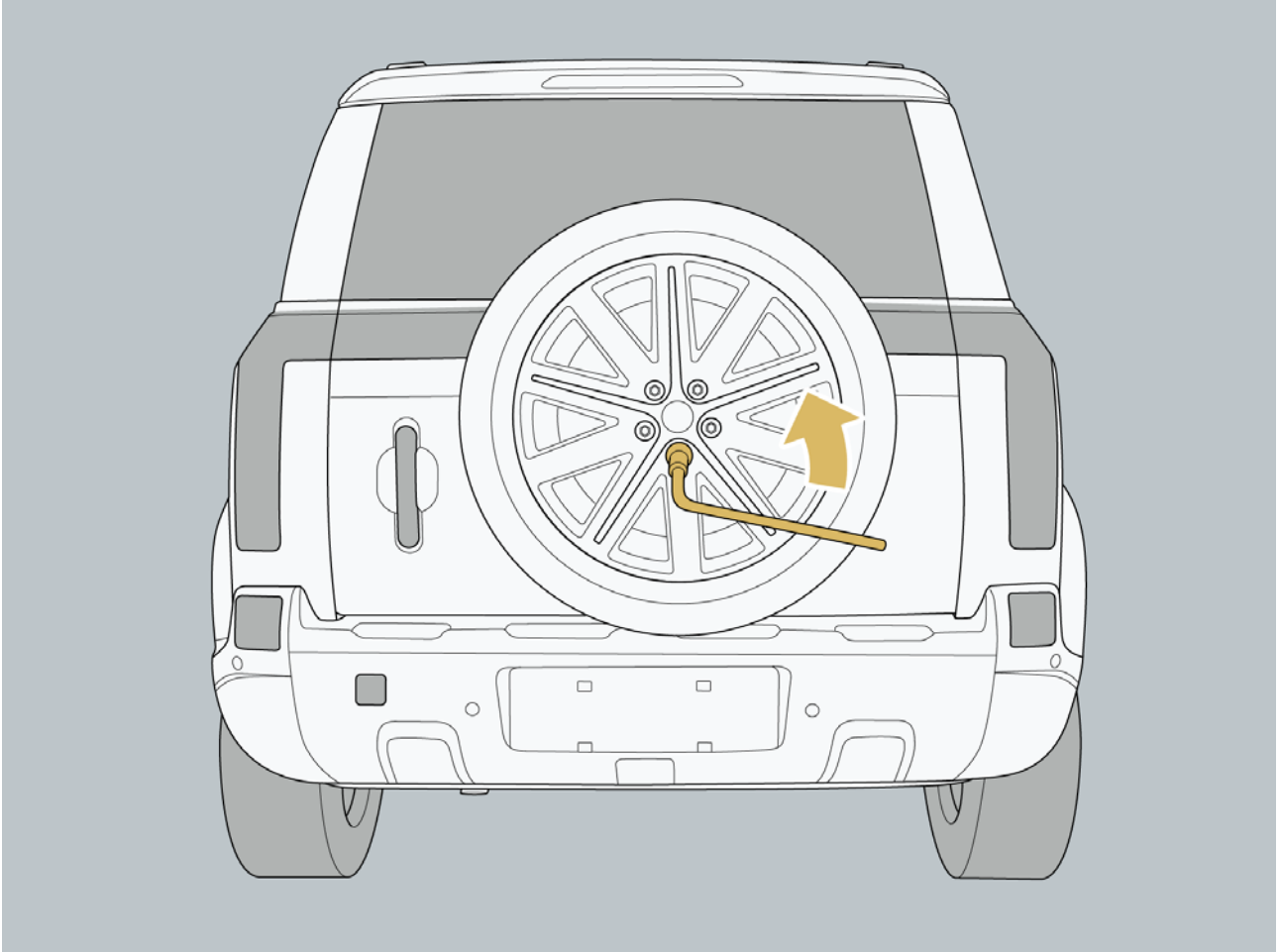

9 In case of fault

6. After removing the spare tire, place stoppers in front and behind the tire on the diagonal from the flat tire to prevent the vehicle from sliding.
7. Loosen the wheel bolts by turning them counterclockwise with the wheel wrench.

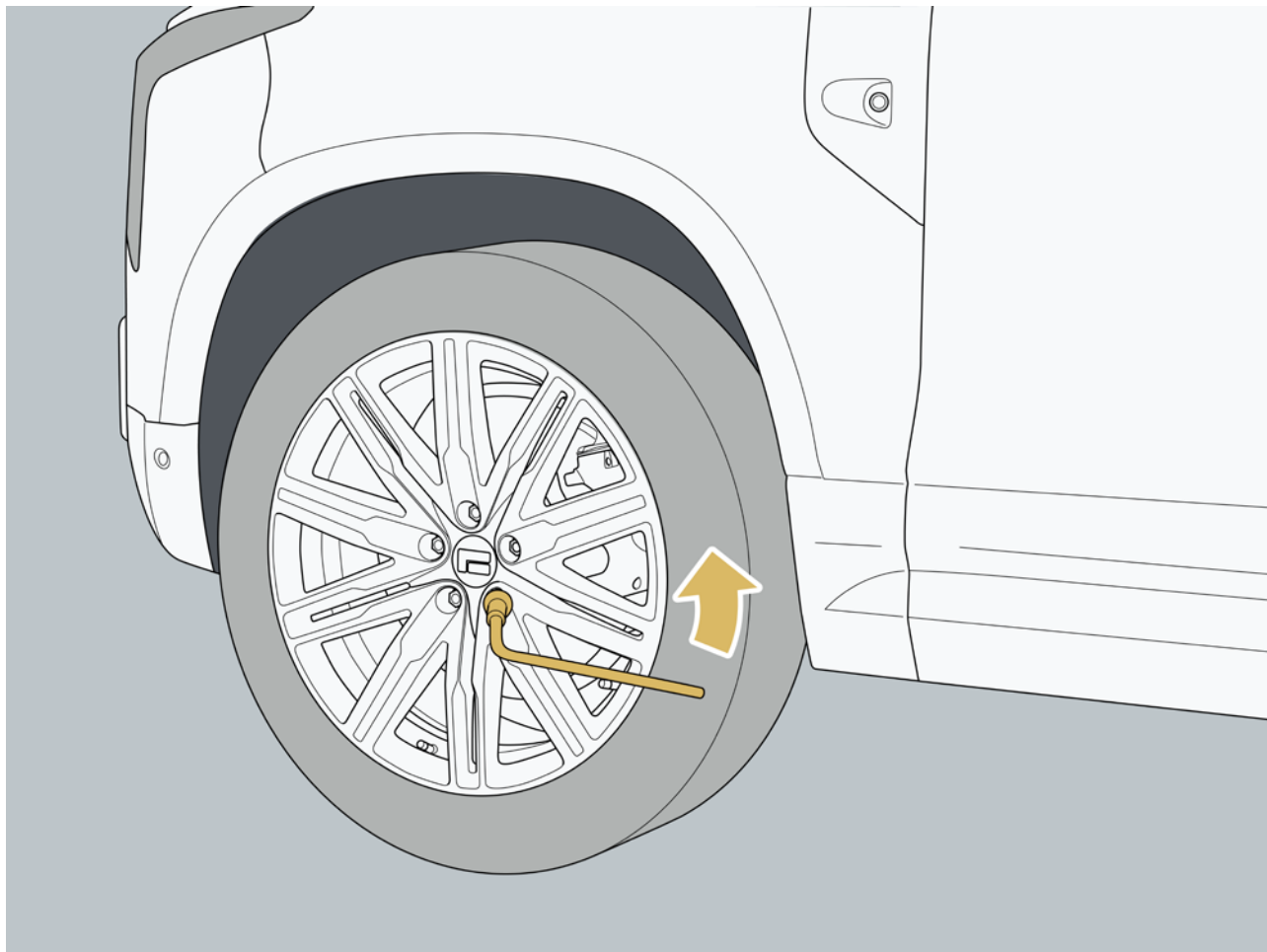

9 In case of fault

8. Place the jack at the lifting point (refer to the operation mode of the jack mark), and lift the vehicle to the height where the tire can be changed. When the jack is about to lift the vehicle, check again that the jack's position is at the correct lifting point.
 - a. Turn the tire jack "A" position by hand until the top boss of the jack completely enters the pit of the vehicle support block.
 - b. Raise the vehicle so that the tire is slightly off the ground.

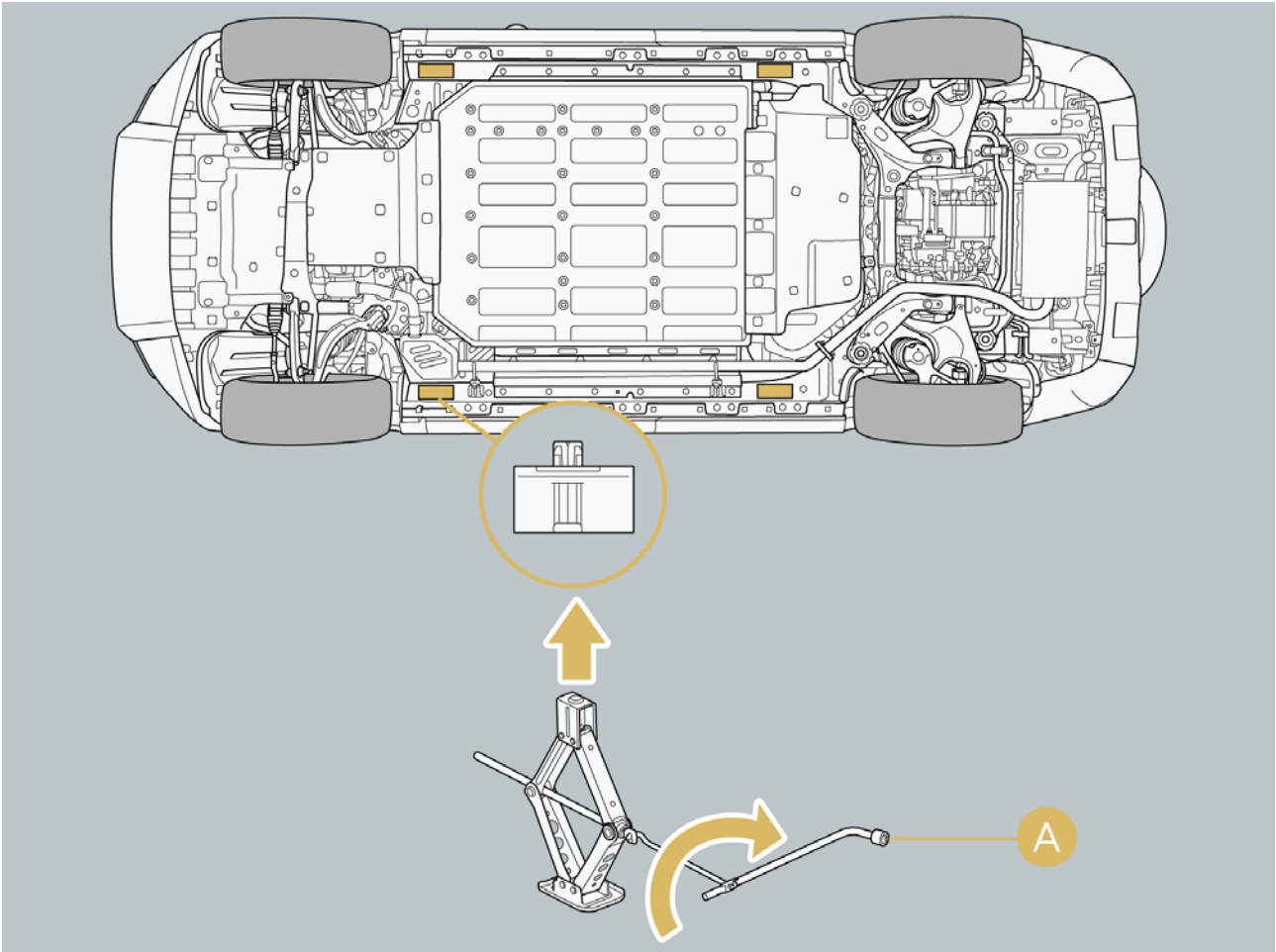

9 In case of fault

9. After removing the spare tire, place stoppers in front and behind the tire on the diagonal from the flat tire to prevent the vehicle from sliding.
10. Loosen the wheel bolts by turning them counterclockwise with the wheel wrench.

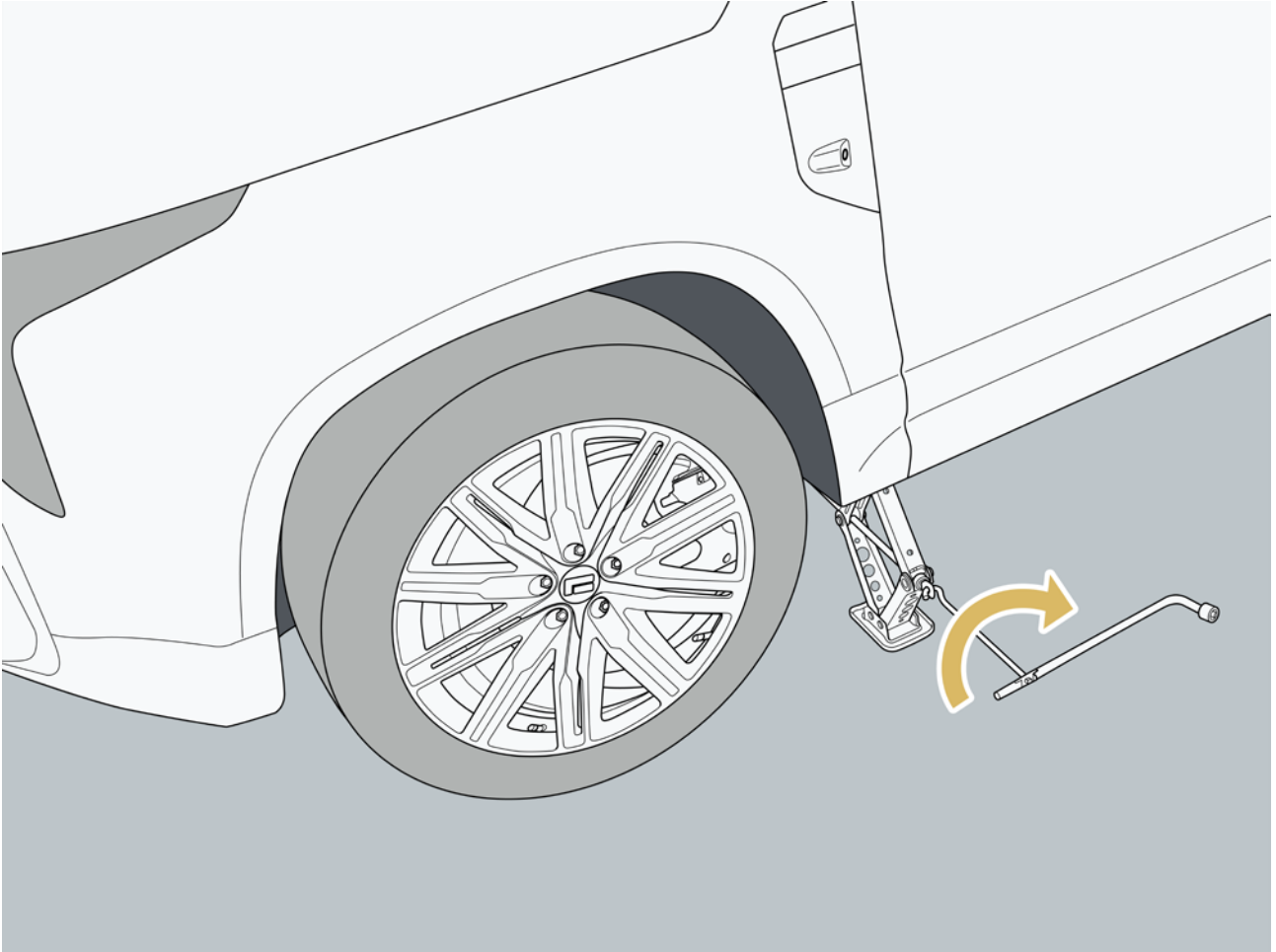

Caution

When using a jack, always observe the following. Otherwise, it is easy to damage the vehicle or cause the jack to shift, resulting in serious personal injury:

- Be sure to turn off the range extender.
- Do not use the jack when the vehicle is carrying passengers.
- The jack must be placed on a flat, hard surface.
- Do not place items on the top or bottom of the jack.
- The lifting height of the jack should not be too high. It should be suitable for changing the tire.
- When using the jack, ensure that the jack adjusting rod is coaxial with the jack lead screw rotation center. When operating, slightly jack the vehicle and carefully check for any abnormalities before continuing to slowly lift the vehicle.

11. Remove the wheel bolts and replace the tire. When installing the tire, align the bolts with the mounting holes and ensure the tire metal surface contacts the mounting surface normally.

9 In case of fault

Caution

- When placing the tire directly on the ground, place the spoke rim face up to avoid damage.
- Before installing the spare tire, it is best to place the removed tire under the vehicle to prevent the jack from shifting, causing an accident.

12. After installing the wheel bolts and lightly tightening them, lower the vehicle and remove the jack. Tighten all wheel bolts in a diagonal crisscross order with the wheel wrench, then tighten the wheel bolts to 160 Nm with the torque wrench.
13. After tightening the wheel bolts, click "Vehicle Settings → Vehicle → Mode" on the central control screen to turn off the suspension maintenance mode.
14. Check the tire pressure of the replaced tire and inflate it appropriately if necessary.

Warning

- Replacing a spare tire involves professional tools and operational skills, which has potential safety hazards. To ensure your safety, it is recommended that the operation be carried out by professionals. For assistance, please contact ROX Service Center.
- When using a jack, do not place it on the wrong support point to avoid damaging the vehicle.
- When the jack is lowering the vehicle, be aware of your surroundings to avoid pinching the operator or other people around.

Caution

- Non-spare tire models are not equipped with a spare tire. If a tire needs to be replaced, use a tire of the same specification and tread pattern.

9.1.8 Emergency start-up

I. Vehicle can drive normally but range extender cannot start

Possible causes:

- There may not be enough fuel in the fuel tank, and the instrument panel displays a low fuel warning icon.
- If the range extender system fails, the instrument panel displays a power system fault warning icon.

II. Vehicle cannot start normally and range extender cannot start

Possible causes:

- The remote key battery may be low and unable to work.
- The battery may be depleted.
- Vehicle electrical fault.

Hint

- If the above faults occur, please contact the ROX Service Center and park the vehicle in a safe area.

9 In case of fault

III. Emergency start-up powertrain

When the remote key battery level is too low, you can start the powertrain by following steps:

1. Open the door with the mechanical key.
2. Place the remote key flat at the bottom of the cup holder at the back of the center console in the direction shown in the illustration.

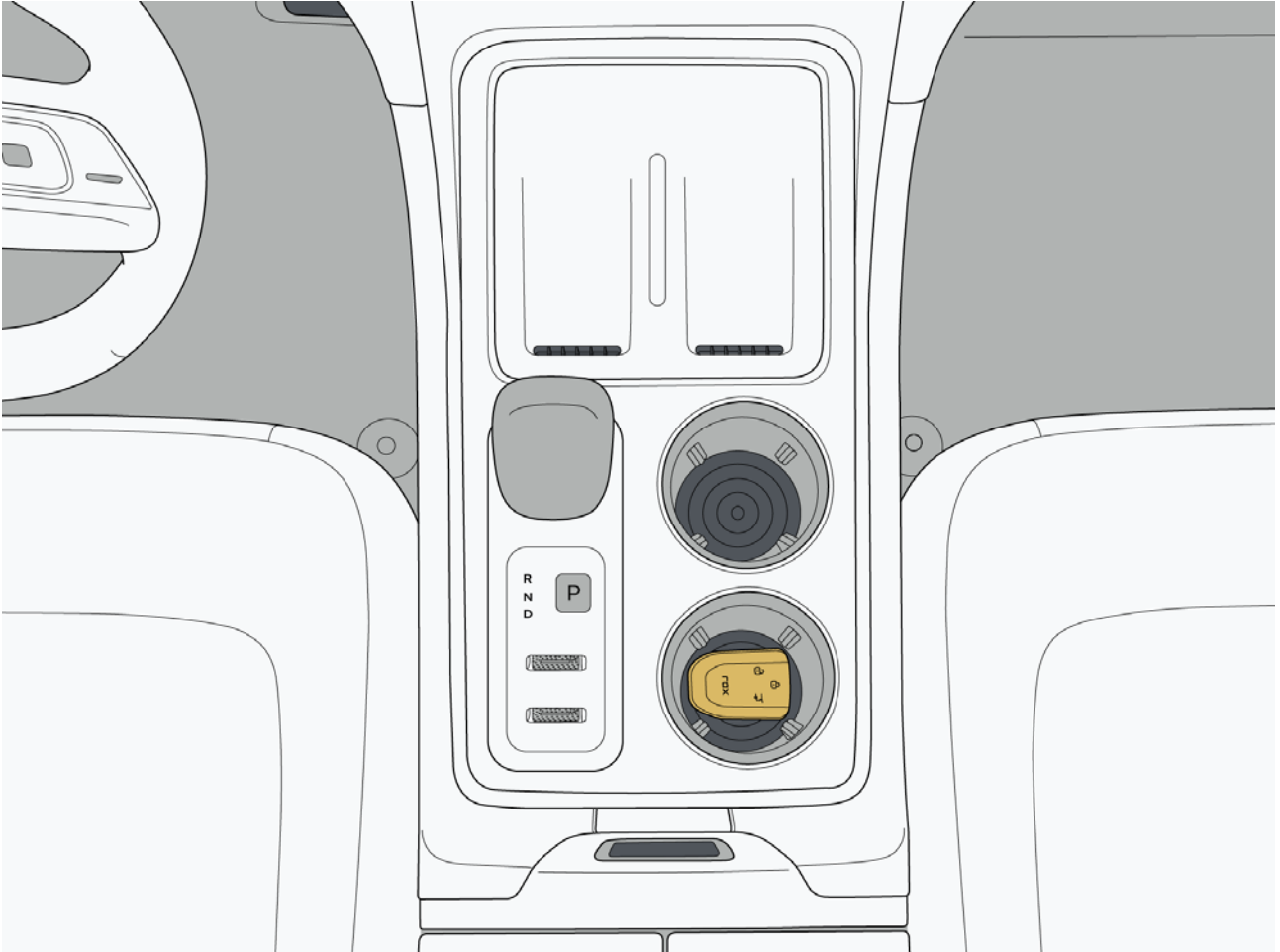

3. Check and confirm that the vehicle is in P gear.
4. Depress the brake pedal, and the READY indicator turns on.

Warning

- Do not start the range extender when the remaining fuel is extremely low. Otherwise, the emission control system and power system may be damaged due to fuel depletion. Emergency start is only a temporary measure. Whether the vehicle is started or not, please contact ROX Service Center as soon as possible.

9.1.9 Battery level depleted

If the battery fails or the interior lighting cannot be turned off due to a fault, resulting in the battery being depleted and unable to start the vehicle normally, please contact the ROX Service Center.

Caution

- Jump starting between this vehicle and another vehicle is prohibited to avoid damaging the battery.

9.1.10 Vehicle overheating

I. Vehicle overheating

1. The instrument panel displays a high temperature warning light for the range extender.
2. The power of the powertrain is reduced (e.g., unable to increase vehicle speed).
3. Steam comes out from under the hood.

II. Countermeasures

1. After parking the vehicle in a safe location, turn off the A/C system and disconnect the vehicle's power supply.
2. Turn on the hazard warning light.
3. Take the reflective vest from the trunk toolbox and wear it correctly.
4. Place the warning sign in a suitable position for the vehicle.
5. After the powertrain has cooled down sufficiently, open the hood.
6. Check if the coolant level is within the normal range. If the level is within the normal range, drive the vehicle to the ROX Service Center for inspection under safe conditions. If the level is not within the normal range, please contact the ROX Service Center immediately.

Warning

- Do not open the coolant filling cap when the coolant temperature is high, to avoid scalding.
- Do not open the hood when steam is coming out from under it, to avoid scalding.

Hint

- If the coolant level in the expansion water tank is between the "MAX" and "MIN" indicator lines, it indicates that the level is normal. If the level is not between the "MAX" and "MIN" indicator lines, it needs to be added or discharged to the normal range.

9 In case of fault

9.1.11 In case of vehicle getting stuck

I. Vehicle escape

If the tires are spinning or the vehicle is stuck in mud or snow, perform the following operations:

1. Switch the vehicle gear to P.
2. Clear the mud or snow trapped around the wheels.
3. Place wooden blocks, stones, or other items that can help increase the friction of the wheels under the stuck wheels.
4. Select an appropriate driving mode for the current road by clicking the ROX mode at the bottom of the central control screen.
5. Switch the vehicle gear to D gear, carefully depress the accelerator pedal and slightly turn the steering wheel to help the vehicle get unstuck.

Warning

- Do not use the above methods for escape in areas where the vehicle surroundings are narrow.
- Do not operate the gear shift lever when depressing the accelerator pedal, to avoid sudden acceleration causing an accident.
- If a towing bar is used for off-road rescue, ensure that the driver of the off-road vehicle and the rescue personnel have received training in off-road rescue skills.

Hint

- If the vehicle cannot be escaped after following the above steps, contact the ROX Service Center.

9.1.12 Emergency call

I. Emergency Call (E-Call)

The vehicle is equipped with an emergency call (E-Call) system. When an accident or emergency occurs, the “SOS” function can be activated manually or automatically to obtain rescue from the local road emergency rescue management center.

Warning

- Do not press the emergency call button in non-emergency situations.

II. Manual call

Press the “SOS” alarm button continuously for 3 s, or press the SOS button 5 times in quick succession within 10 s, to trigger the emergency call function. At this time the vehicle’s status information (location, time, vehicle characteristics, etc.) is automatically sent to the local road emergency rescue management center. This facilitates the rescue center to carry out rescue.

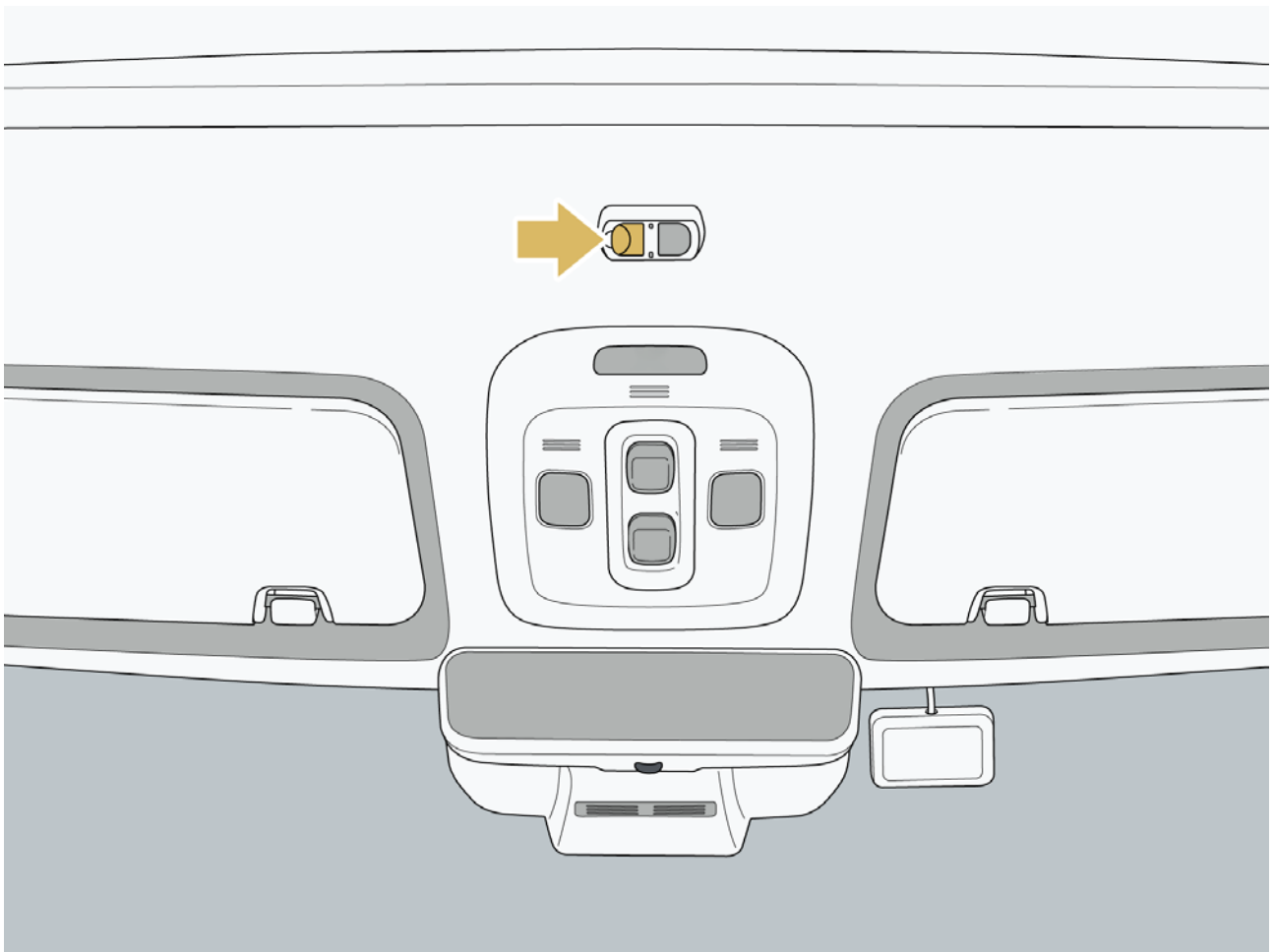

9 In case of fault

III. Cancel a manual call

After initiating a manual emergency call with a long press of 3s, the indicator will flash orange-red slowly. The slow flash will last for 6s. Within the 6s period, pressing the SOS button for more than 1s and then releasing it will cancel the manual emergency call.

Caution

- Only a manual emergency call initiated with a long press of 3 s can be canceled. Emergency calls triggered in different ways cannot be canceled.
- This function should only be used in emergency situations, such as accidents, illness or threats to occupants.

IV. Automatic call

When the vehicle sensors detect a collision, rollover, or other accidents, or when the vehicle system receives information about an accident, the alarm function will be automatically triggered. The vehicle's status information (location, time, vehicle characteristics, etc.) is automatically sent to the local road emergency rescue management center. This facilitates the rescue center to carry out rescue.

V. Indicator instruction

Working status	Instruction
Off status	Total indicator runout
Normal standby operation	"SOS" key white backlight always on
E-Call fault	Red indicator always on
Emergency call center	Green indicator flickering
Emergency call connected	Green indicator flickering
Terminating emergency call center	Red indicator flickering
Mode testing	Orange indicator flickering
Self-check	Orange and backlight flashing

9.2 Accident rescue

9.2.1 Appearance identification information

Identify this electric vehicle by its external features:

1. The "ADAMAS" logo on the right side of the tailgate panel.
2. Charging port cover.

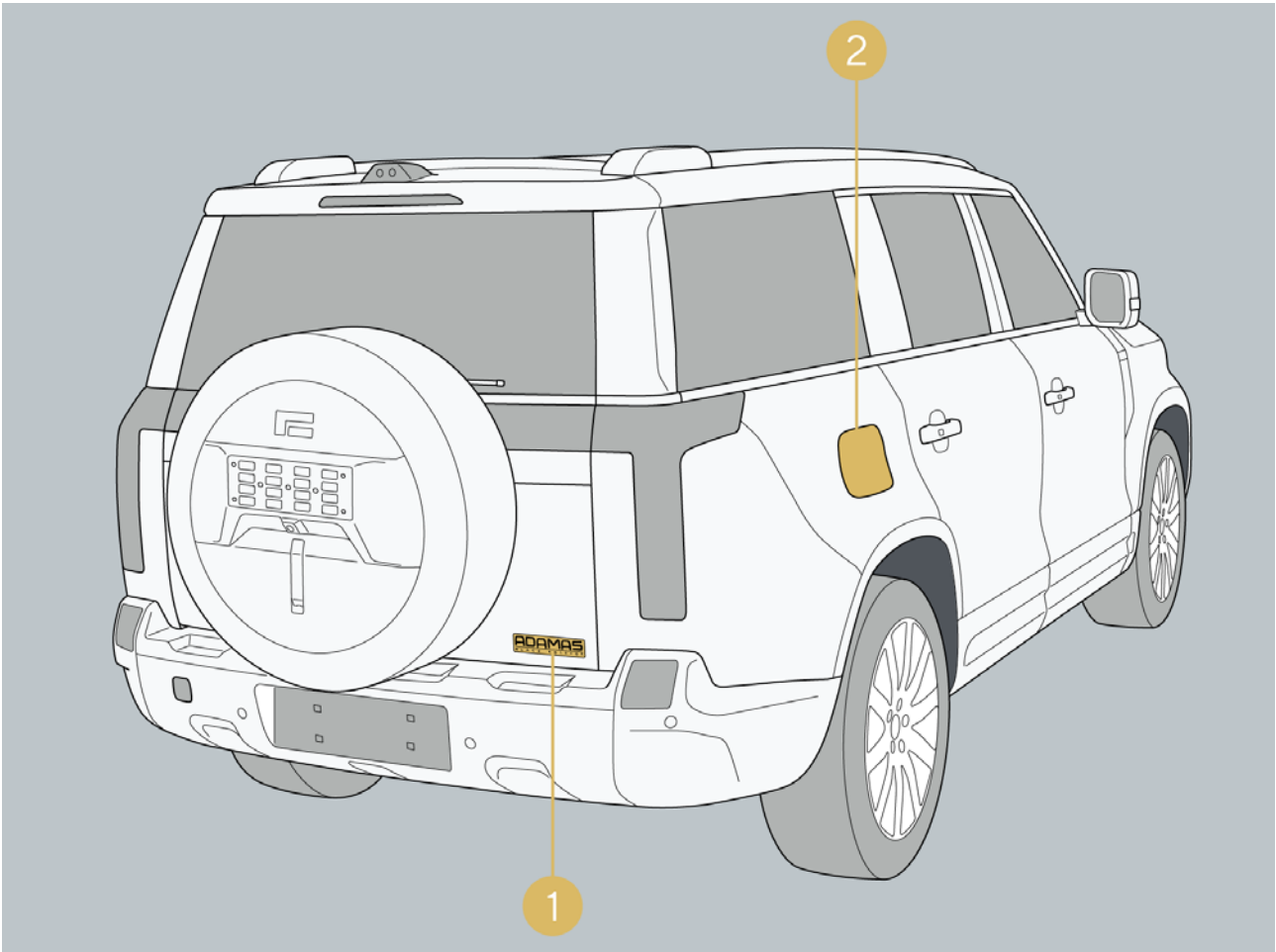

9 In case of fault

9.2.2 Rescue protection device

The powertrain of the vehicle is driven by high-voltage batteries. In the event of a serious collision, there may be a risk of electrical leakage or battery electrolyte leakage. Therefore, when performing vehicle rescue operations, professional rescuers should wear protective devices for rescue operations.

I. Physical protection

When rescuing the vehicle, please wear the following protective equipment to prevent electrical accidents:

- High-voltage insulating gloves (natural rubber insulating 1,000 V or more).
- Goggles.
- Insulated rubber shoes.
- Insulating mat (can be used as an alternative if there are no insulating rubber shoes/boots).
- Tools with insulating protective sleeve.

II. Chemical protection

If the battery leaks, please wear the following protective equipment to avoid injury to the face, skin, etc.:

- Protection mask.
- Solvent insulating gloves.

Warning

- When performing rescue operations, please take off the metal products (such as necklaces, watches, etc.) on the body to prevent electric shock.

9.2.3 Emergency cut-off high voltage system

Before performing high-voltage operations on the vehicle, such as troubleshooting, assembly, maintenance and rescue, the vehicle's high-voltage system must be powered off.

Method 1

1. Click "Vehicle Settings → Vehicle → Driving → Vehicle Power" on the central control screen and click "Power Off" to power off the vehicle.
2. Open the front hood and remove the inspection cover of the front engine compartment fuse box.

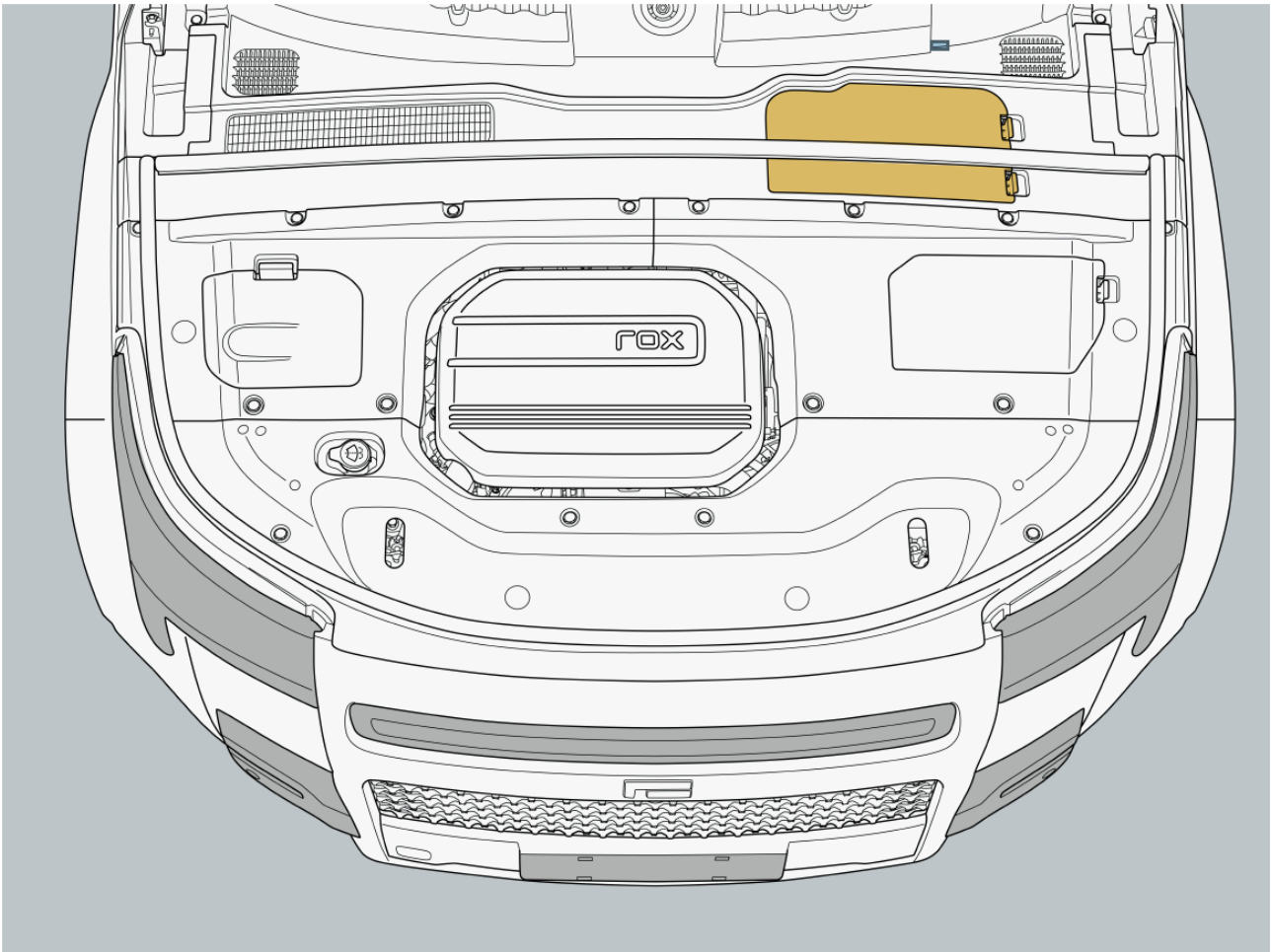

9 In case of fault

3. Disconnect the manual service switch harness connector.
4. Open the tailgate, remove the tool box cover plate, and disconnect the negative connection.

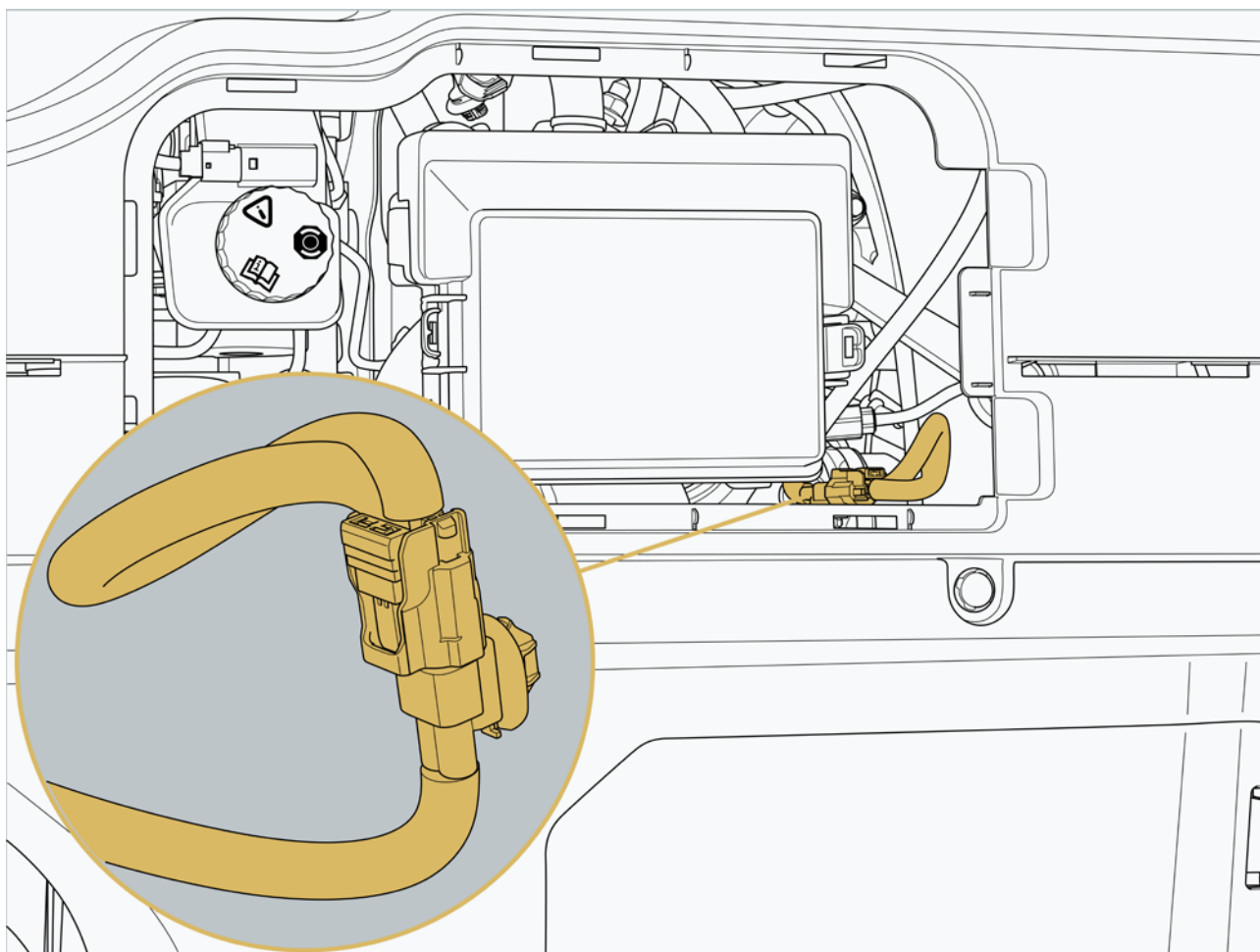

Method 2

1. Disconnect the vehicle's external high-voltage charging connection, such as the charger.
2. Turn on the vehicle's Bluetooth and connect the vehicle Bluetooth to your phone's Bluetooth.
3. Click the communication icon on the central control screen to enter the communication application.
4. Enter the communication application, input `**#800800#` in the dialing pad, and then enter the engineering mode.
5. After entering the engineering mode, click the "One-click Off" function bar on the left, and click "One-click Off" on the right to cut off the high-voltage system. Click "One-click On" to restore the high-voltage system.
6. After the vehicle's high-voltage system is powered off, disconnect the negative terminal of the battery.

Warning

- Do not perform high-voltage work such as troubleshooting, assembly, maintenance and rescue when the vehicle is not powered off, to avoid electric shock.

- The disconnection of the manual maintenance switch harness connector must be operated by professionals, and it is forbidden to operate by yourself to prevent electric shock.

9.2.4 Vehicle fire rescue

When the vehicle is on fire, take the following rescue measures:

1. If you find smoke or fire while driving, stop the vehicle immediately and have all passengers leave the vehicle.
2. If you find smoke or fire while the vehicle is stationary, evacuate the surrounding people immediately. If the vehicle is charging, press the emergency switch on the charging pile immediately to stop the vehicle from continuing to charge.
3. If the fire is not very intense, the on-site personnel should use dry powder or foam fire extinguishers to put out the fire as soon as possible to prevent the fire from expanding.
4. If the fire is intense, professionals should wear protective devices to put out the fire.

Warning

- If the vehicle is on fire, do not touch any part of the vehicle. Professionals should wear protective devices for rescue.
- The gas stored in the side curtain airbag cylinder and the high-pressure air suspension cylinder may expand due to heat in high-temperature and may explode. Please be extremely careful before performing any operation to avoid personal injury.

9.2.5 Vehicle wading rescue

It is recommended not to drive the vehicle in deep water for a long time to avoid damage to the vehicle's high-voltage system.

Under the premise that the vehicle body and chassis are not damaged, there will be no greater risk of electric shock due to immersion in water. However, professional rescue personnel need to wear appropriate rescue protective equipment. First pull the vehicle out of the water, and then cut off the high-voltage system immediately.

Warning

- Do not touch the submerged vehicle without wearing protective equipment to avoid electric shock.

9 In case of fault

9.2.6 Battery leak rescue

When a high-voltage battery leaks, it may generate high temperatures or even cause a fire. Cool down the high-voltage battery before handling the leaked liquid.

Warning

- When the battery electrolyte leaks, it should be handled by professional rescue personnel wearing protective masks and solvent-resistant gloves. Do not touch the liquid directly.
- When the battery electrolyte leaks, avoid contact with the electrolyte on the skin and eyes. In case of contact, rinse with a large amount of water for 15 min and seek medical assistance. Any person or animal is prohibited from swallowing any part of the battery and any substance contained in the battery.











9.2.7 Vehicle cutting area

When the vehicle needs to be cut, it should be performed by professionals with appropriate tools.

The high-voltage power, airbag and flammable areas of the vehicle are prohibited cutting areas, as shown in the figure below.

Warning

- Do not cut vehicle parts randomly. If the vehicle needs to be cut, it should be done by professionals to prevent serious personal injury.

Icon	Name	Icon	Name
	High voltage part		Air-spring air storage cylinder
	Airbag		Fuel tank
	Stiffener		Airbag controller
	Seat belt pretensioner		Side air curtain cylinder
	Low voltage battery		Air spring
	Air spring		

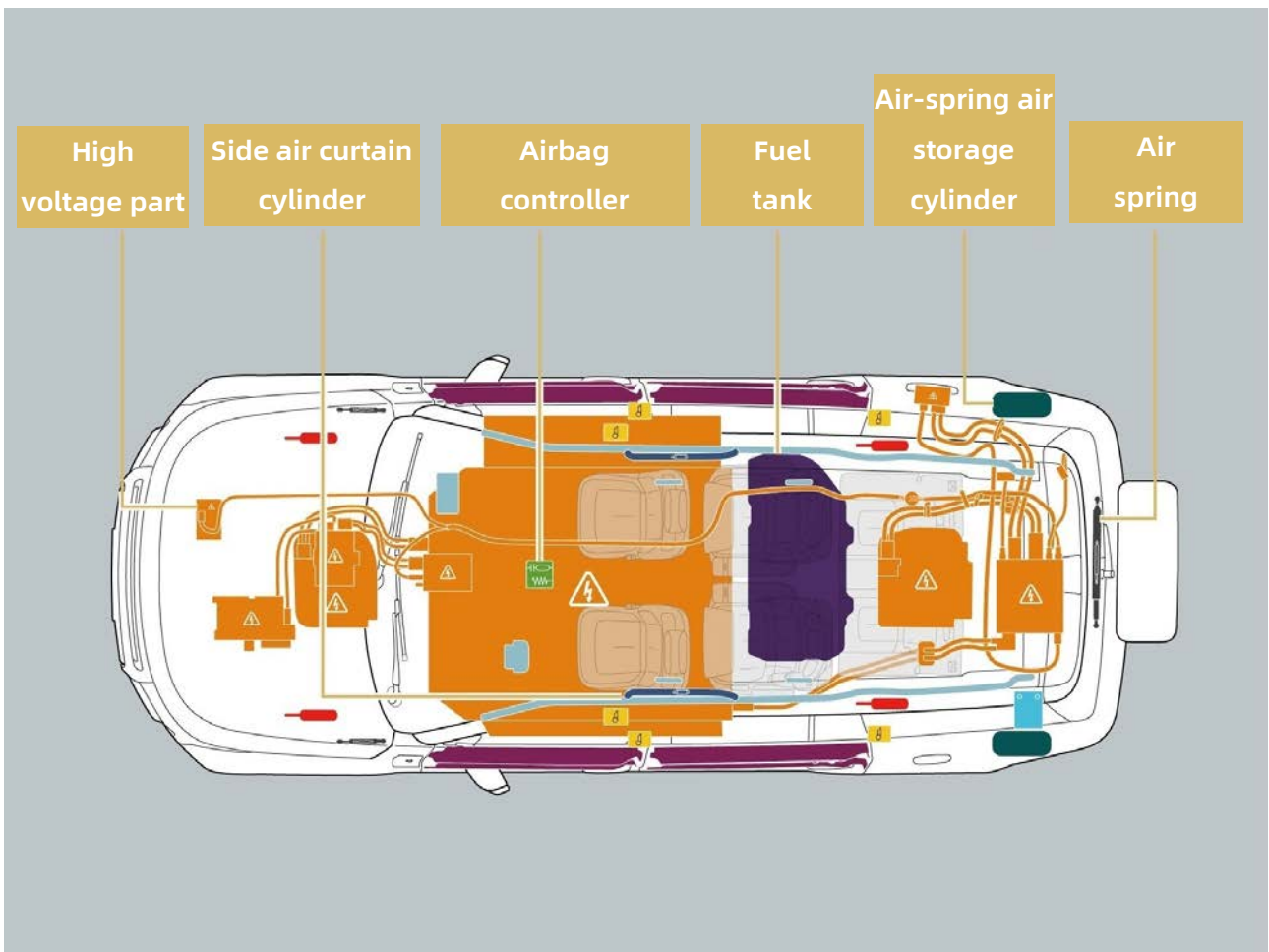

9 In case of fault

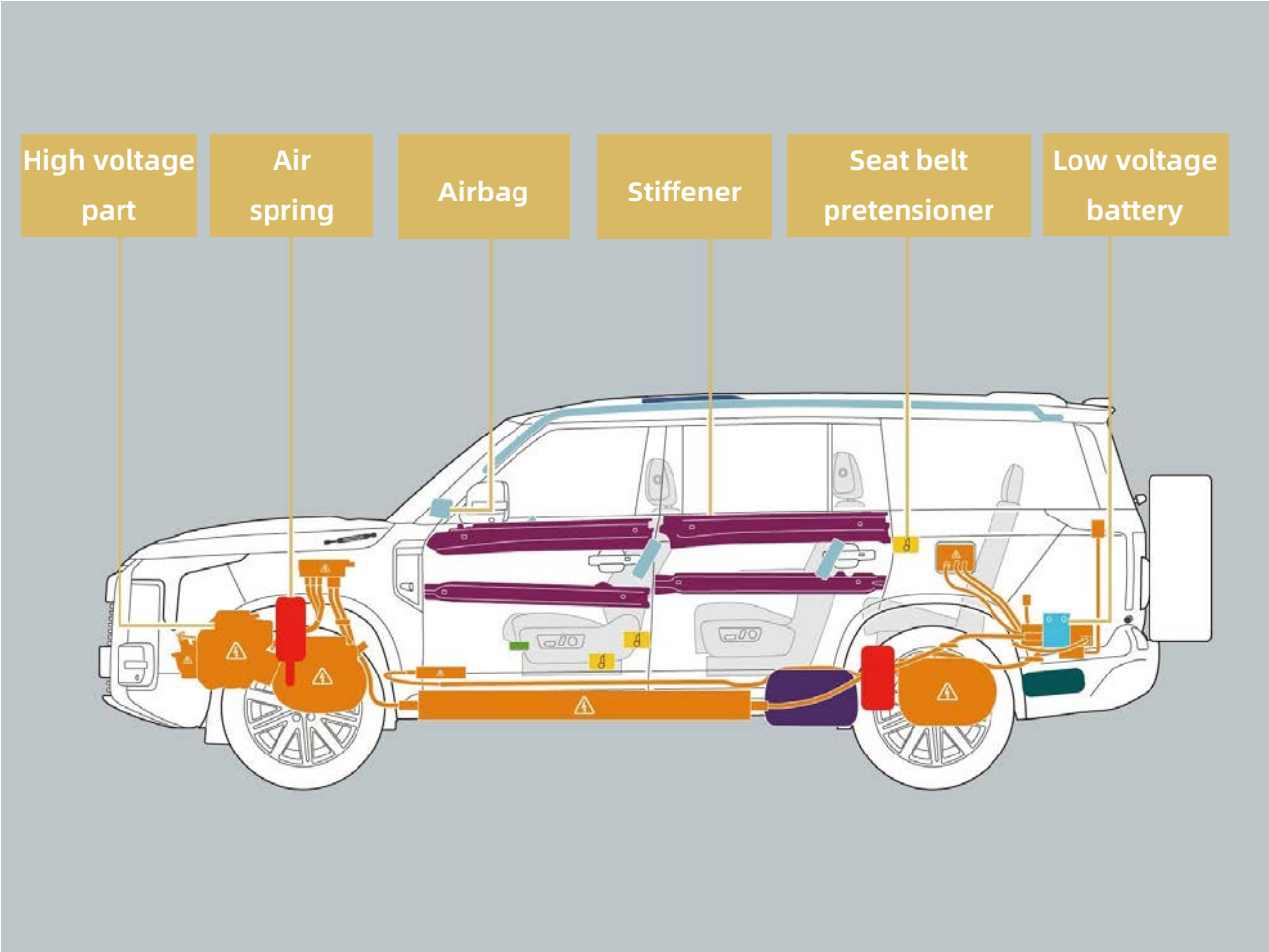

9.3 Vehicle remote diagnosis

9.3.1 Vehicle remote diagnosis system

This vehicle has a remote diagnostic function. With your consent, we can provide remote diagnostic services by remotely using information such as VIN, electronic control unit diagnostic data and diagnostic process vehicle data to help analyze and solve related faults or problems.

Hint

- Due to differences in vehicle configuration, software service version or market region, the vehicle may not be equipped with this function, or the performance of the function may differ from the description in this manual. Please refer to the actual function equipped on the vehicle for details.

10 Vehicle specification

10.1 Specification

10.1.1 Maintenance data (fuel, oil, etc.)

I. Fuel

Item	Parameter
Fuel type	Unleaded gasoline only
Octane value	RON95 # and above
Fuel tank capacity	70L

Warning

- Do not use substandard fuel to avoid damaging the range extender. If you accidentally add fuel that does not meet the standards, please do not start the vehicle and contact ROX Service Center immediately.

II. Engine oil

Item	Parameter
Engine oil type	0W-20 SM grade or higher

III. Refrigerant

Item	Parameter
Refrigerant type	R134a
Filling volume	1100g±25g

IV. Brake fluid

Item	Parameter
Brake fluid type	DOT4
Filling volume	Fill to close to the MAX line (approx. 0.85 L)

10.2 Main dimension parameters of vehicle

10.2.1 Front and back of vehicle

I. Front and back of vehicle

1. Model with a spare tire

S/N	Item	Parameter
1	Vehicle height (air spring)	1856mm
1	Vehicle height (spiral spring)	1869mm
2	Front tread	1692mm
3	Vehicle width	1985mm
4	Rear track	1701mm
5	Minimum ground clearance (air spring)	190mm
5	Minimum ground clearance (spiral spring)	204mm

Note: The external rearview mirrors (one left and one right) are not included in the vehicle's width dimensions.

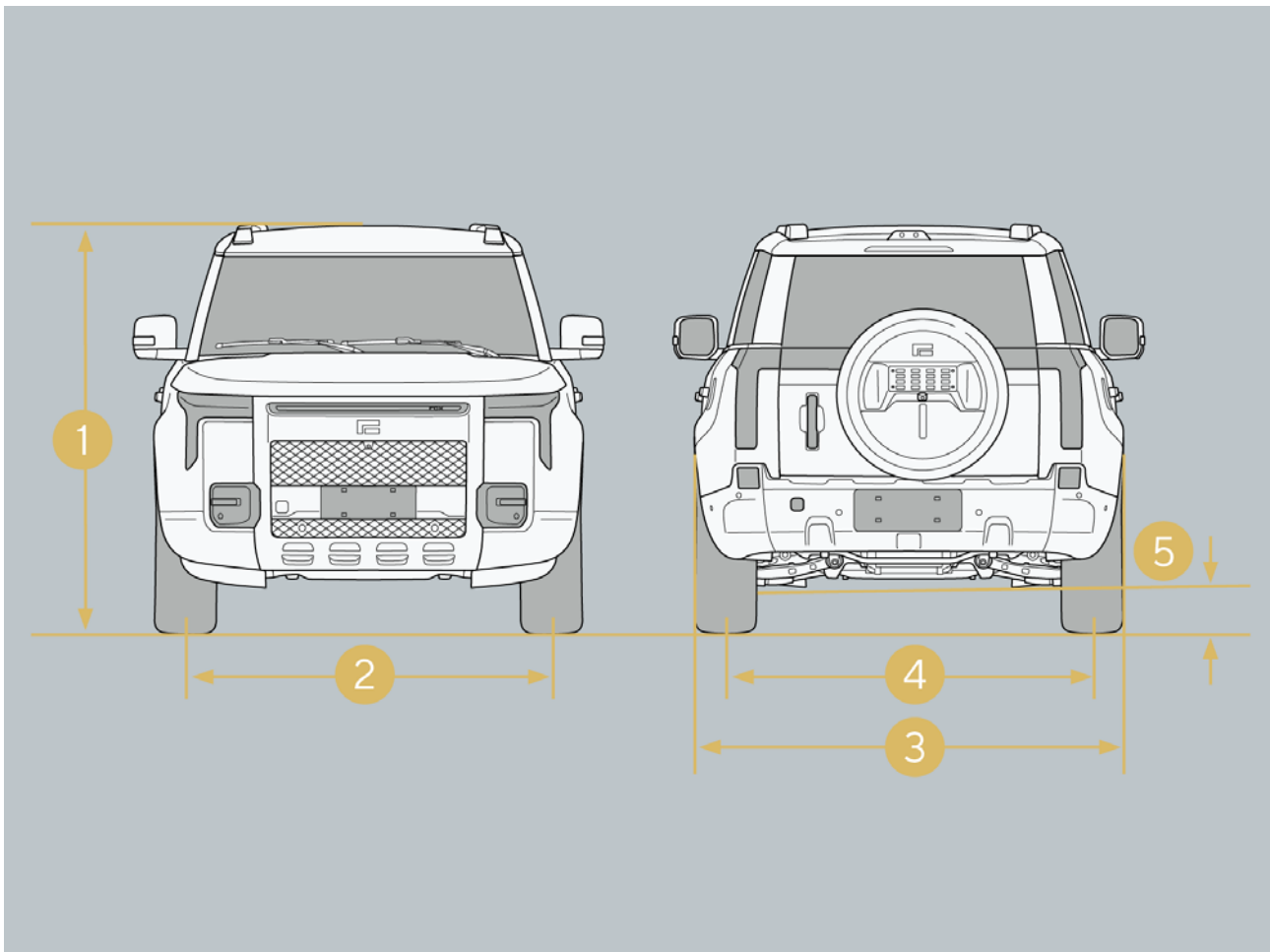

10 Vehicle specification

2. Model without a spare tire

S/N	Item	Parameter
1	Vehicle height (air spring)	1856mm
1	Vehicle height (spiral spring)	1869mm
2	Front tread	1692mm
3	Vehicle width	1985mm
4	Rear track	1701mm
5	Minimum ground clearance (air spring)	190mm
5	Minimum ground clearance (spiral spring)	204mm

Note: The external rearview mirrors (one left and one right) are not included in the vehicle's width dimensions.

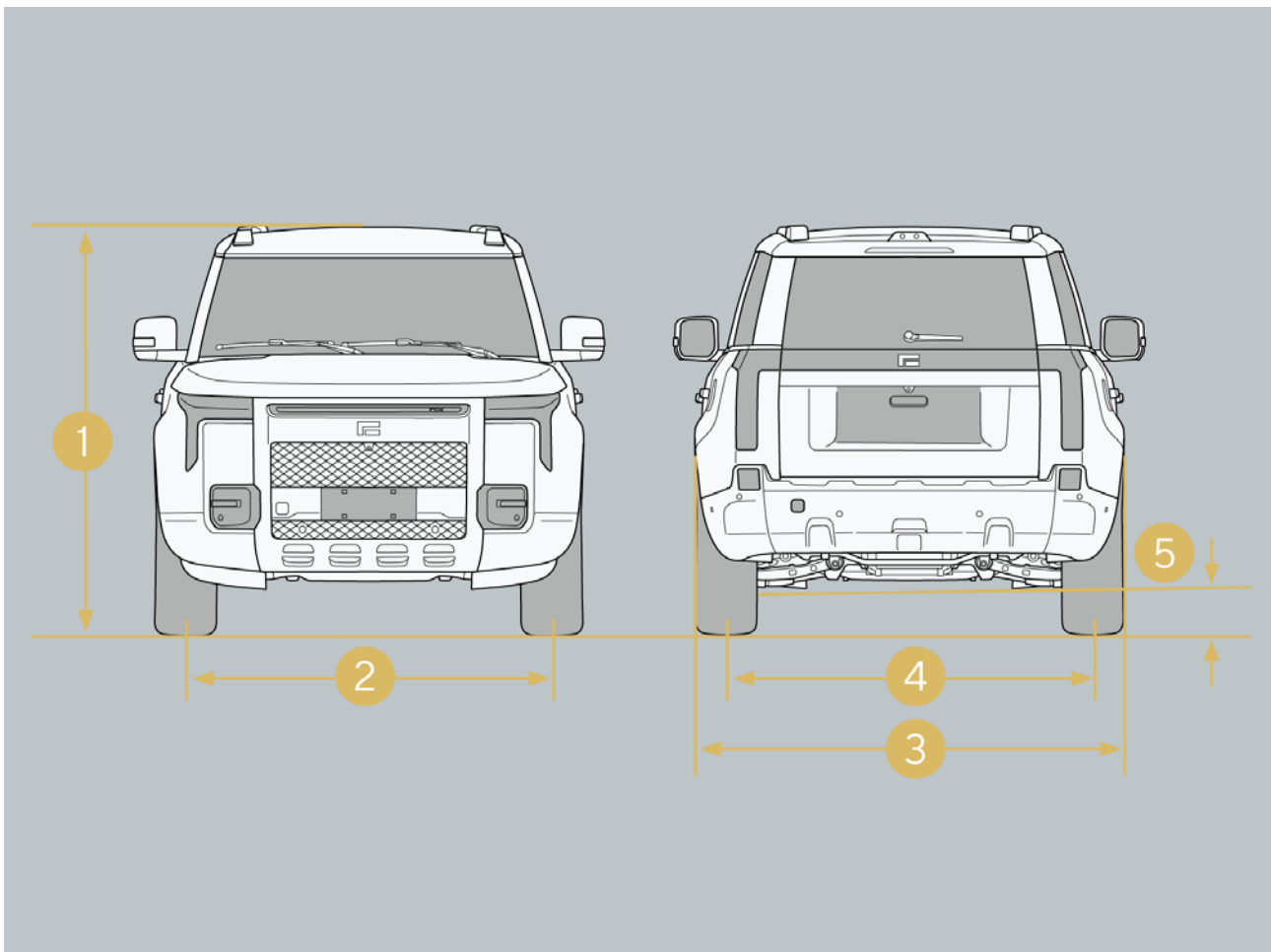

10.2.2 Vehicle side

I. Model with a spare tire

1. Model with a spare tire

S/N	Item	Parameter
1	Vehicle length	5298mm
2	Wheelbase	3010mm
3	Front overhang	965mm
4	Rear overhang	1323mm
5	Approach angle (air Spring)	$\geq 21.3^\circ$
5	Approach angle (spiral spring)	22°
6	Departure angle (air spring)	$\geq 23.6^\circ$
6	Departure angle (spiral spring)	25°

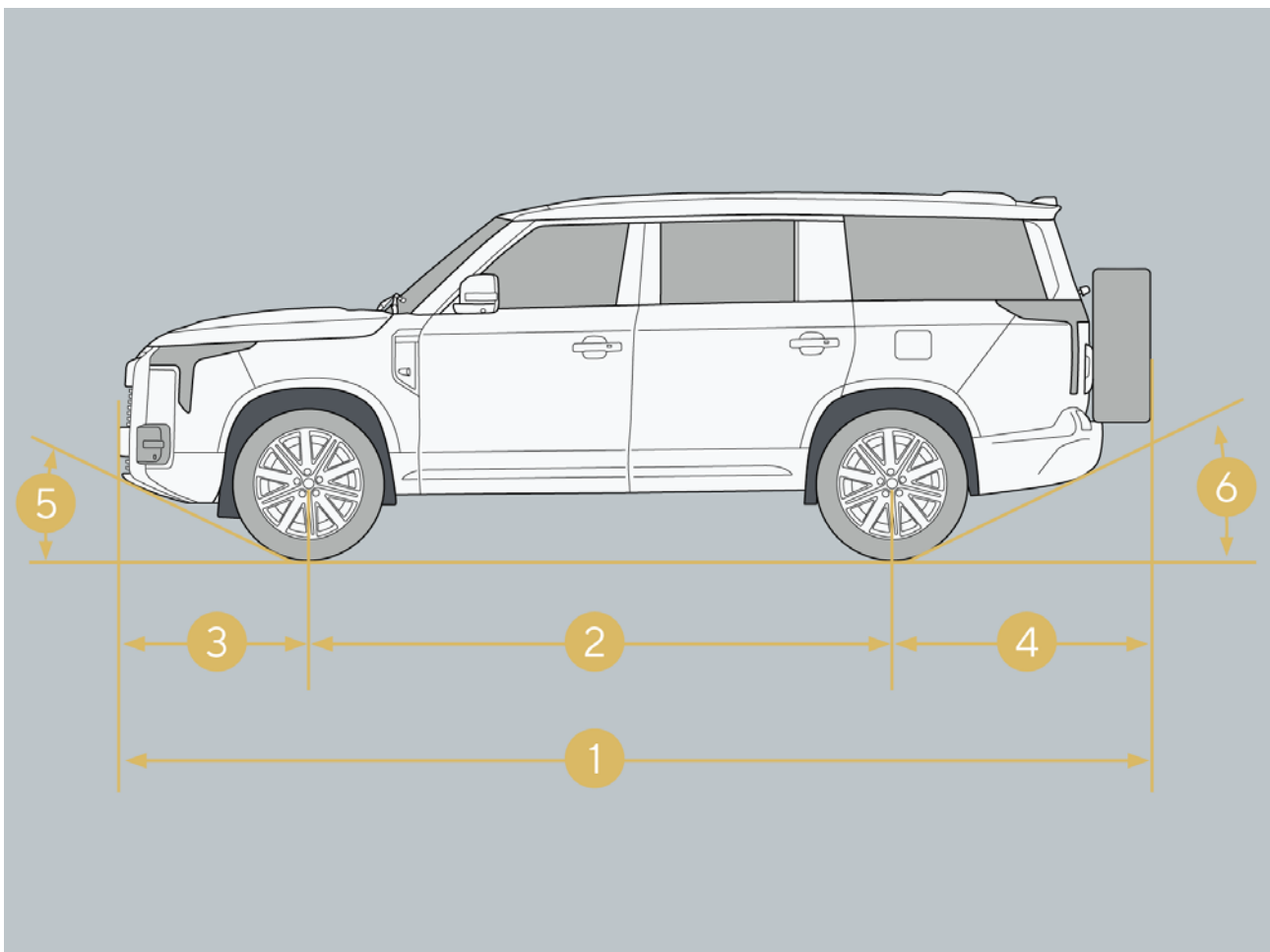

10 Vehicle specification

2. Model without a spare tire

S/N	Item	Parameter
1	Vehicle length	5050mm
2	Wheelbase	3010mm
3	Front overhang	965mm
4	Rear overhang	1075mm
5	Approach angle (air Spring)	$\geq 21.3^\circ$
5	Approach angle (spiral spring)	22°
6	Departure angle (air spring)	$\geq 23.6^\circ$
6	Departure angle (spiral spring)	25°

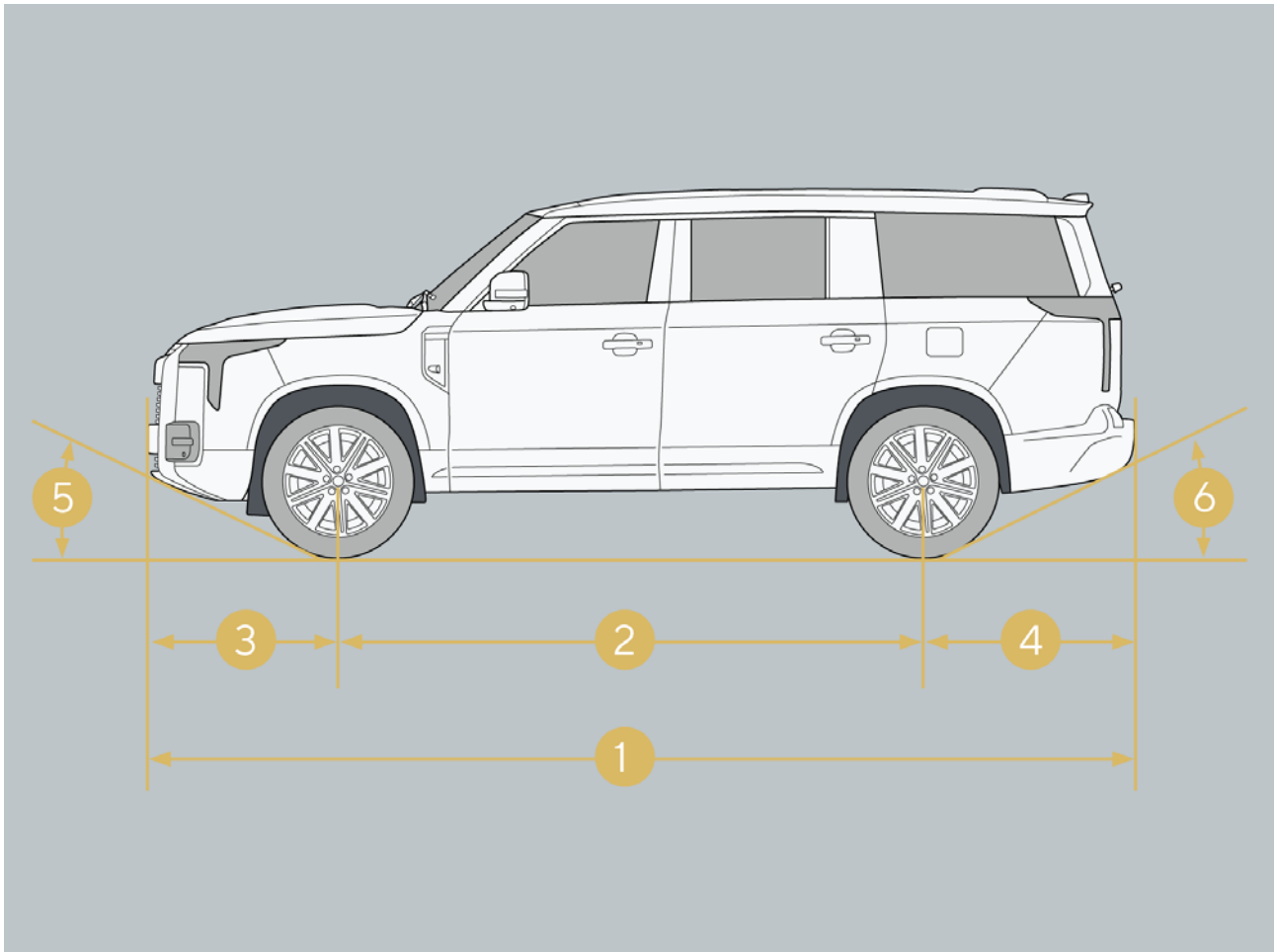

Note: The above dimensions are the measured values at curb weight.

10.3 Vehicle technical performance parameters

10.3.1 Vehicle mass parameters

Item	Parameter
Curb mass	2745 kg
Front axle load at curb weight	1325 kg
Rear axle load at curb weight	1420 kg
Max. allowable front axle load	1420 kg
Max. allowable rear axle load	1880 kg
Max. allowable gross weight	3300 kg

10.3.2 Power parameter

Item	Parameter
Max. speed	190km/h
Maximum gradeability	45°

10.3.3 Energy economy parameter

Item	Parameter
Fuel consumption	Refer to Vehicle energy consumption label
Power consumption	Refer to Vehicle energy consumption label
Electric energy equivalent fuel consumption	Refer to Vehicle energy consumption label
Fuel consumption in minimum charge state	Refer to Vehicle energy consumption label

10.3.4 Vehicle model

Item	Parameter
Vehicle model	BAW*****

Hint

- Each * represents a number or a letter, please refer to the real car.

10 Vehicle specification

10.3.5 Drive type

Item	Parameter
Drive type	Front and rear dual motor four-wheel drive

10.4 Assembly technical parameters

10.4.1 Range extender (engine) specifications and parameter

Item	Parameter
Model	4A95TD
Number of cylinders	4-cylinder
Bore x stroke	73mmx89.5mm
Displacement	1.498L
Compression ratio	14: 1
Max. net power/speed	108kW/4800rpm
Max. net torque/speed	220 Nm/2400~4,400 rpm

10.4.2 Tire and hub parameters

Item	Parameter	
	Model with a spare tire	Model without a spare tire
Tire specification	275/45R21 110Y	275/45R21 110Y
	265/50R20 111T	265/50R20 111T
Wheel hub specifications	R21X9.0J	R21X9.0J
	R20X8.5J	R20X8.5J
Wheel hub bolt torque	160±16Nm	160±16Nm
Vehicle dynamic balancing requirements	Residual dynamic unbalance within 5g on one side	Residual dynamic unbalance within 5g on one side

Hint

- The tire pressure label is located on the rim of the driver's door, and the tire pressure shown on the label is the cold tire pressure value.

10 Vehicle specification

10.4.3 Four-wheel alignment

I. Front wheel (air spring)

Parameter name	Parameter value
Front wheel single-side toe-in	$0.167^{\circ} \pm 0.1^{\circ}$
Front wheel total toe-in	$0.333^{\circ} \pm 0.2^{\circ}$
Front wheel camber	$-0.583^{\circ} \pm 0.5^{\circ}$
Front wheel camber difference	0.5°

II . Front wheel (spiral spring)

Parameter name	Parameter value
Front wheel single-side toe-in	$0.2^{\circ} \pm 0.1^{\circ}$
Front wheel total toe-in	$0.4^{\circ} \pm 0.2^{\circ}$
Front wheel camber	$-0.4^{\circ} \pm 0.5^{\circ}$
Front wheel camber difference	0.5°

III. Rear wheel (air spring)

Parameter name	Parameter value
Single-side toe-in	$0.117^{\circ} \pm 0.1^{\circ}$
Total toe-in	$0.233^{\circ} \pm 0.2^{\circ}$
Camber	$1.6^{\circ} \pm 0.5^{\circ}$
Camber difference	0.5°

IV. Rear wheel (spiral spring)

Parameter name	Parameter value
Single-side toe-in	$0.1^{\circ} \pm 0.1^{\circ}$
Total toe-in	$0.2^{\circ} \pm 0.2^{\circ}$
Camber	$-1.2^{\circ} \pm 0.5^{\circ}$
Camber difference	0.5°

10.4.4 Drive motor performance parameters

I. Front drive motor performance parameters

Item	Parameter
Rated power	66kW
Rated speed	4800rpm
Rated torque	131Nm
Peak power	150kW
Peak speed	16000rpm
Peak torque	340Nm

II. Rear drive motor performance parameters

Item	Parameter
Rated power	80kW
Rated speed	4365rpm
Rated torque	175Nm
Peak power	200kW
Peak speed	16000rpm
Peak torque	400Nm

10.4.5 Power battery parameter

Item	Parameter
Battery type	Ternary lithium-ion battery
Battery rated voltage	352.3V
Battery rated capacity	159Ah
Battery rated energy	56.01kWh

10 Vehicle specification

10.4.6 Brake system parameters

Brake system parameters	
Item	Parameter
Standard thickness of front brake disc	32mm
Min. thickness of front brake disc	29mm
Standard thickness of front brake pad	8.5mm
Min. thickness of front brake pad	2mm
Standard thickness of rear brake disc	24mm
Min. thickness of rear brake disc	21mm
Standard thickness of rear brake pad	8mm
Min. thickness of rear brake pad	2mm
Brake pedal free travel	7~10mm

10.5 Vehicle identification information

10.5.1 Vehicle identification number (VIN)

Vehicle identification number (VIN)

The VIN is the legal identification number of the vehicle, which is unique and is engraved at the following locations:

- Left front of the dashboard.

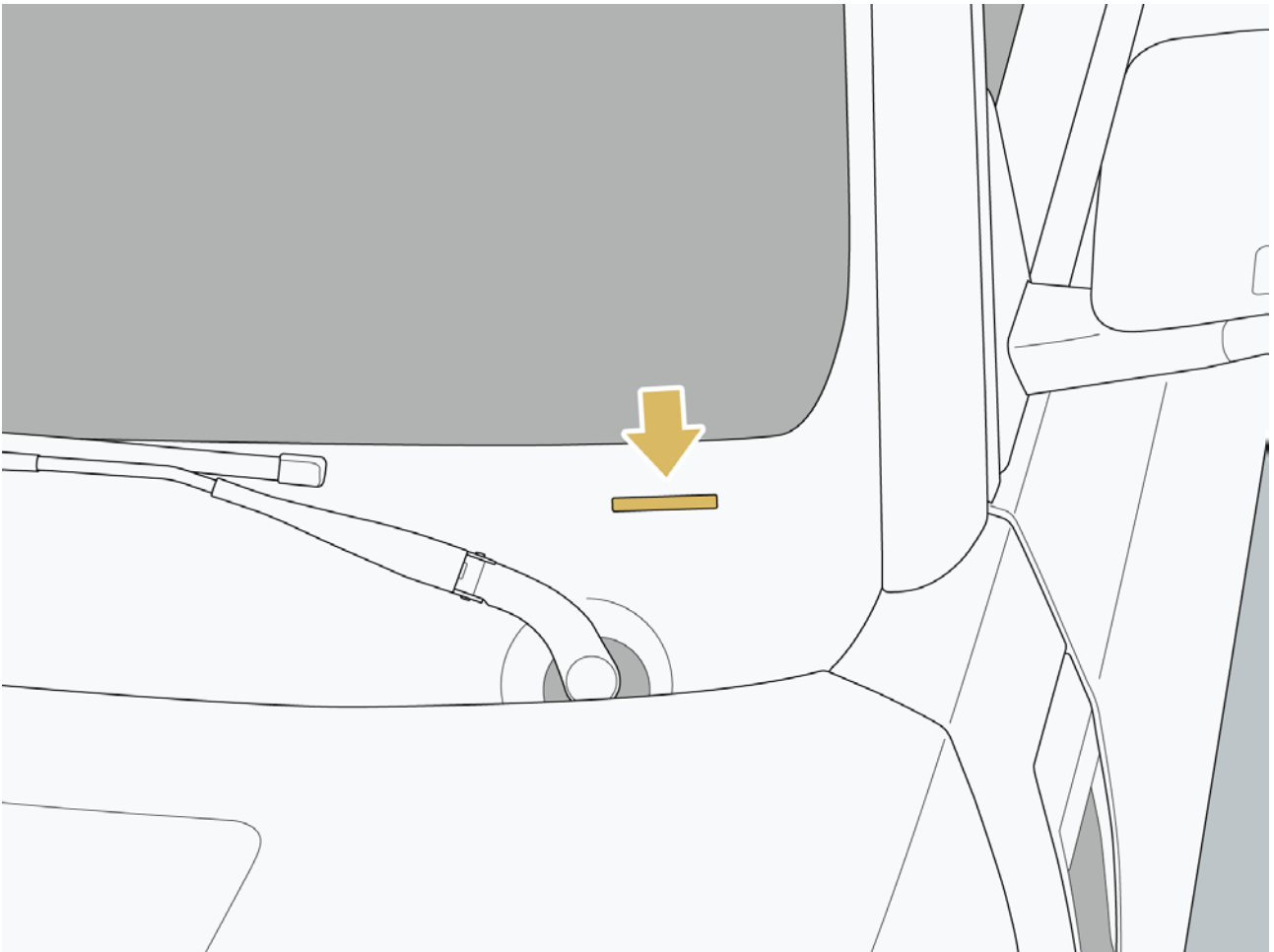

10 Vehicle specification

10.5.2 Range extender (engine) ID code

The range extender (engine) identification code is printed on the cylinder block.

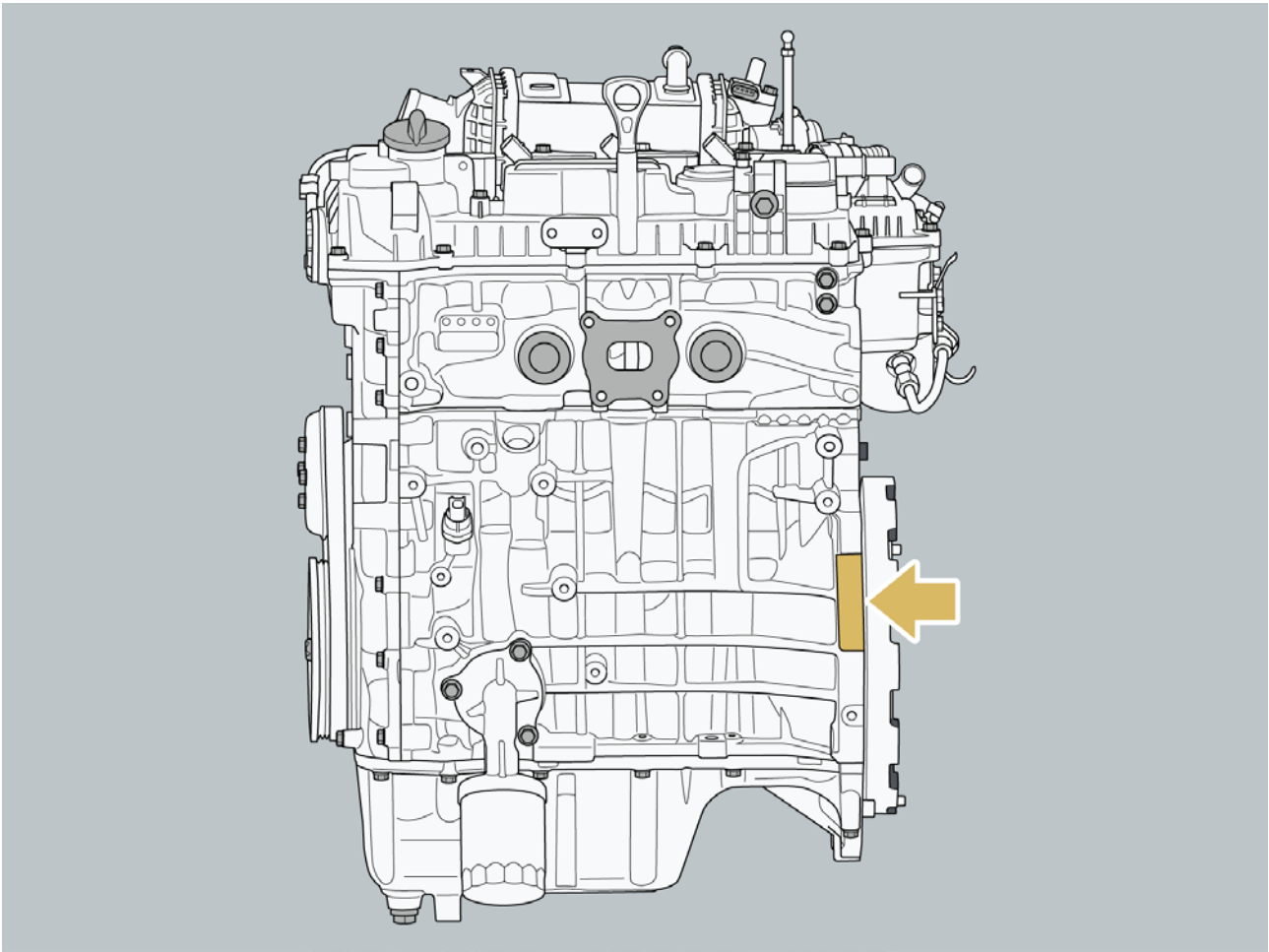

10.5.3 Drive motor identification code

I. Front drive motor

S/N	Item
1	Motor identification code
2	Motor stamping

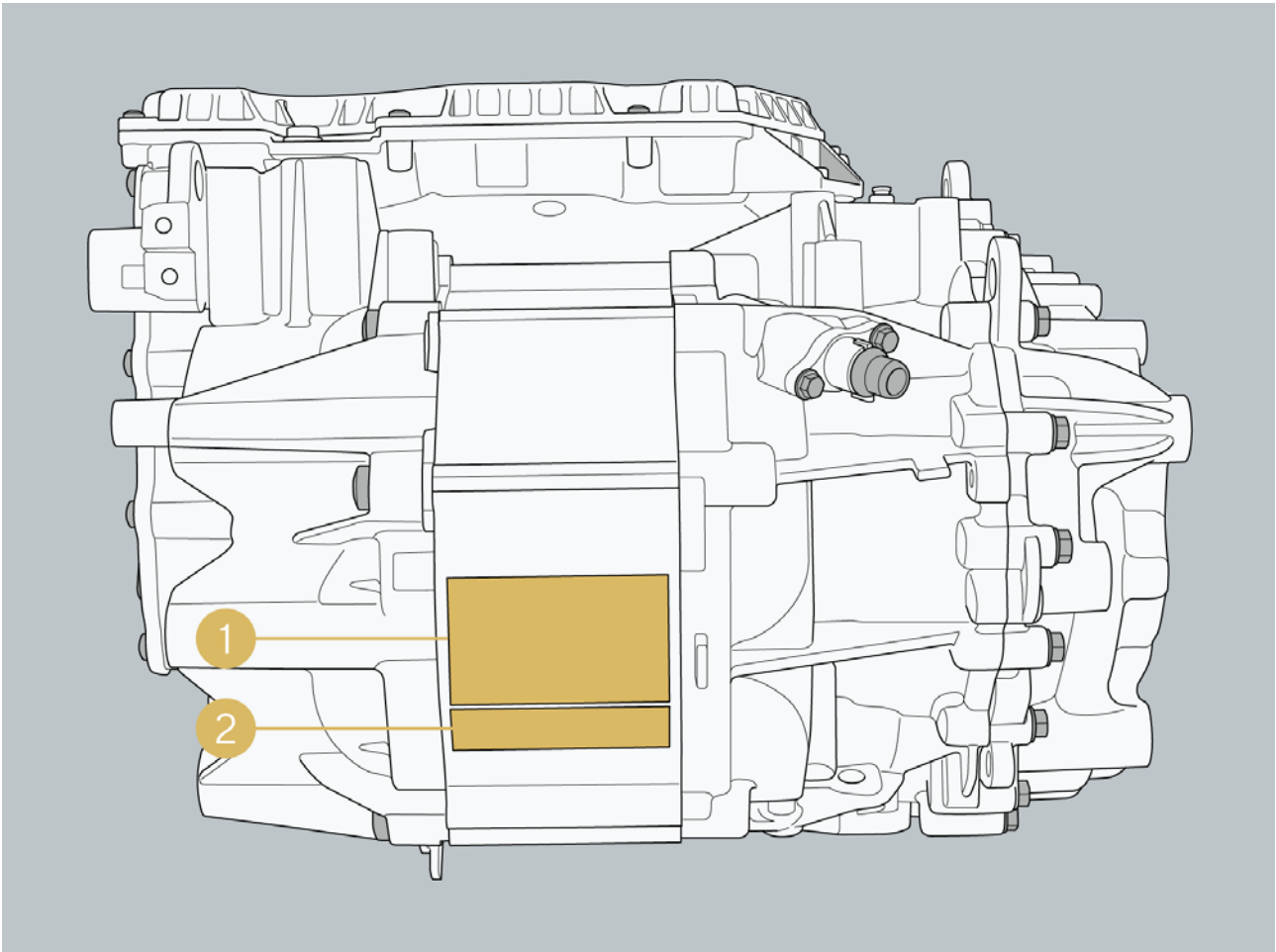

10 Vehicle specification

II. Rear drive motor

S/N	Item
1	Motor identification code
2	Motor stamping

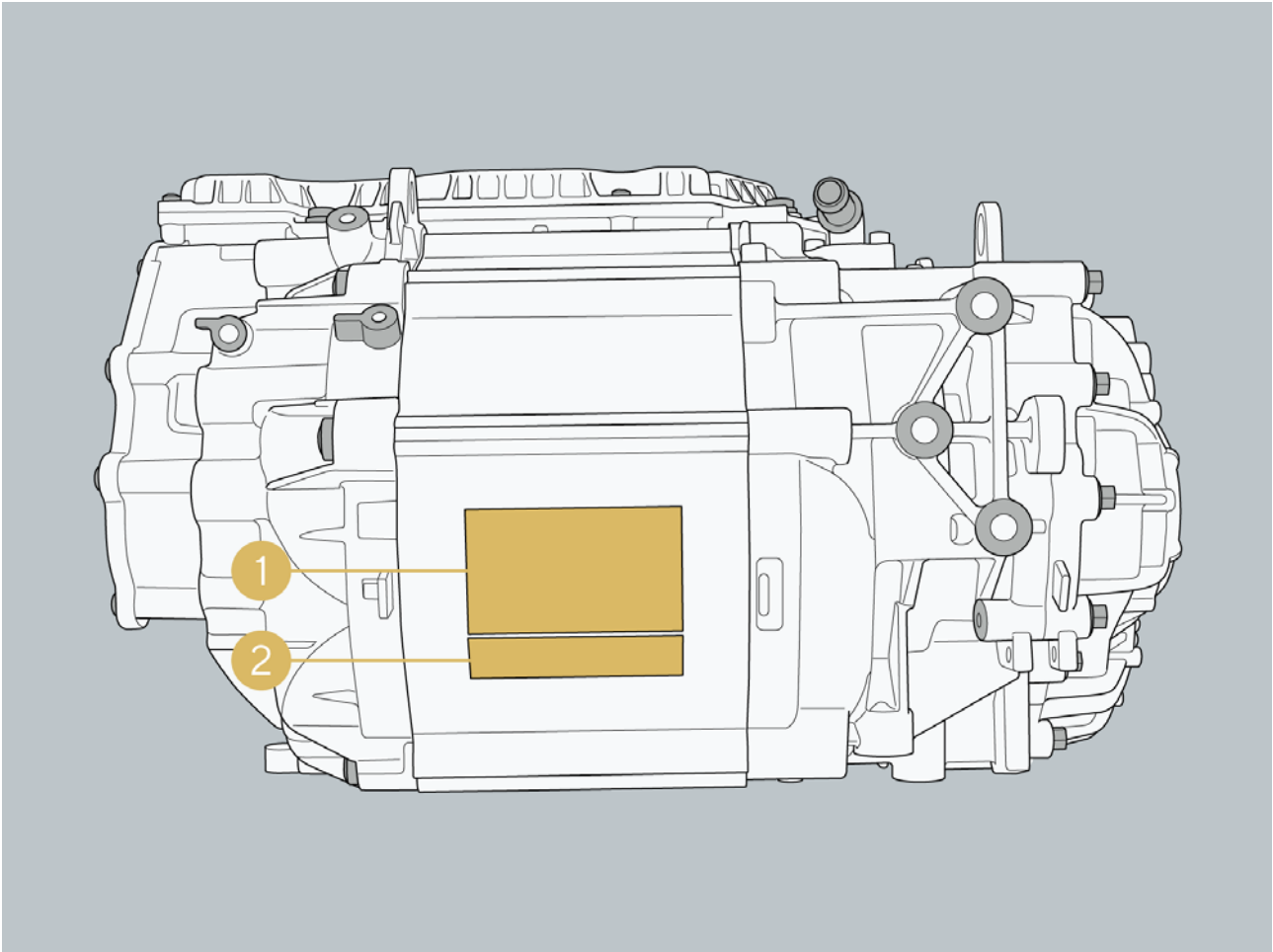

10.5.4 Microwave window

Microwave window

There is a microwave window on the windshield, which can be used to paste electronic label.

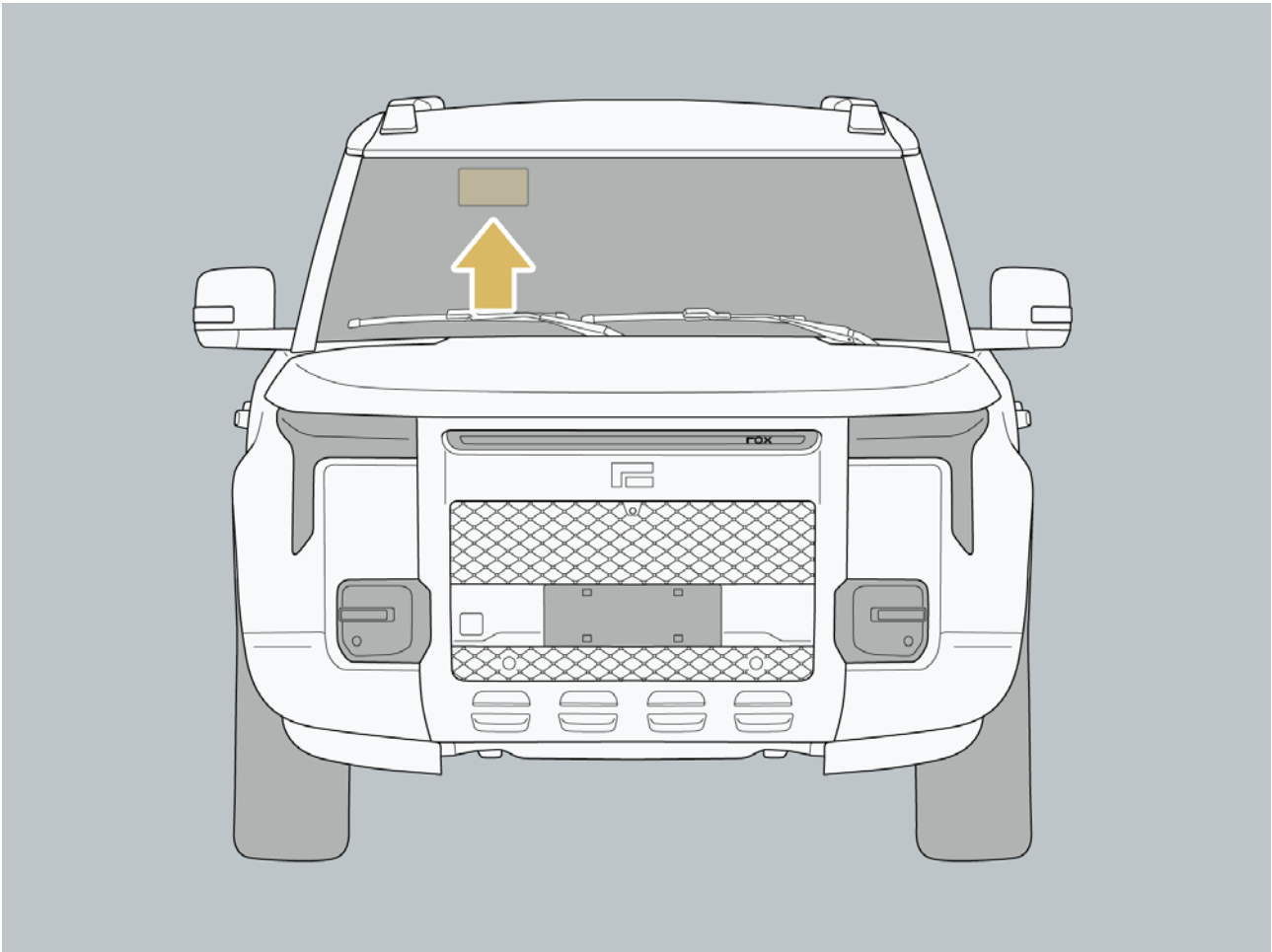

10 Vehicle specification

10.5.5 Ex-work nameplate

Ex-work nameplate

The ex-work nameplate is located at the lower end of the B-pillar on the passenger side, which is marked with the vehicle model, VIN and other information.

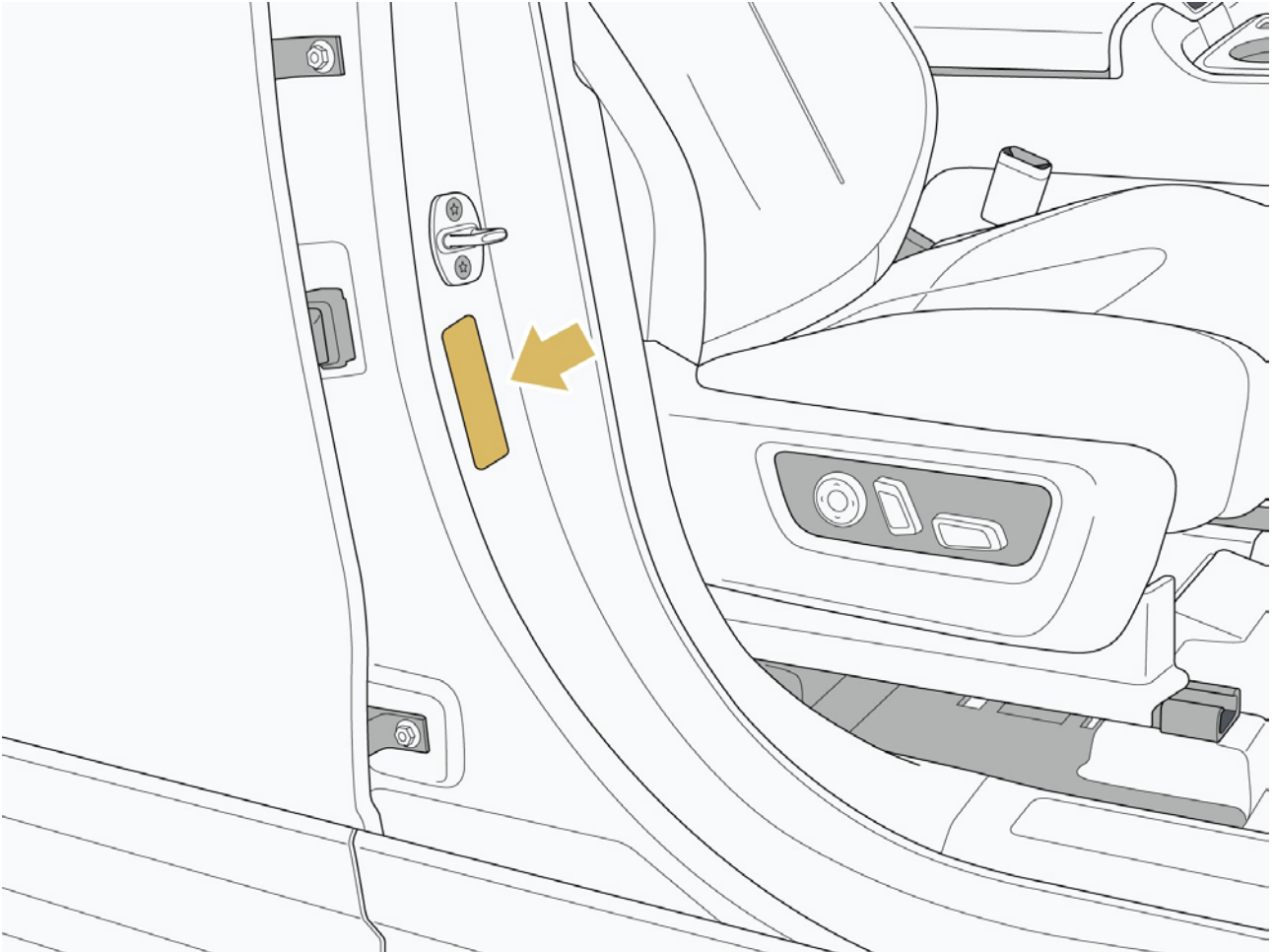

10.5.6 Diagnostic interface

The diagnostic interface is located on the left side of the instrument panel, above the brake pedal, which is used to read vehicle information.

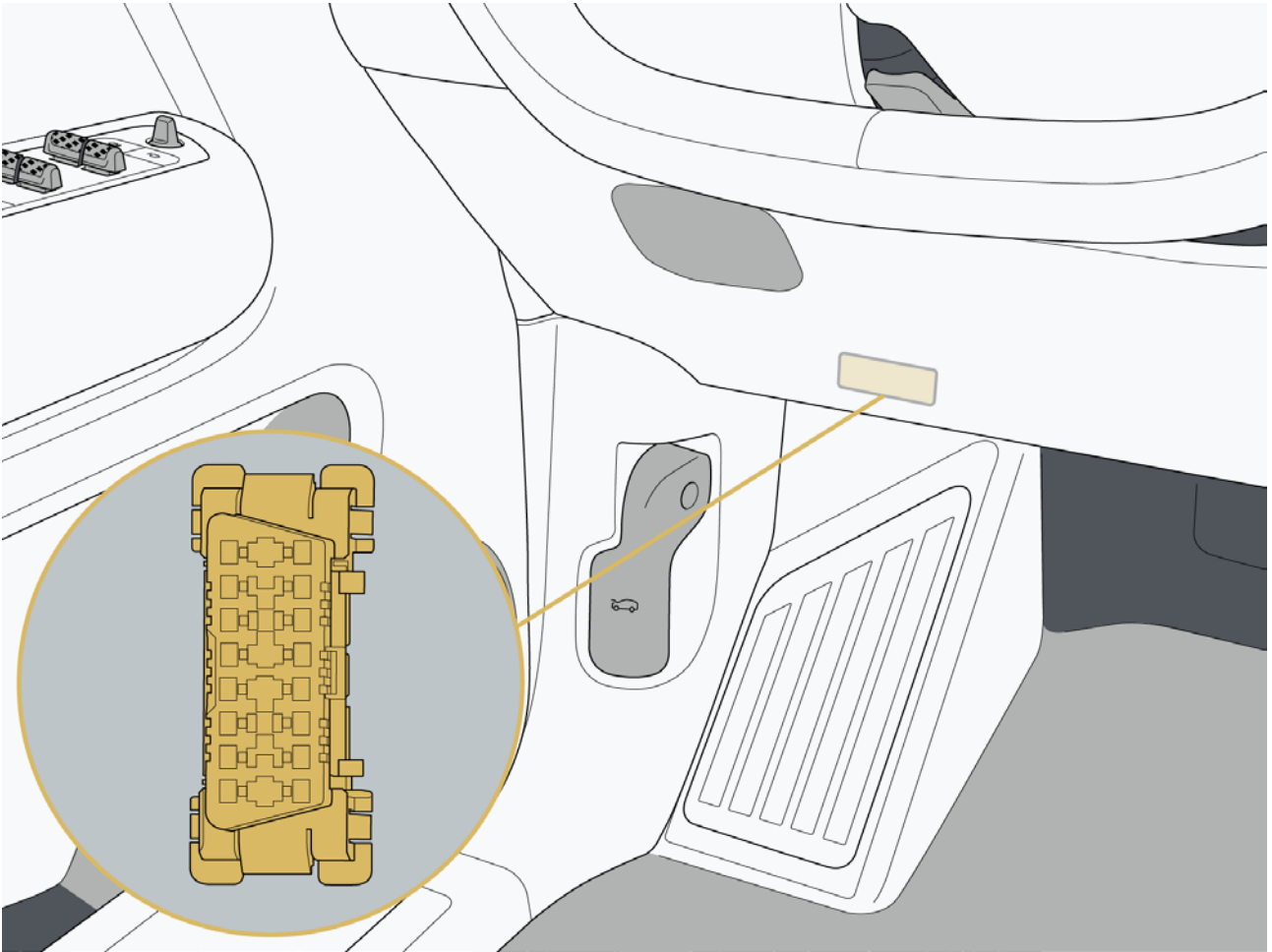

10 Vehicle specification

10.5.7 Warning and indication label

I. Engine compartment safety warning label

⚠ CAUTION تنبيهات ВНИМАНИЕ ⓘ		
	Refrigerant سائل تبريد Тип хладагента	R134a
	Charge level كمية التحميلة Заправка хладагента	(1100±25)g

11 Abbreviations and terminology

11.1 Abbreviations and terminology

11.1.1 Abbreviations and terminology

Abbreviat ion	Instructi on	Abbreviat ion	Instruction	Abbreviat ion	Instructi on	Abbreviat ion	Instructio n
A	Ampere	km	Kilometer	m	Meter	MΩ	Megohm
dB	Decibel	km/h	Kilometer/ hour	mA	Milliamp ere	N	Newton
ft	Foot	kPa	Kilopascal	mg	Milligra m	Nm	Newton•m eter
g	Gram	kW	Kilowatt	MHz	Megaher tz	No.	S/N
gal	Gallon	KΩ	Kiloohm	ml	Milliliter	rpm	Revolution s per minute
Hz	Hertz	lb	Pound	mm	Millimete r	V	Volt
in	Inch	lb-in	Pound-inch	mpg	Miles per gallon	W	Watt
kg	Kilogra m	lb-ft	Pound-foot	mph	Miles per hour	ya	Yard
kHz	Kilohertz	L	Liter	mV	Millivolt	min	Minute
s	Second	km	千米	°	Degree	°C	Celsius

11 Abbreviations and terminology

Abbreviation	Full English name	Chinese name	Abbreviation	Full English name	Chinese name
ABS	Anti-lock Brake System	防抱死制动系统	DOHC	Double Overhead Camshaft	顶置双凸轮轴
A/C	Air Conditioning	空调	DTC	Diagnostic Trouble Code	故障代码
AM/FM	Amplitude Modulation/ Frequency Modulation	调幅/调频	DVD	Digital Video Disk	DVD
ASR	Acceleration Skid Control System	加速防滑控制系统	EBD	Electric Brakeforce Distribution	电子制动力分配
AT	Auto Transmission	自动变速器	ECM	Engine Control Module	发动机控制模块
BCM	Body Control Module	Body control module	EDS	Electronic Differential System	电子差速锁
CD	Compact Disc	CD	EGR	Exhaust-Gas Recirculation	废弃再循环
CAN	Controller Area Network	控制器局域网	ESP	Electronic Stability Program	电子稳定程序
EOBD	Eruopean On Board Diagnostic	欧洲在线诊断	FWD	Front Wheel Drive	前轮驱动
ISO	International Standards Organization	国际标准化组织	LED	Light-Emitting Diode	发光二极管
MP3	MPEG Audio Layer 3	MP3	MT	Manual Transmission	手动变速器
GPS	Globe Positioning System	全球定位系统	HVAC	Heating Ventilation Air Conditioning	暖风、通风和空调

11 Abbreviations and terminology

Abbreviation	Full English name	Chinese name	Abbreviation	Full English name	Chinese name
OBD-II	On Board Diagnostic II	在线诊断 II	OEM	Original Equipment Manufacturer	原始设备制造商
PAM	Parking Aid Module	停车辅助模块	RWD	Rear Wheel Drive	后轮驱动
SAE	Society of Automotive Engineers	美国汽车工程师学会	SFI	Sequential Fuel Injection	顺序燃油喷射
SOHC	Single Overhead Camshaft	单顶置凸轮轴	SRS	Supplemental Restraint System	辅助安全系统
SUV	Sport Utility Vehicle	越野车	TDI	Turbo Direct Injection	涡轮增压直喷
TPMS	Tire Pressure Monitoring System	轮胎压力监控系统	4WD	Four Wheel Drive	4轮驱动
MS-CAN	Middle Speed Controller Area Network	Middle speed controller area network			



customerservice@roxmotor.com

Consultation methods